



Capture, extraction and filtration of pollutants and heat in commercial or collective kitchens.  
Single backed or double central.  
Single modules of length 1000, 1500, 2000, 2500 and 3000 mm.  
Without visor or with depth of 1000, 1250, 1500 or 1750 mm.  
Height of 400 mm and 500 mm.  
Constant hood height for a maximum capture volume.  
Self-supporting construction without visible attachment or sharp edges for cleaning without risk of injury.  
Side reinforcement, 15/10mm galvanized steel, height 50mm, integrated into the hood, ensuring the rigidity of the assembly.  
Setting the level from inside the hood and clip-in fastener caps.  
Braced at the sensor end for rigid joint between two modules providing a large air passage.

Visible faces austenitic stainless steel AISI 304 (1.4301) with a brushed finish SB.

- Central hoods assembled back to back using two hoods backed with partitions.
- Sides without obvious elements such as rivets and studs.
- Rear and upper surfaces in galvanized steel.
- Standard filter galvanized material, stainless steel frame M0397x472x25 mm.
- Stainless steel closure plate.
- Peripheral gutter.
- Drain with stainless steel - threaded plug Gas 1/2.

Packaging: Packaged on pallet in heat-shrink film.

#### **On request**

- Rear assembly plate without visible screws and top panel in stainless steel.
- Longer and special lengths available.
- Accessories (ring plate, balancing guillotine damper, waterproof light etc.).
- Motorised hoods, laundries, ovens, comfort, comfort 90/10, 30 to 60% induction, closed filter ceilings, modular ceilings etc.

---

#### **Specific applications**



Commercial  
and  
industrial  
kitchens

**TECHNICAL CHARACTERISTICS**

Model	Length (mm)	Weight (kg)				
		Without extension	Hood 1000	Hood 1250	Hood 1500	Hood 1750
MAXFIL <sup>2</sup> COMPACT PRO 500 LG 1000	1000	32	45	50	54	60
MAXFIL <sup>2</sup> COMPACT PRO 500 LG 1500	1500	41	58	64	69	76
MAXFIL <sup>2</sup> COMPACT PRO 500 LG 2000	2000	55	76	83	89	97
MAXFIL <sup>2</sup> COMPACT PRO 500 LG 2500	2500	64	89	98	105	114
MAXFIL <sup>2</sup> COMPACT PRO 500 LG 3000	3000	74	103	114	121	131

**DIMENSIONS (mm)**

Optional lights - Supplied undrilled

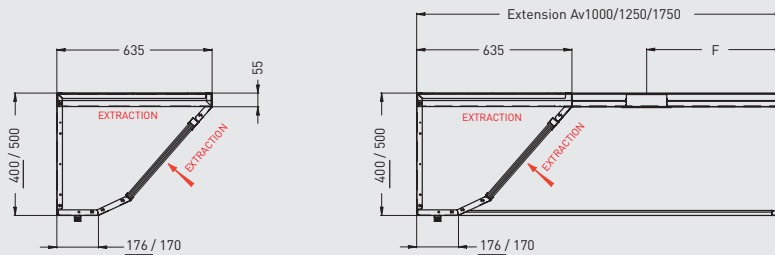

Underlined = size of 400 model  
 Normal = size of 500 model

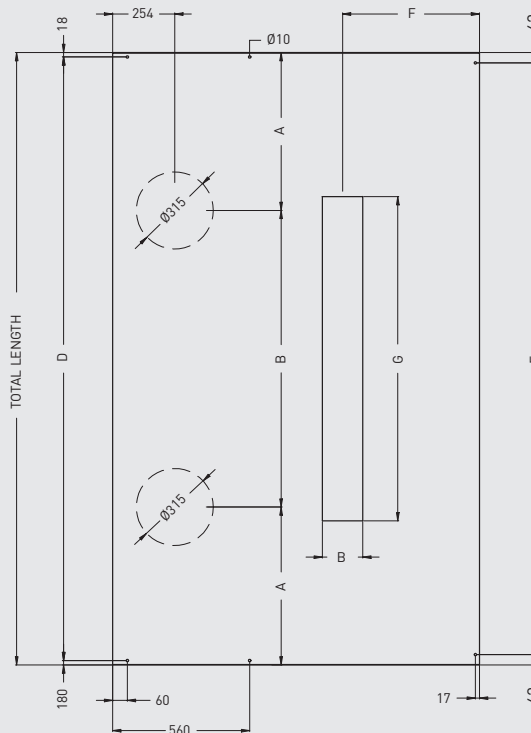

Unit	Total length*	Length of collection	N° of vents for extraction	N° of filters / sheets	A	B	D	E	Extended 1000		Extended 1250		Extended 1500	
									F	G	F	G	F	F
1000	1004	1000	1	2 / 0	502	-	968	920	185	695	310	695	810	695
1500	1504	1500	1	2 / 1	752	-	1468	1420	185	1325	310	1325	810	1325
2000	2004	2000	2	2 / 2	514	976	1968	1920	185	1325	310	1325	810	1325
2500	2504	2500	2	3 / 2	645,5	1213	2468	2420	185	1325	310	1325	810	1325
3000	3004	3000	2	3 / 3	645,5	1713	2968	2920	185	1325	310	1325	810	1325

\* Total length of assembled modules: 3504, 4004, 4504, 5004, 5504, 6004

**INSTALLATION**

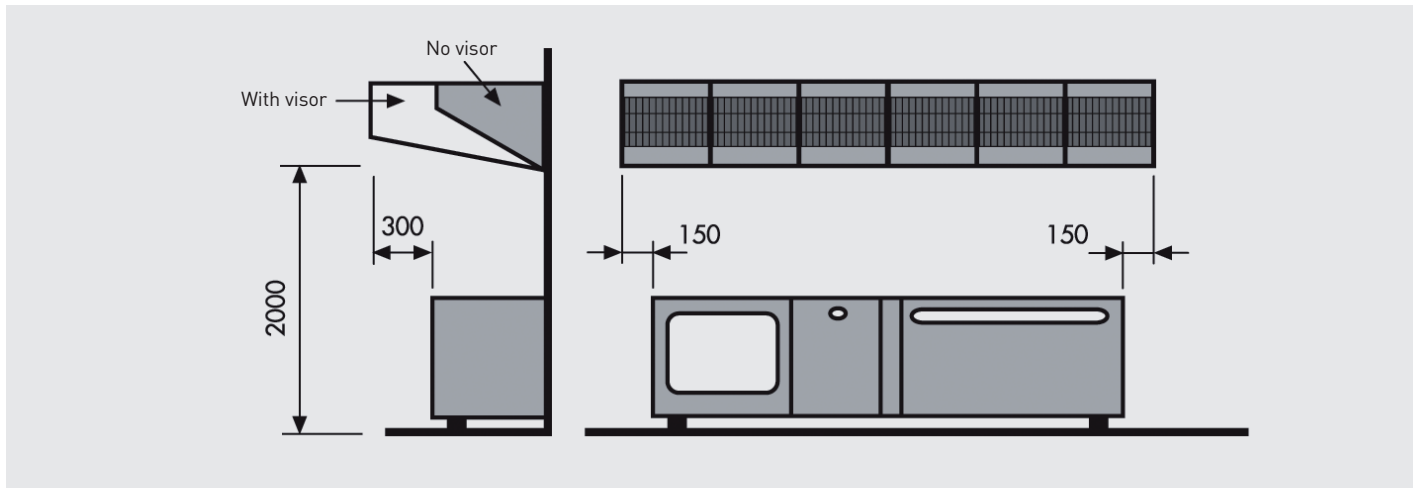

**ACCESSORIES**

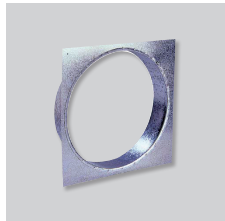

**Ferrule plate**

Connection Ø 160 to 500 mm.  
 Allows the connection to the circular extraction network or insertion into the hoods.  
 In galvanized steel as standard.  
 Can be supplied factory installed or as an accessory.

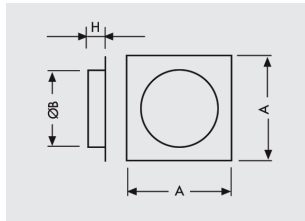

Model	ØB	A	H
FERRULE 160	160	195	40
FERRULE 200	200	235	40
FERRULE 250	250	290	60
FERRULE 315	315	350	70
FERRULE 355	355	390	80
FERRULE 400	400	440	80
FERRULE 500	500	564	80



**Guillotine damper**

Allows setting the balance of extraction flows.  
 With or without a ferrule plate (not necessary when using manifold).  
 In galvanized steel as standard.  
 Can be supplied factory installed or as an accessory.



**Waterproof lighting units**

IP 657 - Temp. +40° C.  
 2 x 18 W l 647 mm for 1000 mm unit.  
 1 x 36 W l 1257 mm for 1500 mm unit.  
 Delivered unassembled.

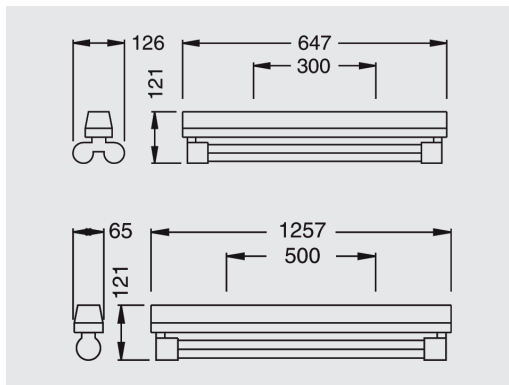

**ACCESSORIES**



**Waterproof recessed lighting with armored glass protection**  
 IP-55 easy opening for replacement of tubes.  
 1 x 18 W l 695 mm for 1000 mm unit.  
 1 x 36 W l 1325 mm for 1500 mm unit and larger.  
 2 x 36 W l 1325 mm for 1500 mm unit and larger.  
 Comes with a 1.50 m connection cable.

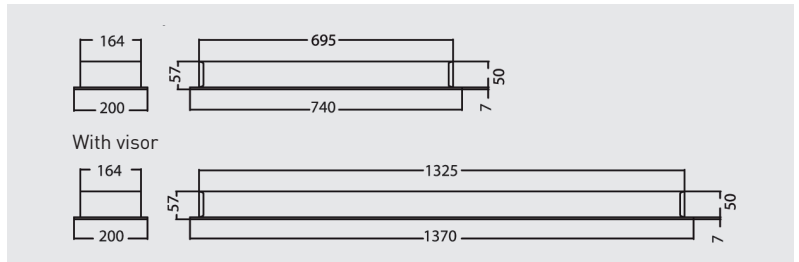

**Stainless steel choke filter**  
 Stainless steel inertial filter  
 H 397 x L 472 x Th. 25 mm.  
 With handles.

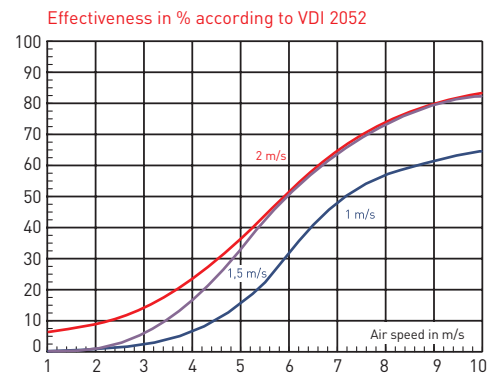
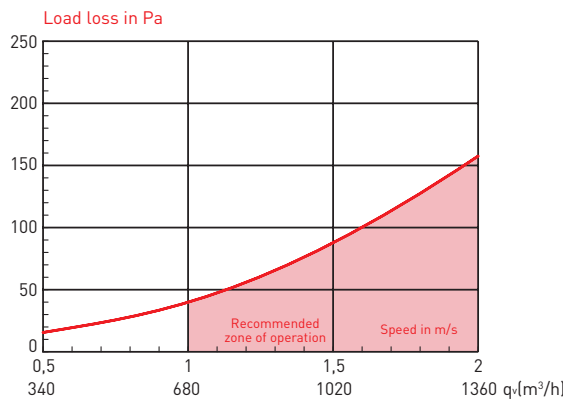

**Galvanised media filter - with stainless steel frame or all stainless steel**  
 Filter with stainless steel frame H 397 x L 472 x Th. 25 mm.  
 6 layers with 2 corrugated and one expanded metal.  
 With handles.

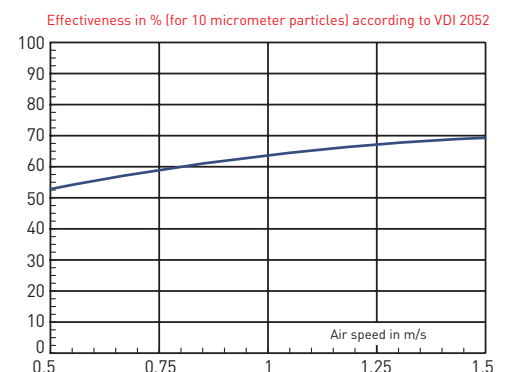
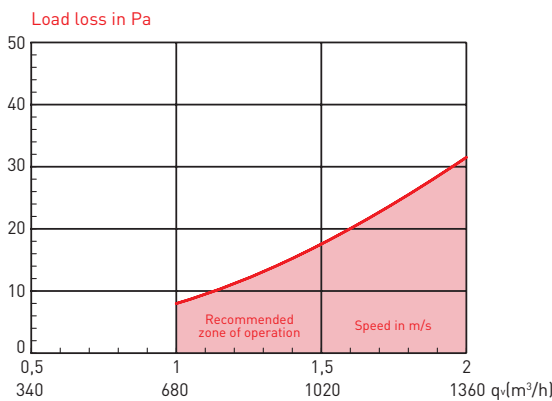

**Stainless steel closure plate.**  
 Dimensions H 397 x L 472 x Th. 25 mm.  
 Used to replace the filters.  
 Used to work with the filters in their optimal ranges and to balance the flows.

**ACCESSORIES**



**Combination filter, high efficiency 95%**  
 Stainless steel filter frame H 397 x L 472 x Th.45 mm to fit in 25 mm rail.  
 Consisting of: 1 Adjustable stainless steel filter + 1 5-layer (2-corrugated) galvanised filter.  
 With handles.

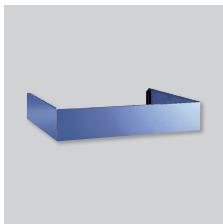
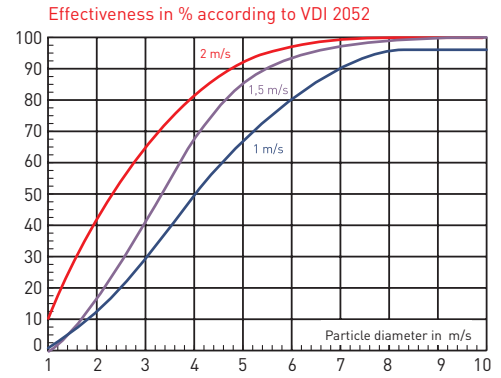
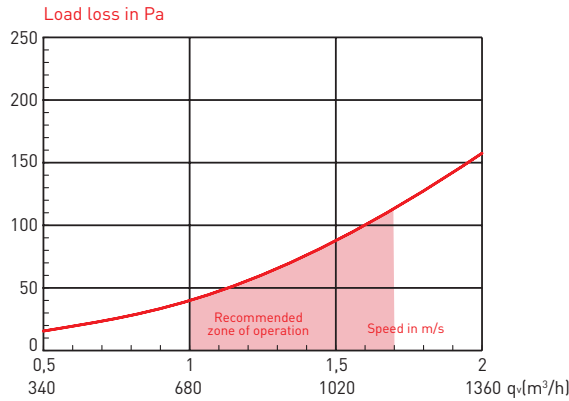

**Top panelling**  
 Stainless steel panels to cover the gap between the hood and the ceiling.

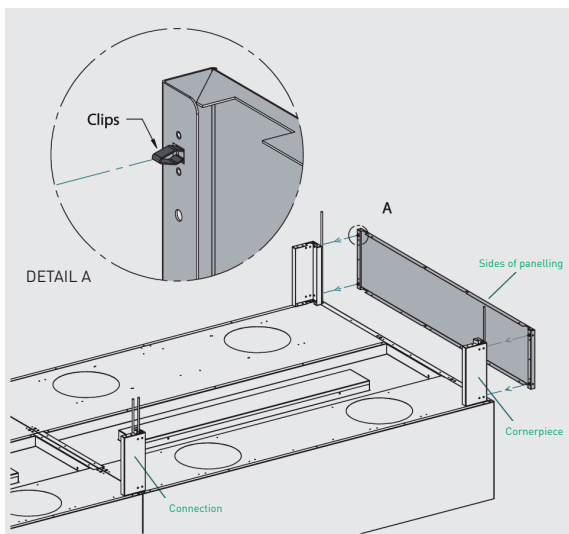

**Self-supporting system**  
 Self-supporting system: no visible screws or rivets, consisting of removable panels fixed on reinforced gussets positioned in the corners and panel joints. Allows the plate to hold the hood without additional fixation. Available in standard height 200 to 900 mm.

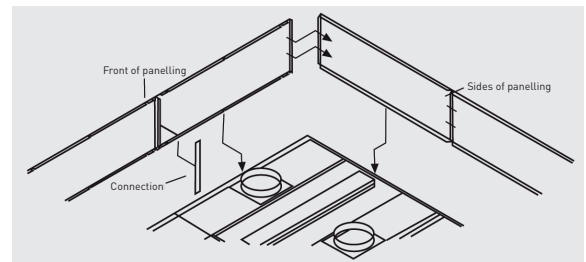

**Fastening system**  
 Fastening system: no visible screws or rivets, composed of panels fastened together at the top edge of the hood. Requires access to the fastening points by the top plate. Available in standard height 200 to 500 mm.

**Extraction manifolds**  
 Galvanized steel

