



CAD COMPACT ECOWATT





INDEX

1. INTRODUCTION.....	3
2. SAFETY REGULATIONS AND “CE” MARKING.....	3
3. GENERAL INSTRUCTIONS.....	3
4. UNIT LABELLING.....	3
5. HANDLING.....	4
6. INSTALLATION.....	4
6.1. INTRODUCTION.....	4
6.1.1. Outdoor installation.....	5
6.2. Dimensions and free space for maintenance.....	6
6.2.1. Dimensions.....	6
6.2.2. Free space for maintenance.....	8
6.3. Mounting process of an additional supply filter.....	8
6.4. Range specifications.....	9
6.5. Connections.....	9
6.5.1. Connection with air duct.....	9
6.5.2. Condensate drainage.....	9
6.6. Electrical connection.....	10
6.6.1. Wiring diagram.....	10
6.6.2. Fan operation without speed regulation. Operation at maximum speed.....	11
6.6.3. Connecting electrical accessories.....	11
6.6.3.1. VAV control (Variable airflow), manual adjustment.....	12
6.6.3.1.1. Manual adjustment by REB-ECOWATT (accessory).....	12
6.6.3.2. VAV Control (variable airflow), with CO ₂ sensor or similar.....	12
6.6.3.3. CAV control (constant airflow).....	13
6.6.3.4. COP Control (constant pressure).....	14
6.6.3.5. Pressure switch connection.....	15
6.7. Reverse outdoor air / indoor air side.....	16
7. INSPECTION, MAINTENANCE AND CLEANING.....	17
7.1. Filters replacement.....	17
7.2. Additional filter installation.....	18
7.3. Heat exchanger.....	18
7.4. Fans.....	18
7.5. Condensation drainpipe.....	19
8. OPERATION ANOMALIES.....	19
8.1. General anomalies.....	19

1. INTRODUCTION

Thank you for purchasing this appliance. It has been manufactured in full compliance with applicable safety regulations and **EU** standards.

Please read this instruction book carefully, as it contains important information for your safety during the installation, use and maintenance of this product.

Keep it at hand for future reference.

Please check that the appliance is in perfect condition when you unpack it, as all factory defects are covered by the **S&P** guarantee.

2. SAFETY REGULATIONS AND “CE” MARKING

S&P technicians are firmly committed to research and development of ever more efficient products and in compliance with current safety regulations.

The instructions and recommendations given below reflect current regulations, principally regarding safety, and therefore are based on compliance with general regulations. Therefore, we recommend all people exposed to hazards to strictly follow the safety regulations in force in your country. **S&P** will not be held liable for any possible harm or damage caused by non-compliance with the safety regulations, as well as caused by modifying the product.

The **CE** mark and the corresponding declaration of conformity are proof of the product’s conformity with current EU regulations.

3. GENERAL INSTRUCTIONS

A hazard analysis of the product has been carried out as provided in the Machine Directive. This manual contains information for all personnel exposed to these hazards, with the aim of preventing possible harm or damage due to faulty handling or maintenance.

All maintenance operations (ordinary and extraordinary) must be carried out with the machine switched off and the electrical power supply disconnected.

To avoid a possible accidental start up, place a warning notice on the electrical control panel with the following text:

“Attention: control disconnected for maintenance operations”

Before connecting the power supply cable to the terminal strip, make sure the mains voltage corresponds to the voltage indicated on the specifications plate of the unit.

Regularly check the product labels. If, due to the passing of time, they are no longer legible, they must be replaced.

4. UNIT LABELLING

The machine may come with several pictograms that must not be removed. These signs are divided into:

- **Prohibition signs:** Do not repair or adjust when in operation.
- **Danger signs:** Warning of the presence of live elements inside the container bearing the sign.
- **Identification signs:** CE card, indicating product information and manufacturer’s address. The **CE** mark indicates the product’s conformity with **EEC** standards.



Danger signs



Prohibition signs

5. HANDLING

The CAD-COMPACT ECOWATT units are delivered fixed with screws to the pallets. The handling machines will be adapted to the load and the lifting conditions. In all cases, the lifting will be done at the device's base. The centre of gravity is located at the centre of the unit. The device must be carefully manipulated only in the horizontal position.

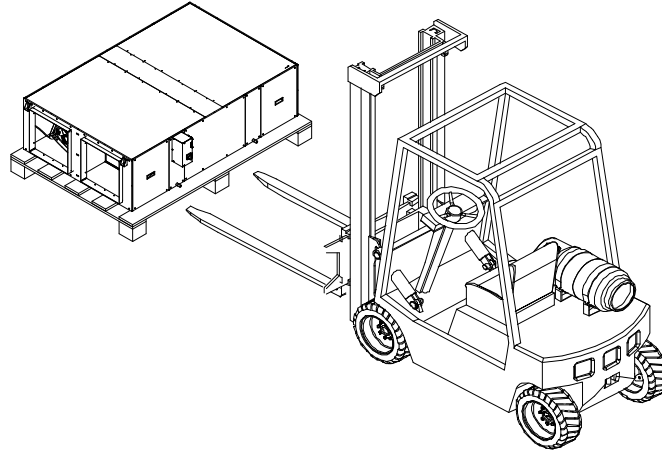

6. INSTALLATION

6.1. INTRODUCTION

All models are designed to be installed hanging from the ceiling or located behind a false ceiling. When installing the unit, it is necessary to distribute the unit weight between the 4 supports existing in the units. Using studded rods ($\varnothing 8$ mm), it can be secured to the ceiling and levelled:

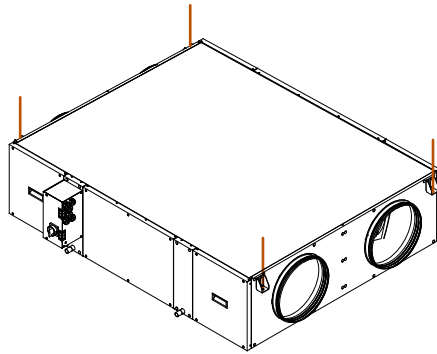

Check the distances between supports in the diagrams of the section: "Dimensions and free dimensions for maintenance".

The installer must make sure that the ceiling structure and the securing elements can bear the weight of the device, taking into account that it is a dynamic load.

To prevent the transmission of vibrations from the unit to the rest of the installation, it is necessary that the installer use specific isolation elements, as well as flexible couplings between the water connections and the pipelines.

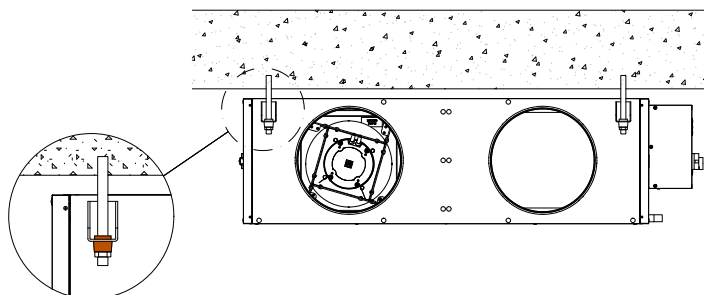

Model	Total weight of unit (kg)	Anti vibration kit support (Composed of 4 pcs.)
CAD COMPACT 500	70	KIT AM CAD-COMPACT
CAD COMPACT 900	86	KIT AM CAD-COMPACT
CAD COMPACT 1300	137	KIT AM CAD-COMPACT
CAD COMPACT 1800	145	KIT AM CAD-COMPACT
CAD COMPACT 2500	235	KIT AM CAD-COMPACT
CAD COMPACT 3200	235	KIT AM CAD-COMPACT
CAD COMPACT 4500	336	KIT AM CAD-COMPACT

6.1.1. Outdoor installation

The CAD-COMPACT ECOWATT range is advisable to be mounted indoors. Outdoor mounting is limited to areas with less extreme climates. When it is installed outdoors, it is preferable to place the unit under a cover which offers enough protection to prevent rain falling directly to the unit, or install the corresponding rain canopy (accessory). If installed on the ground, sufficient space must be guaranteed under the unit so that it is possible to install the corresponding siphons in the condensate outlets of the unit.

There is a Kit composed of 4 feet, which facilitates the assembly on floor of these versions: KIT FEET CAD-COMPACT.

Both in the case that the KIT FEET CAD-COMPACT is used, and if the unit is based on vibrators or supports made on site, it is essential that the heat exchanger's support is guaranteed on 4 existing support points (4 pcs. in the corners of the unit).

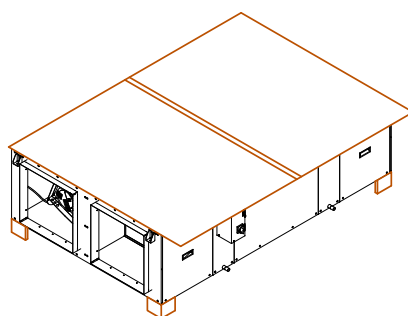

Detail of a CAD-COMPACT with the corresponding canopy and Kit feet

List of necessary accessories needed for outdoor mounting:

Model	Pies soporte	Tejadillo
CAD COMPACT 500	KIT PIES CAD COMPACT	TPP-CAD COMPACT 500
CAD COMPACT 900	KIT PIES CAD COMPACT	TPP-CAD COMPACT 900
CAD COMPACT 1300	KIT PIES CAD COMPACT	TPP-CAD COMPACT 1300
CAD COMPACT 1800	KIT PIES CAD COMPACT	TPP-CAD COMPACT 1800
CAD COMPACT 2500	KIT PIES CAD COMPACT	TPP-CAD COMPACT 2500
CAD COMPACT 3200	KIT PIES CAD COMPACT	TPP-CAD COMPACT 3200
CAD COMPACT 4500	KIT PIES CAD COMPACT	TPP-CAD COMPACT 4500

In addition to the roof and Kit feet, it is necessary to equip the duct network with rain hoods or air intakes equipped with anti-bird mesh to prevent the entry of animals or objects into the interior of the heat recovery unit.

Avoid condensations in electrical cabinet

In units located in outdoor installation where the heat recovery units stop during the night or during long intervals of time, it is necessary to:

- a) Install isolation dampers in air inlet and air outlet.
- b) Add anticondensation devices in the electrical cabinet as: cabinet heating elements that prevent condensation formation on cabinet surfaces and electronic components.

6.2. DIMENSIONS AND FREE SPACE FOR MAINTENANCE

6.2.1. Dimensions

a) CAD-COMPACT 500 to 1800 models

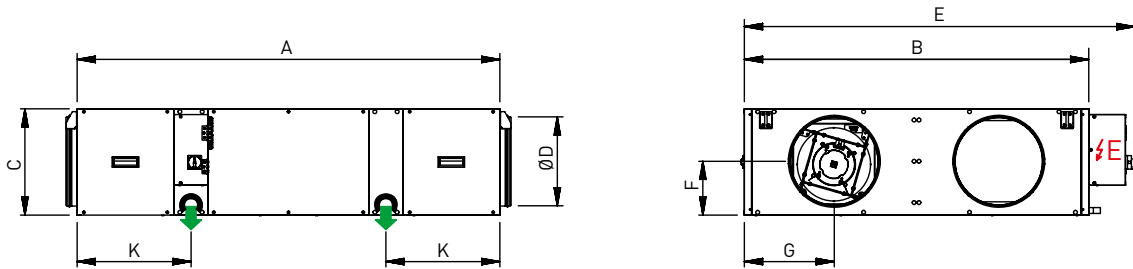

TOP VIEW

BY DEFAULT (FACTORY SUPPLY)

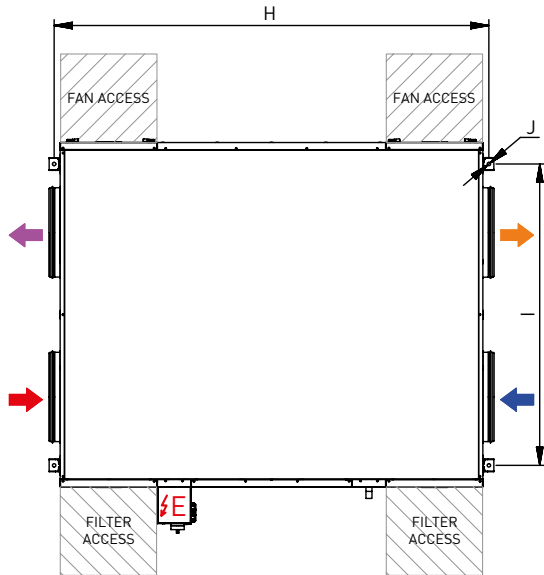

CONFIGURATION RESULT OF SIMPLE MODIFICATION ON SITE

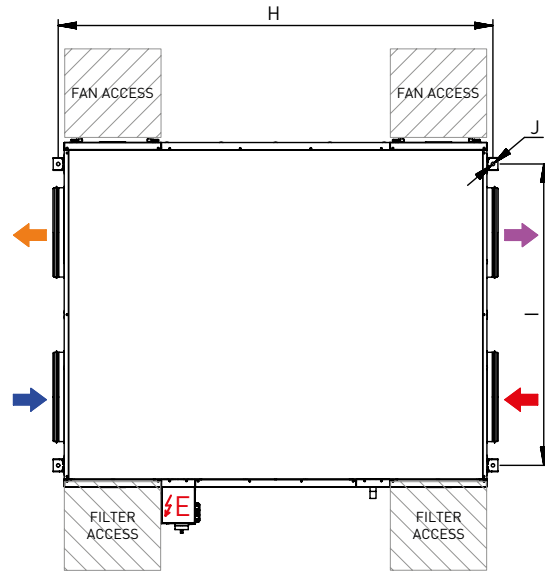

- ELECTRICAL CABINET
- OUTDOOR AIR INTAKE
- SUPPLY NEW AIR
- EXTRACT INDOOR AIR
- EXHAUST INDOOR AIR
- CONDENSATE OUTLET 1/2"

Model	A	B	C	D	E	F	G	H	I	J	K
CAD-COMPACT 500	1120	698	289	200	862	147	188	1163	546	12	256
CAD-COMPACT 900	1345	843	376	315	1007	190	225	1388	691	12	328
CAD-COMPACT 1300	1495	1218	376	315	1382	190	318	1538	1066	12	403
CAD-COMPACT 1800	1580	1083	453	355	1247	228	285	1623	931	12	393

b) CAD-COMPACT 2500 to CAD-COMPACT 4500 models

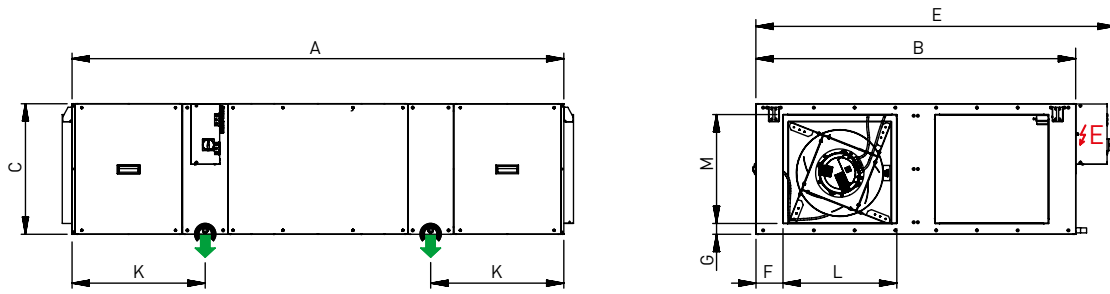

TOP VIEW

BY DEFAULT (FACTORY SUPPLY)

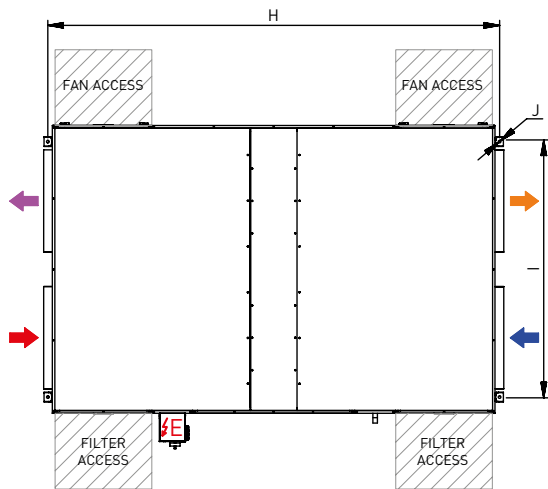

CONFIGURATION RESULT OF SIMPLE MODIFICATION ON SITE

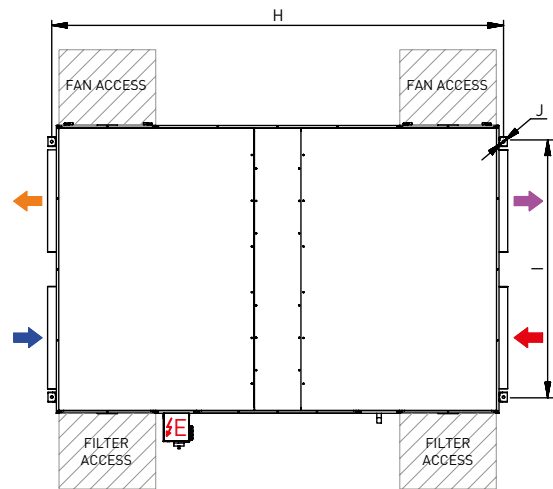

- ELECTRICAL CABINET
- OUTDOOR AIR INTAKE
- SUPPLY NEW AIR
- EXTRACT INDOOR AIR
- EXHAUST INDOOR AIR
- CONDENSATE OUTLET 1/2"

Model	A	B	C	D	E	F	G	H	I	J	K	L	M
CAD-COMPACT 2500	1845	1495	453	-	1670	127	41	1888	1343	17	385	570	375
CAD-COMPACT 3200	2038	1325	541	-	1489	113	43	2081	1176	12	552	470	450
CAD-COMPACT 4500	2207	1993	598	-	2156	165	79	2250	1844	12	594	700	440

6.2.2. Free space for maintenance

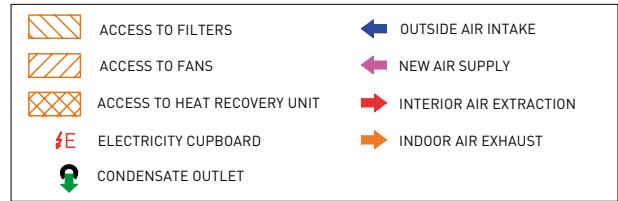
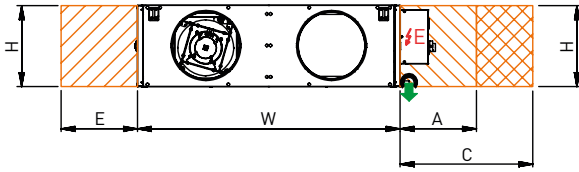

TOP VIEW
BY DEFAULT (FACTORY SUPPLY)

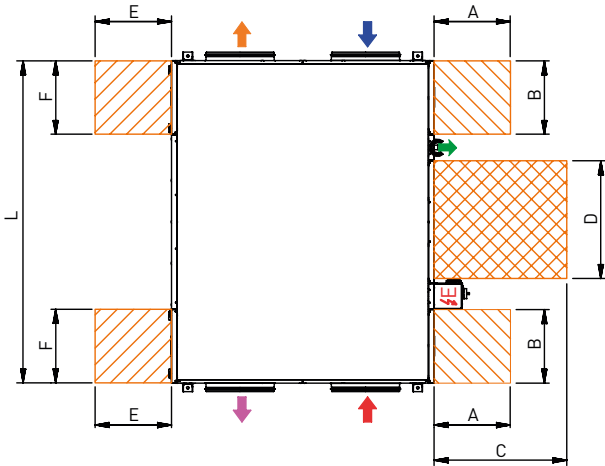

TOP VIEW
CONFIGURATION RESULT OF SIMPLE MODIFICATION ON SITE

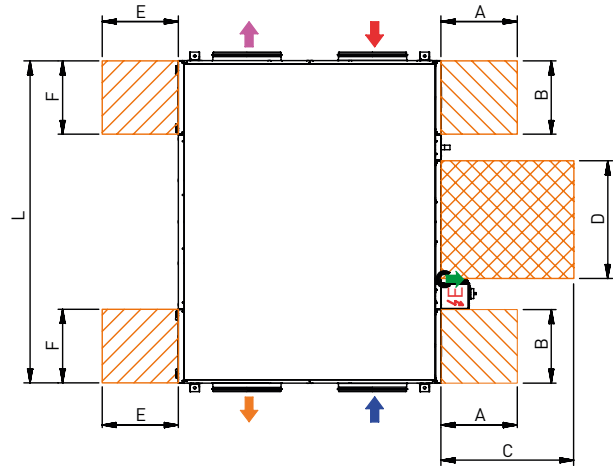

Model	Unit			Filters			Heat exchanger			Fans		
	L	W	H	H	A	B	H	C	D	H	E	F
CAD-COMPACT 500	1120	698	289	289	295	300	289	500* / 550**	487	289	500	300
CAD-COMPACT 900	1345	843	376	376	365	300	376	500* / 680**	570	376	500	300
CAD-COMPACT 1300	1495	1218	376	376	555	350	376	500* / 1020**	570	376	580	350
CAD-COMPACT 1800	1580	1083	453	453	490	350	453	500* / 820**	650	453	500	350
CAD-COMPACT 2500	1845	1495	453	453	360	350	453	500* / 650**	650	453	550	350
CAD-COMPACT 3200	2038	1325	541	541	280	300	541	500* / 550**	745	541	550	300
CAD-COMPACT 4500	2207	1993	598	598	440	450	598	500* / 820**	800	598	800	450

* On-site inspection or cleaning (recommended)

** Exchanger disassembly dimension (not recommended)

6.3. MOUNTING PROCESS OF AN ADDITIONAL SUPPLY FILTER

The heat recovery unit is supplied with the filters already installed. F7 (ePM1 70%) in exhaust air and M5 (ePM10 50%) in supply air. In addition, it is possible to mount a second filter in the unit (accessory) (for more information see section "Replacing filters").

6.4. RANGE SPECIFICATIONS

Model	Diameter connections air (mm)	Nominal airflow 150Pa** (m ³ /h)	Efficiency heat recovery unit* (%)	Electrical power supply	Maximum absorbed power** (kW)	Maximum current** (A)	Weight (kg)
CAD-COMPACT 500	200	440	82,2	1/230V, 50-60Hz	0,31	2,0	70
CAD-COMPACT 900	315	790	82,0	1/230V, 50-60Hz	0,45	3,2	91
CAD-COMPACT 1300	315	1.120	82,3	1/230V, 50-60Hz	0,88	4,0	120
CAD-COMPACT 1800	355	1.670	82,7	1/230V, 50-60Hz	1,02	4,2	150
CAD-COMPACT 2500	570x375	2.180	83,5	1/230V, 50-60Hz	0,92	3,9	200
CAD-COMPACT 3200	470x450	3.000	83,7	1/230V, 50-60Hz	2,00	8,7	235
CAD-COMPACT 4500	700x440	4.165	84,6	3/400V, 50-60Hz	2,76	4,2	336

* Wet efficiency referred to nominal airflow, external conditions [-5°C 80% RH] and interior [20°C / 50% RH].

** Sum of both fans.

6.5. CONNECTIONS

6.5.1. Connection with air duct

The fans are always blowing out with regard to the machine. Before making the connection of air lines, verify existing identification labels in each mouth of the heat recovery units.

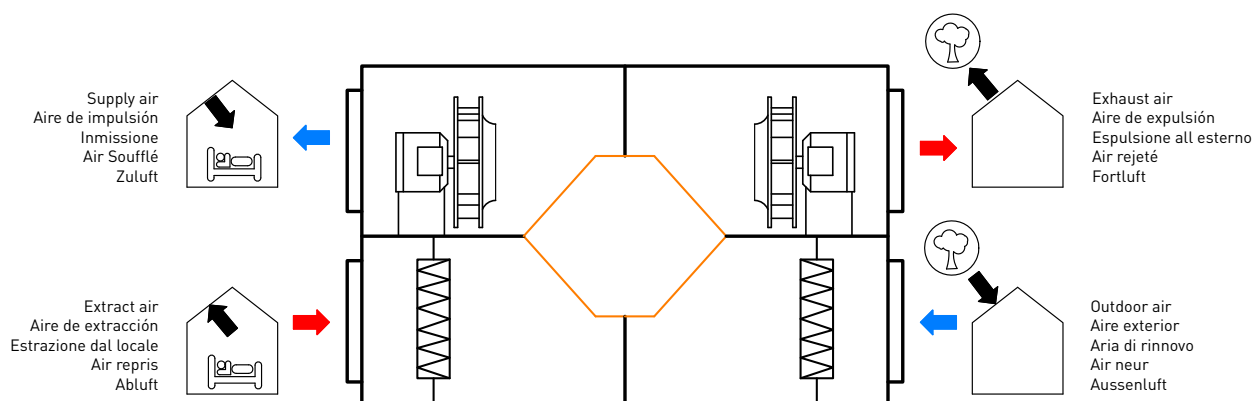

6.5.2. Condensate drainage

The units are supplied with 2 drains (one for each circuit). For added security it has to connect two drains to the drain pipe of the building. Drain tips are 1/2 "GM threaded.

Drainage system

- To ensure the removal of draining condensate from the tray a siphon must be installed with pressure head difference in mmWG greater than the pressure provided by the fan.
- The horizontal sections should have a minimum slope of 2%.

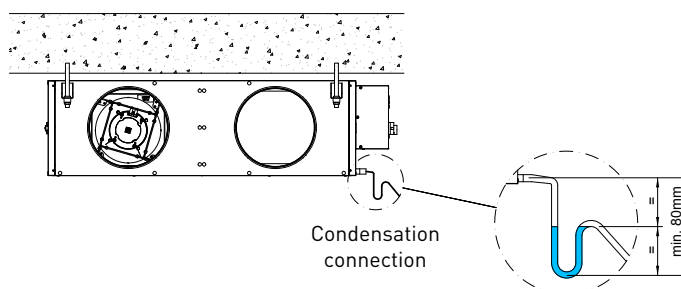

The siphon should always be full of water. Check its level periodically, refilling it if necessary. An empty siphon can cause the condensate tray to overflow and water leak through the equipment enclosure.

6.6. ELECTRICAL CONNECTION

The CAD-COMPACT ECOWATT range are supplied without a complete operating control integrated in the unit. The electrical components included in the unit (fans, by-pass servomotor, filter pressure switches and temperature probes) are supplied wired in an electrical cabinet located in one side of the unit. To access the electrical terminal block and conveniently make the electrical connection of the accessories it is advisable to remove the connection board, follow the following sequence:

1. Loosen the 5 screws that are distributed by the cover of the electrical cabinet (Fig. 1)
2. Open the cover and pull the metal plate on which the electrical terminals are located until it is outside the cabinet (Fig. 2).
3. The electrical cabinet has a PG connector for the electrical power cable. Further of this, in a bag that is supplied inside the unit, there are 3 more connectors that can be used to route the control wiring to the control accessories or the control panel of the building. Pass the necessary wiring through the connectors.
4. Make the electrical connection to the control board and put it back inside the electrical cabinet, making it slide through the existing guides (Fig. 3).

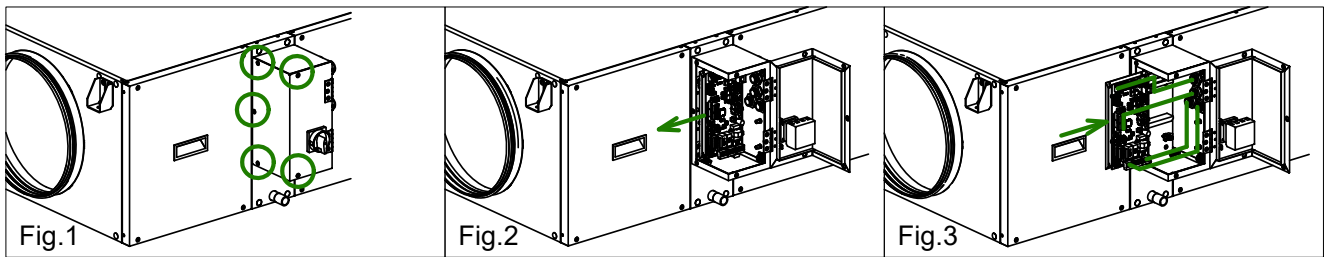

It is recommended to reduce the wiring lengths of the control maneuvers in order to reduce possible effects of the environment on the control signals.

To avoid interference that may affect the operation of the unit, it is recommended that the wiring be routed away from other electrical power lines, motors, refrigeration compressors, frequency inverters or the like.

This equipment complies with the Electromagnetic Compatibility Regulations that are applicable to them.

The use of shielded cables is recommended, although in environments with a high level of electromagnetic disturbances, it may become necessary to shield the wiring using a metal tube.

6.6.1. Wiring diagram

CAD-COMPACT models 500 to 3200 have plug-fans with EC motors 230V supply voltage, while the CAD-COMPACT 4500 model have fans with a three-phase motor.

The electrical wiring consists of two phases: the power supply of the fans and the control wire.

Fans power wiring

The two fans are wired to the switch located on the lid of the electrical cabinet. To power the fans, wire the power line to the terminals of the switch.

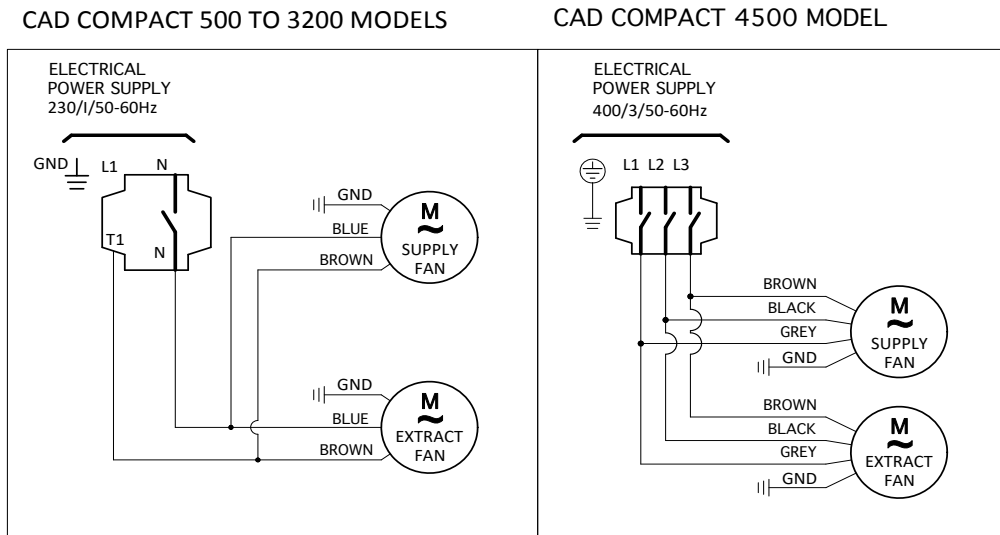

Control wiring

The wiring will depend on the needs of each installation as well as the accessories used for it. The following image shows the functions and identifications of the existing electrical connectors inside the electrical cabinet:

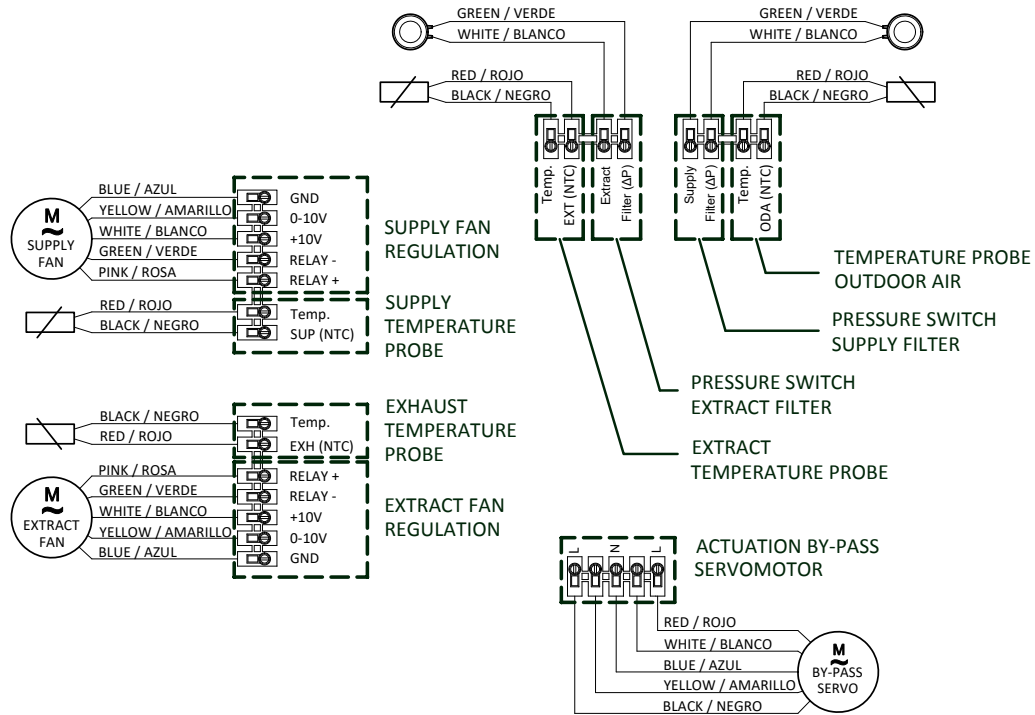

The following sections show some of the wiring used for the most common regulations.

6.6.2. Fan operation without speed regulation. Operation at maximum speed

In case that electrical accessories are not used, to regulate the fans speed, it is possible to force their maximum speed by bridging the terminals +10V and 0-10V on each fans.

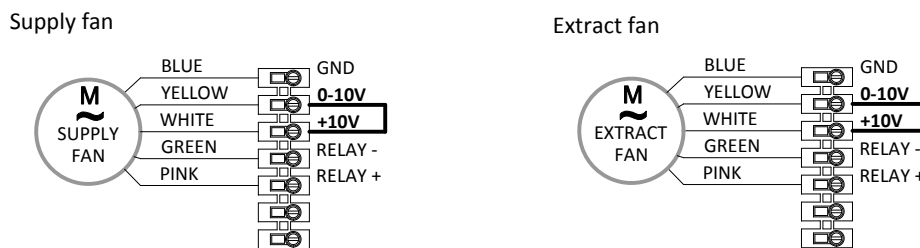

WITHOUT JUMPER, THE FANS WILL NOT BE RUNNING EVEN IF THEY ARE POWERED.

6.6.3. Connecting electrical accessories

With the existing accessories is possible to perform the fans control as well as the automatic control in VAV (variable airflow) and COP (constant pressure) modes.

Recommended accessories depending on the unit size and the control mode

Model	Accessories for the Variable Air Volume System for CO ₂		Accessories for constant pressure operation		Accessories for speed manual control
	Inverter	Sensor	Inverter	Probe	Electronic regulator
CAD COMPACT 500 to 4500	CONTROL CAD-REG	AIRSENS CO ₂ / SCO ₂ -AD 0-10V / SCO ₂ -G 0-10V/	CONTROL AERO-REG**	TDP-D*	REB-ECOWATT**

* For independent control of the working point of each circuit, the supply and extraction fans must be independently controlled by regulator and pressure probe.

** For independent control of the working point of each circuit, the supply and extraction fans must be controlled with its corresponding electronic regulator.

6.6.3.1. VAV control (Variable airflow), manual adjustment

It is possible to control in VAV mode manually with an external potentiometer. Manual control by external potentiometer REB-ECOWATT (accessory).

6.6.3.1.1. Manual adjustment by REB-ECOWATT (accessory)

Simultaneous control of the supply and extract fans

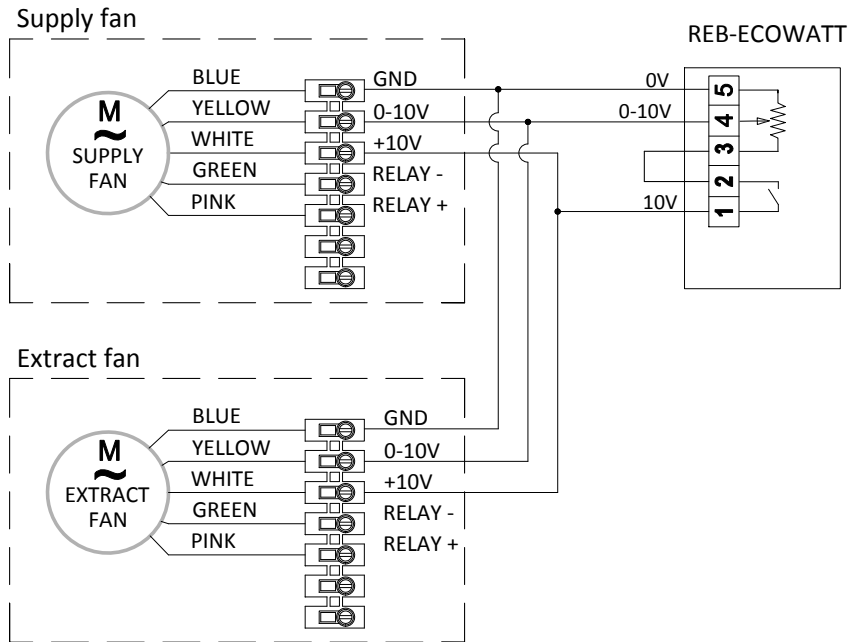

Independent control of supply and extract fans

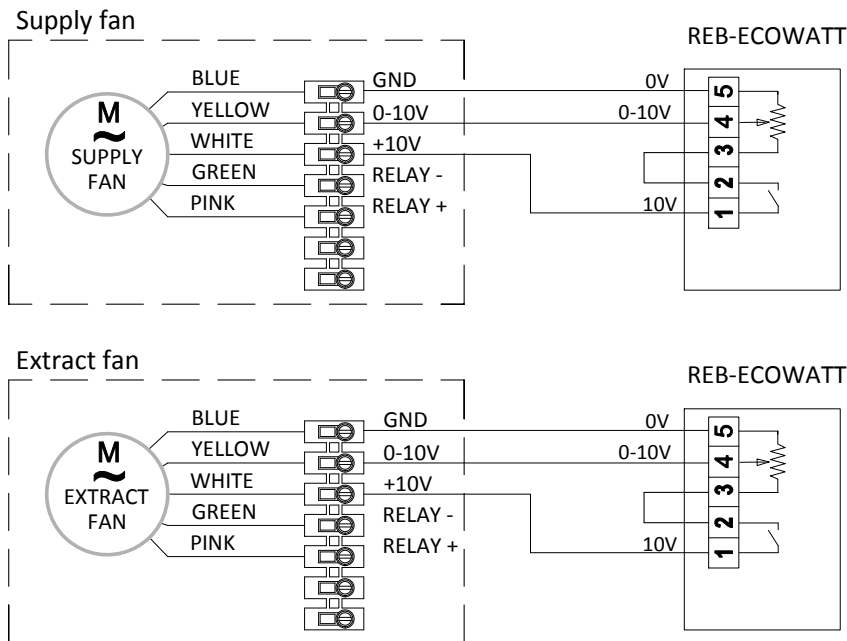

6.6.3.2. VAV Control (variable airflow), with CO₂ sensor or similar

CAD-COMPACT units are equipped with EC motors. The motors have specific terminals for sending a regulation signal to control fan speed (0-10V). The 0V signal corresponds to the fan stop, while the signal of 10V corresponds to fan maximum speed.

To perform the speed regulation in VAV with speed control with external sensor of CO₂ or similar, it is necessary to use the accessory CONTROL CAD-REG and the external sensor (see point 7.5.2.4.). In the CONTROL CAD-REG instruction booklet it is contained the necessary information to carry on the electrical connection of the different components.

6.6.3.3. CAV control (constant airflow)

The inverter is used to guarantee an specific constant air volume in the duct system, regardless of the filters clogging state.

CAD-COMPACT units are equipped with EC motors. The motors have specific terminals for sending a regulation signal to control fan speed (0-10V).

The 0V signal corresponds to the fan stop, while the 10V signal corresponds to the maximum fan speed.

To perform speed regulation in pressure or constant airflow mode, it is necessary to use the CONTROL AERO-REG accessory and the corresponding external TDP-D sensor.

- 1º Connect the pressure transmitter TDP-D (accessory) to the specific pressure taps there are in the heat recovery unit. Ensure that pressure taps “+” and “-” of the pressure transmitter concides with those of the heat recovery unit.

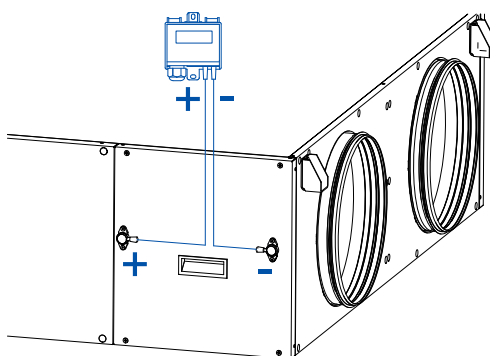

- 2º Perform the electrical connection and regulator configuration, following the instructions of the CONTROL AERO-REG accessory.

- 3º Reconfigure the pressure transmitter. So that the regulation is correct and the transmitters correctly visualize the airflow, it is necessary that it is configured to work in airflow mode with a range of 9,999 m³/h.

Adjustment to work in airflow mode

The selection between pressure and airflow is made by the DIP3(SW1) micro switch existing inside the micro switch. Fix the micro switch in ON position.

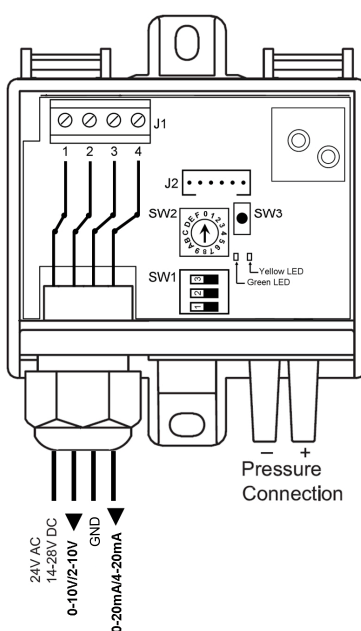

Indicate the airflow range

Once configured the airflow measurement, press the “OK” button to set the first digit of factor k. The value flashes and is adjusted using the buttons “▲” and “▼”. When set, press the “OK” button to memorise the factor k. The actual measured value is displayed. If a airflow range is selected it is not necessary to enter a range of pressures.

Model	K factor
CAD-COMPACT 500	28
CAD-COMPACT 900	59
CAD-COMPACT 1300	55
CAD-COMPACT 1800	58
CAD-COMPACT 2500	120
CAD-COMPACT 3200	93
CAD-COMPACT 4500	177

6.6.3.4. COP Control (constant pressure)

Constant Pressure (COP)

This type of regulation is associated to multi-zone ventilation systems in which ventilation multi-room is carried out by a single heat recovery unit. Flow regulation per zone is done using motorized dampers, so speed regulation of the fans aims to maintain a constant pressure in the ductwork. The value of this pressure must be determined by experimenting during the system start-up process.

CAD-COMPACT units are equipped with EC motors. The motors have specific terminals for sending a regulation signal to control fan speed (0-10V).

The 0V signal corresponds to the fan stop, while the signal of 10V corresponds to fan maximum speed.

To perform the speed regulation in COP mode, it is necessary to use the accessory CONTROL AERO-REG and the external pressure sensor TDP-D. In the CONTROL AERO-REG instruction booklet it is contained the necessary information to carry on the electrical connection of the different components.

1º Connect the pressure transmitter TDP-D (accessory) to the duct system where the heat recovery unit is ducted. Ensure that pressure taps “+” and “-” coincide with those of the heat recovery unit:

Position of the pressure taps of the TDP-D transmitter in COP systems with control of the extraction pressure

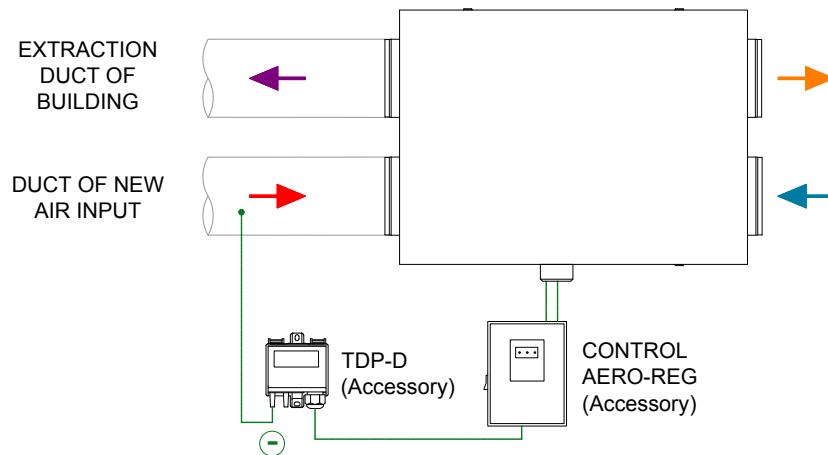

Position of the pressure taps of the TDP-D transmitter in COP systems with control of the supply pressure

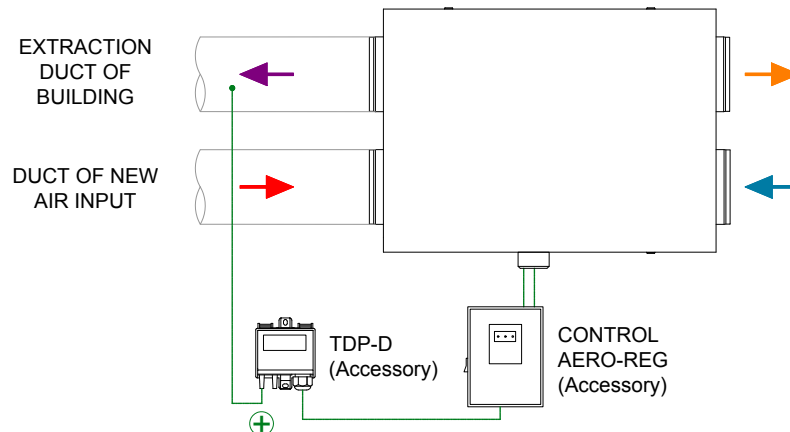

6.6.3.5. Pressure switch connection

All CAD-COMPACT range of heat recovery units have differential pressure switches to perform the control of polluted filters. The pressure switches are located inside the equipment and wired to the electrical cabinet. If you want to obtain specific information on the status of the filters through (light or sound indication), it is possible to carry out an electrical operation by passing the power line through the filter contact.

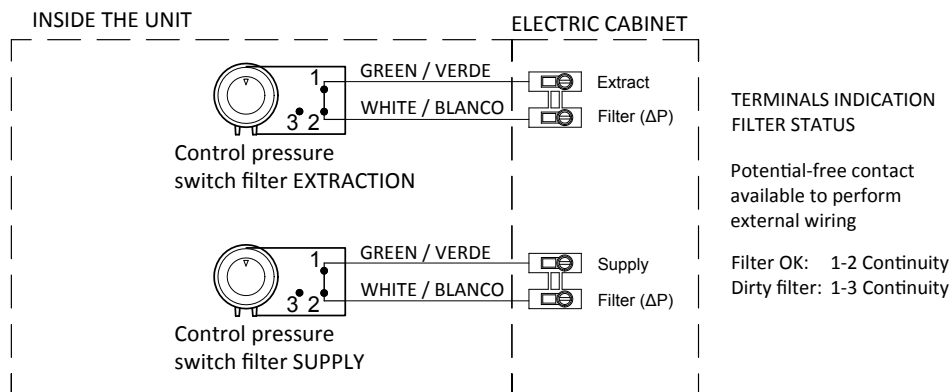

In any case, it is recommended to use a CONTROL CAD-REG or CONTROL AERO-REG control accessory that, in addition to the filter supervision functions, integrates other functionalities such as speed regulation, fan fault control, modbus communication, etc.

Detail of the connection to the CONTROL CAD-REG to enable the control of clogged filters:

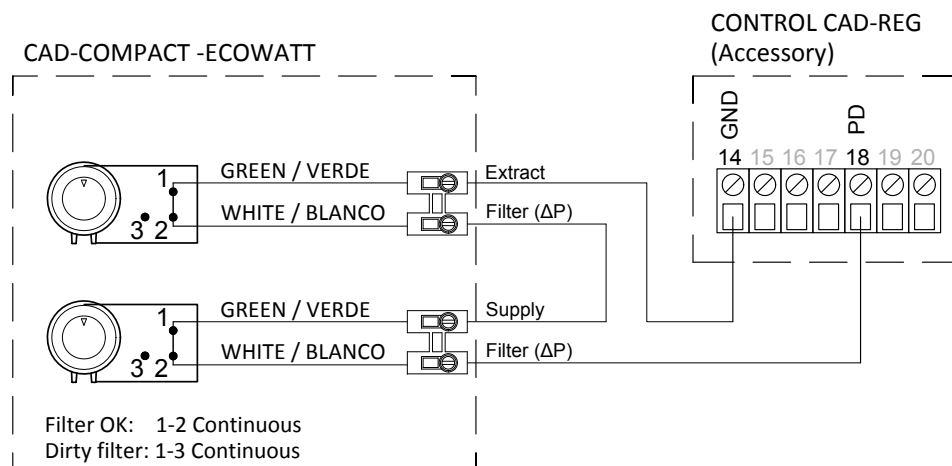

Detail of the connection to the CONTROL AERO-REG to enable the control of clogged filters:

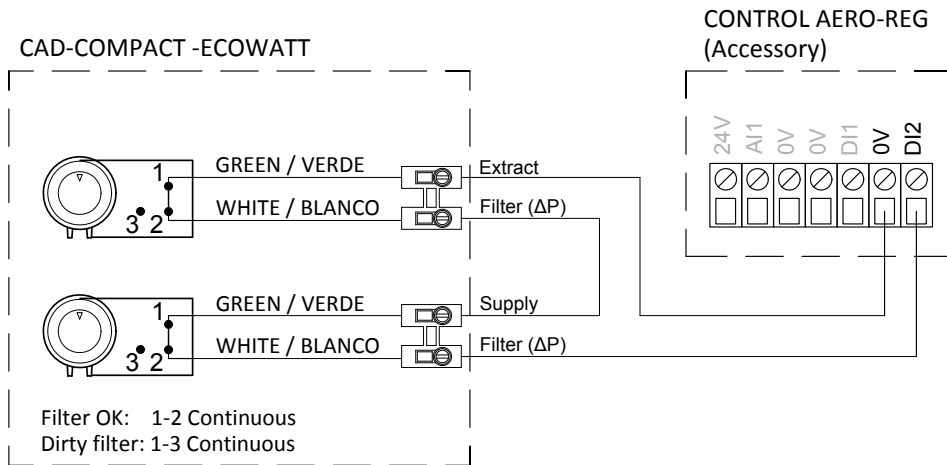

6.7. REVERSE OUTDOOR AIR / INDOOR AIR SIDE

In all units it is possible to reverse the supply and extract air sides.

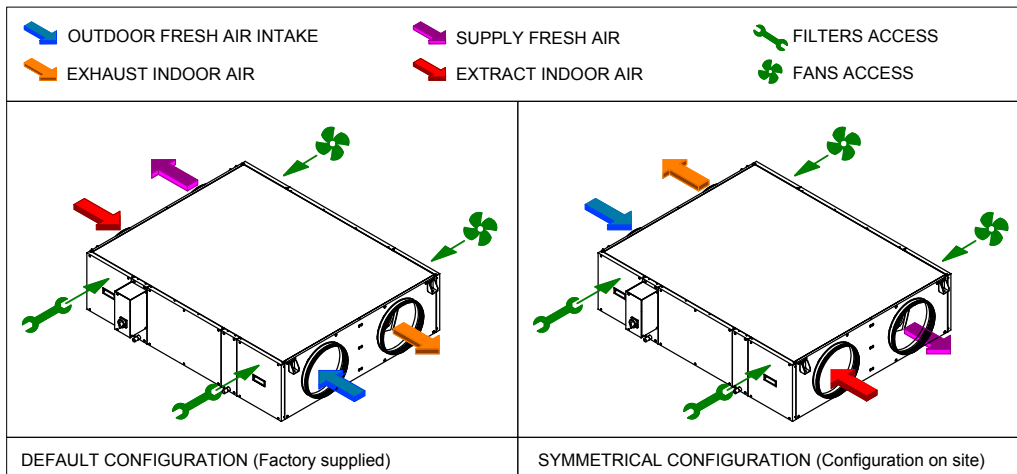

To carry on this modification it is necessary to make the following modifications to the unit:

1. Exchange the supply and extract filters as well as the access covers to the filters.
2. Replace the labels that identify the function of the air inlet/outlet. To do this, a new set of labels is supplied with the unit.

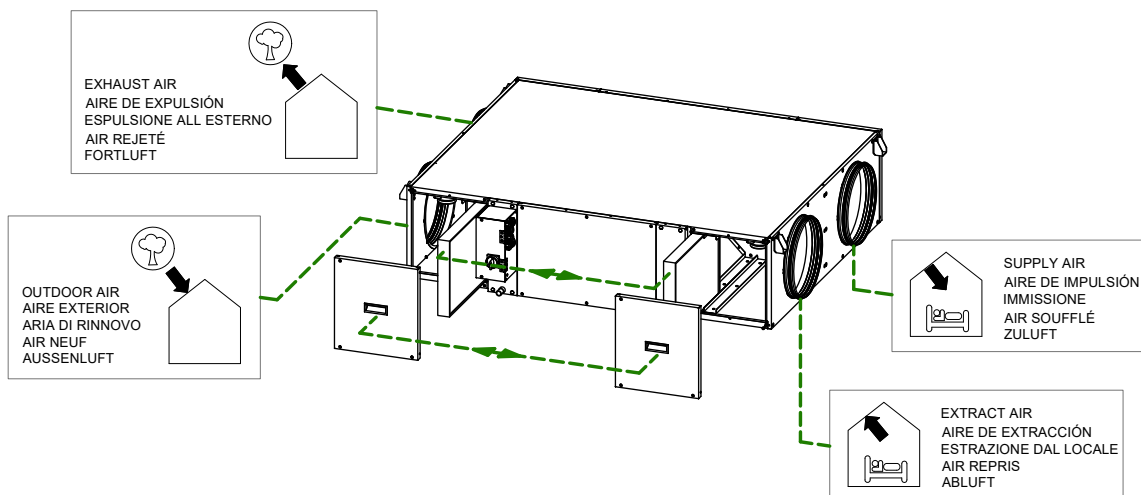

3. Replace the electrical connection label existing in the back side of the electrical terminal box with the one symmetrical label supplied in the accessory bag.
4. Only in cold climates where by-pass is used as part of the defrost strategy of the heat exchanger: Reverse the direction of the by-pass so that it remains at the supply of the unit.
 1. Disconnect the heat recovery unit.
 2. Remove the side panel (fig.1).
 3. Extract carefully the bypass (fig.2).
 4. Disconnect the electrical connector that feeds the bypass.
 5. Turn the bypass according to image (fig.3 and 4).
 6. Reconnect the electrical power connector of bypass.
 7. Place the bypass in its housing again (fig.5), close the panel and start up the unit.

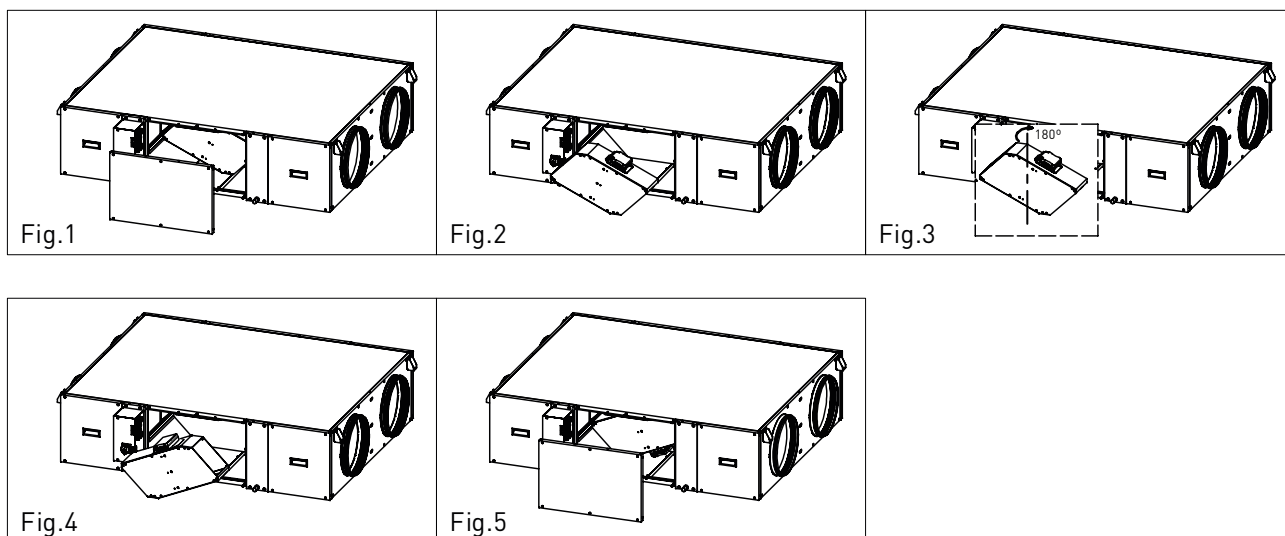

7. INSPECTION, MAINTENANCE AND CLEANING

7.1. FILTERS REPLACEMENT

The registers ubication for filters maintenance depends on the model and version. The exact ubication of the filters is identified by a label in the profile that indicates the type of filter and its characteristics.



FALLING OBJECTS

By loosening the screws that hold the panels, they will be released. In units installed in ceiling, pay special attention to this operation to prevent the fall of a panel. During the maintenance signaling the area below the heat recovery unit and prevent personnel access to it.

Access to filters is done by removing the two registration panels located on the side of the heat recovery unit. To replace the filters, follow the following sequence:

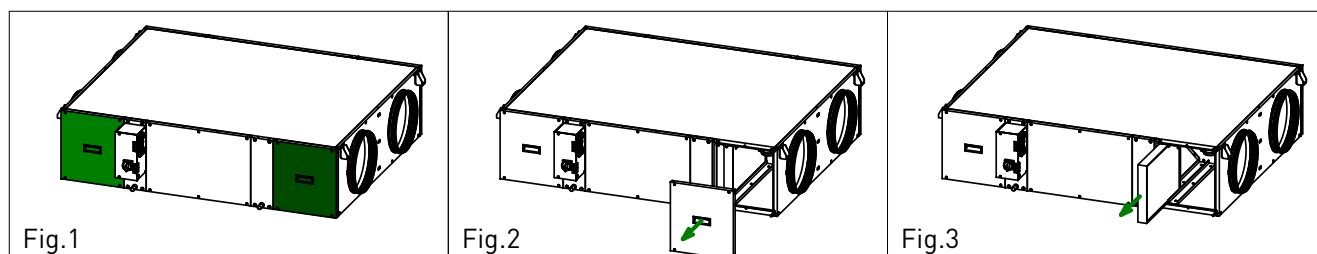

1. Access to the filters is done by removing the two existing side panels on the side where the electrical cabinet is located (Fig.1).
2. Remove the 4 screws that fix the filter access panel. Hold the panel preventing it from falling when loosening the last screw. (Fig 2).
3. Pull the dirty filter outwards, sliding it on the existing guide.

In the process of assembling the new filter, follow the reverse order, paying attention to the arrow that defines the direction of the air that you will find in the new S&P filter.

Filters spare parts table

Model	Accessory filters and spare parts for CAD-COMPACT*			
	G4	M5	F7	F9
CAD COMPACT 500	AFR-CAD COMPACT 500 G4	AFR-CAD COMPACT 500 M5	AFR-CAD COMPACT 500 F7	AFR-CAD COMPACT 500 F9
CAD COMPACT 900	AFR-CAD COMPACT 900 G4	AFR-CAD COMPACT 900 M5	AFR-CAD COMPACT 900 F7	AFR-CAD COMPACT 900 F9
CAD COMPACT 1300	AFR-CAD COMPACT 1300 G4	AFR-CAD COMPACT 1300 M5	AFR-CAD COMPACT 1300 F7	AFR-CAD COMPACT 1300 F9
CAD COMPACT 1800	AFR-CAD COMPACT 1800 G4	AFR-CAD COMPACT 1800 M5	AFR-CAD COMPACT 1800 F7	AFR-CAD COMPACT 1800 F9
CAD COMPACT 2500	AFR-CAD COMPACT 2500 G4	AFR-CAD COMPACT 2500 M5	AFR-CAD COMPACT 2500 F7	AFR-CAD COMPACT 2500 F9
CAD COMPACT 3200	AFR-CAD COMPACT 3200 G4	AFR-CAD COMPACT 3200 M5	AFR-CAD COMPACT 3200 F7	AFR-CAD COMPACT 3200 F9
CAD COMPACT 4500	AFR-CAD COMPACT 4500 G4	AFR-CAD COMPACT 4500 M5	AFR-CAD COMPACT 4500 F7	AFR-CAD COMPACT 4500 F9

* In serial, the units are supplied with F7 as standard and M5 as extraction. All models allow the assembly of a second filter inside, obtaining, among others, the following combinations: F7 + F9, M5 + F7 or G4 + F7.

7.2. ADDITIONAL FILTER INSTALLATION

The heat recovery is supplied with mounted filters.

Low pressure F7 filter for supply air and M5 for extract air.

Inside the heat recovery unit there is a specific rail for mounting a second additional filter (supplied as an accessory).

7.3. HEAT EXCHANGER

To perform the heat exchanger cleaning it is necessary to remove it from the unit. The disassembly can be easily done from the lateral panel:

Core disassembly sequence per side

To disassemble of the heat exchanger follow the following sequence:

- Loosen the screws that hold the side panel. Before releasing the panel, ensure that it is well supported by the operator, preventing it from falling (Fig. 1).
- Remove the bypass assembly, releasing its electrical connector (Fig. 2).
- Pull the heat exchanger until it is completely removed from the equipment (Fig. 3).

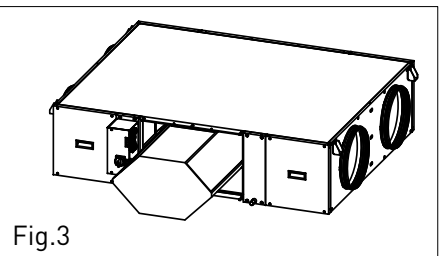
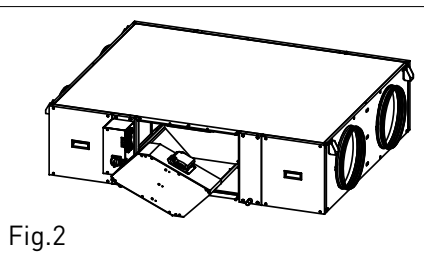
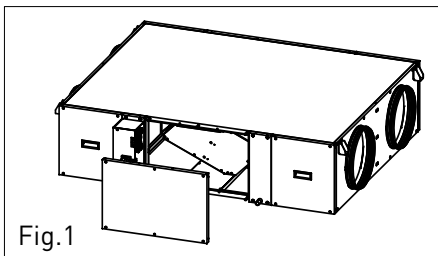

7.4. FANS

It is not necessary to access the fan to carry out maintenance tasks, nor to carry out the electrical connection since both fans are wired to the electrical cabinet. However, it is necessary to leave enough space around the equipment so that it is possible to access the fans in the event of their failure. Do not install the heat exchanger against a wall or an obstacle that prevents access to the fans.

In case of need to replace the fan, follow the following sequence:

- Remove the access panel for the affected fan (Fig. 1).
- Release the screws that lock the metal plate on which the fan is mounted (Fig. 2).
- Pull out the plate and once outside, remove the fan and proceed to replace it (Fig. 3).

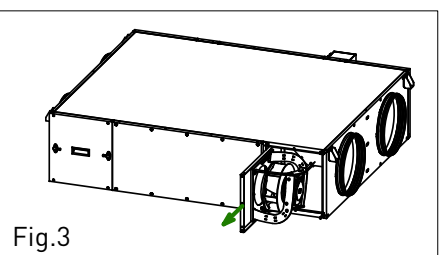
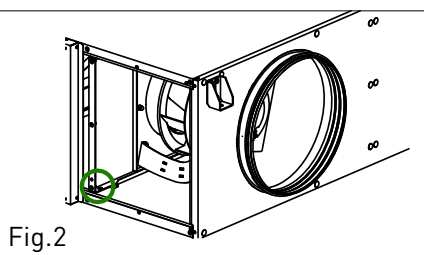
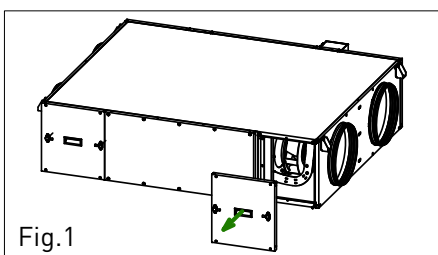

7.5. CONDENSATION DRAINPIPE

Inspect the drainpipe regularly and make sure it is not blocked, if this is the case, remove the obstruction. Check that the drain pipe was done according to the indication included in the point CONNECTIONS of this manual. The siphon should always be full of water. Check its level periodically, refilling it if necessary. An empty siphon can cause the condensate tray to overflow and water leak through the equipment enclosure.

8. OPERATION ANOMALIES

8.1. GENERAL ANOMALIES

Anomaly	Cause	Solution
Difficult to start.	Reduced power supply voltage. Insufficient static torque of motor.	Check motor specification plate. Close the air inlets to reach the maximum speed. Change the motor is necessary. Contact the S&P Post-Sales service.
Insufficient airflow. Insufficient pressure.	Blocked pipes and/or inlet points closed. Fan obstructed. Filter overloaded. Insufficient rotation speed. Exchanger package blocked.	Clean inlet tubes. Clean fan. Clean or replace filter. Check power supply voltage. Clean the exchanger.
Reduction in performance after a period of acceptable operation.	Leaks in the circuit before and/or after the fan. Damaged roller.	Check the circuit and restore original conditions. Check the impeller and if necessary, replace with an original spare part. Contact the S&P post sales service.
New air temperature too cold.	Outside air -5°C or less.	Insertion of post-heating resistances. Contact the S&P post sales service.
Insufficient performance of the exchanger.	Fins dirty.	Clean the exchanger.
Formation of frost on the exchanger.	Outside air below -5°C.	Insertion of pre-heating devices (anti-ice). Contact the S&P Customer Advice service.
Air pulsation.	Fan working in excessively low flow conditions. Flow instability, obstruction or bad connection.	Modification of the circuit and/or replacement of the fan. Clean and/or readjust the inlet channels. Operate the electronic regulator, increasing the minimum speed (insufficient voltage). Contact the S&P Customer Advice service.
There is water inside the unit.	Drain clogged or wrongly dimensioned.	Check if exists a body/object obstructing the passage of water and remove it. Verify that the drain trap exists and is correctly sized according to the instructions of this manual.



S&P SISTEMAS DE VENTILACIÓN, S.L.U.

C. Llevant, 4
Polígono Industrial Llevant
08150 Parets del Vallès
Barcelona - España

Tel. +34 93 571 93 00
www.solerpalau.com



Ref. 9023119000