



# CAD-COMPACT ADVANCED





## INDEX

---

1. INTRODUCTION .....	5
2. SAFETY REGULATIONS AND "CE" MARKING .....	5
3. GENERAL INSTRUCTIONS .....	5
4. UNIT LABELLING .....	5
5. HANDLING .....	6
6. INSTALLATION .....	6
6.1. Introduction .....	6
6.1.1. Outdoor installation .....	8
6.2. Dimensions and free space for maintenance .....	10
6.2.1. Dimensiones.....	10
6.2.2. Free space for maintenance .....	12
6.3. Mounting process of an additional supply filter .....	12
6.4. Range specifications .....	13
6.5. Connections .....	13
6.5.1. Connection with air duct .....	13
6.5.2. Condensate drainage .....	13
6.5.3. Electrical connection .....	14
6.5.3.1. External Touch Display (ETD) control connection.....	14
6.5.4. Connecting electrical accessories .....	16
6.5.4.1. VAV Control (variable airflow), with CO <sub>2</sub> sensor or similar .....	16
6.5.4.2. COP Control (constant pressure).....	16
6.5.4.3. CAV Control (constant airflow) .....	18
6.6. Reverse outdoor air / indoor air side .....	18
7. CONTROL SCHEMES .....	20
8. CONTROL ADVANCED OPERATION .....	23
8.1. Description .....	23
8.2. Main functions .....	23
8.3. Use of remote terminal - user level.....	24
8.3.1. Navigation.....	24
8.3.2. Access levels .....	25
8.3.3. Quick access functions.....	25
8.3.3.1. Fan speed adjustment .....	26
8.3.3.2. Set temperature setting .....	27
8.3.4. Main menu.....	27
8.3.5. Information menu .....	29
8.4. Unit configuration.....	31
8.4.1. Change the idiom .....	31
8.4.2. Setting the system date / time.....	31
8.4.3. Image and sound settings.....	31
8.4.4. Time schedule .....	32
8.4.5. Unit configuration - installer parameters .....	36
8.4.6. Fans working modes .....	37
8.4.6.1. Variable flow operation (VAV).....	38
8.4.6.2. Constant pressure operation (COP) .....	40
8.4.6.3. Constant flow operation (CAV).....	41



8.4.7. Regulated output settings .....	43
8.4.8. Filter supervision.....	44
8.4.9. Exchange the function of the supply and extraction circuits.....	45
8.4.10. Boost function.....	46
8.4.11. Remote Stop-Start.....	47
8.4.12. Protection of heat exchanger unit.....	47
9. FIRE FUNCTION (FIRE) .....	47
10. CONTROL OF EXTERNAL COILS AND BATTERIES (HEATING / COOLING) .....	48
10.1. Wiring between accessory and advanced electrical board.....	50
10.1.1. Post-heating and post-cooling battery modules.....	50
10.2. Configuration of external modules of refrigeration / heating batteries.....	50
10.2.1. Configuration of an external post-heating water coil.....	51
10.2.2. Configuration of an external heating coil (post-heating).....	52
10.2.3. Configuration of an external water cooling coil (post-cooling).....	53
10.2.4. Configuration of an external electric preheating coil.....	54
11. UPDATE THE CONTROLLER .....	55
12. CONTROLLER RECONFIGURATION.....	56
13. BUILDING MANAGEMENT SYSTEM (BMS) connection .....	57
14. INSPECTION, MAINTENANCE AND CLEANING .....	65
14.1. Filters replacement.....	65
14.2. Additional filter installation.....	66
14.3. Heat exchanger.....	66
14.4. Fans .....	67
14.5. Condensation drainpipe .....	67
15. OPERATION ANOMALIES .....	68
15.1. General anomalies .....	68
15.2. List of alarms.....	68
16. WIRING DIAGRAMS .....	71
16.1. CAD-COMPACT 500 to 2500 advanced. Configuration by default. Supply air fan at left side (seen from the electrical cabinet).....	71
16.2. CAD-COMPACT 500 to 2500 advanced. Symmetric configuration. Supply air fan at right side (seen from the electrical cabinet) .....	72
16.3. CAD-COMPACT ADVANCED 3200. Default configuration. Supply air fan on the left side (seen from the electrical cabinet).....	73
16.4. CAD-COMPACT ADVANCED 3200. Symmetric configuration. Supply air fan on the right side (seen from the electrical cabinet) .....	74
16.5. CAD-COMPACT 4500 ADVANCED. Configuration by default. Supply air fan at left side (seen from the electrical cabinet).....	75
16.6. CAD-COMPACT ADVANCED 4500. Symmetric configuration. Supply air fan at right side (seen from the electrical cabinet) .....	76
16.7. Specific wiring to control external coils.....	77
16.7.1. Configuration by default. Supply air fan at left side (by default).....	77
16.7.2. Symmetric configuration. Supply air fan at right side .....	77
16.8. Specific wiring to control post-heating electric batteries .....	78
16.8.1. Default configuration. Supply air fan on the left side.....	78
16.8.2. Symmetric configuration. Supply air fan on the right side .....	79
16.9. Specific wiring to control external electric preheating batteries.....	79



## 1. INTRODUCTION

---

Thank you for purchasing this appliance. It has been manufactured in full compliance with applicable safety regulations and **EU** standards.

Please read this instruction book carefully, as it contains important information for your safety during the installation, use and maintenance of this product.

Keep it at hand for future reference.

Please check that the appliance is in perfect condition when you unpack it, as all factory defects are covered by the **S&P** guarantee.

## 2. SAFETY REGULATIONS AND “CE” MARKING

---

**S&P** technicians are firmly committed to research and development of ever more efficient products and in compliance with current safety regulations.

The instructions and recommendations given below reflect current regulations, principally regarding safety, and therefore are based on compliance with general regulations. Therefore, we recommend all people exposed to hazards to strictly follow the safety regulations in force in your country.

**S&P** will not be held liable for any possible harm or damage caused by non-compliance with the safety regulations, as well as caused by modifying the product.

The **CE** mark and the corresponding declaration of conformity are proof of the product's conformity with current EU regulations.

## 3. GENERAL INSTRUCTIONS

---

A hazard analysis of the product has been carried out as provided in the Machine Directive. This manual contains information for all personnel exposed to these hazards, with the aim of preventing possible harm or damage due to faulty handling or maintenance.

All maintenance operations (ordinary and extraordinary) must be carried out with the machine switched off and the electrical power supply disconnected.

To avoid a possible accidental start up, place a warning notice on the electrical control panel with the following text:

**“Attention: control disconnected for maintenance operations”**

Before connecting the power supply cable to the terminal strip, make sure the mains voltage corresponds to the voltage indicated on the specifications plate of the unit.

Regularly check the product labels. If, due to the passing of time, they are no longer legible, they must be replaced.

## 4. UNIT LABELLING

---

The machine may come with several pictograms that must not be removed. These signs are divided into:

- **Prohibition signs:** Do not repair or adjust when in operation.
- **Danger signs:** Warning of the presence of live elements inside the container bearing the sign.
- **Identification signs:** CE card, indicating product information and manufacturer's address. The **CE** mark indicates the product's conformity with **EEC** standards.



Danger signs



Prohibition signs

## 5. HANDLING

---

The CAD-COMPACT ADVANCED units are delivered fixed with screws to the pallets. The handling machines will be adapted to the load and the lifting conditions. In all cases, the lifting will be done at the device's base. The centre of gravity is located at the centre of the unit. The device must be carefully manipulated only in the horizontal position.

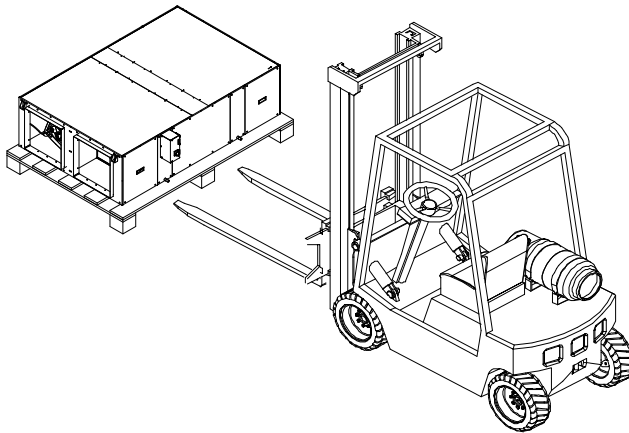

## 6. INSTALLATION

---

### 6.1. Introduction

All models are designed to be installed hanging from the ceiling or located behind a false ceiling. When installing the unit, it is necessary to distribute the unit weight between the 4 supports existing in the units.

Using studded rods ( $\varnothing$  8 mm), it can be secured to the ceiling and levelled:

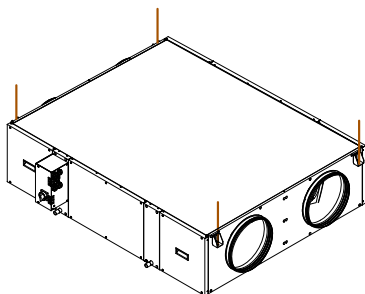

Check the distances between supports in the diagrams of the section: "Dimensions and free dimensions for maintenance".

The installer must make sure that the ceiling structure and the securing elements can bear the weight of the device, taking into account that it is a dynamic load.

To prevent the transmission of vibrations from the unit to the rest of the installation, it is necessary that the installer use specific isolation elements, as well as flexible couplings between the water connections and the pipelines.

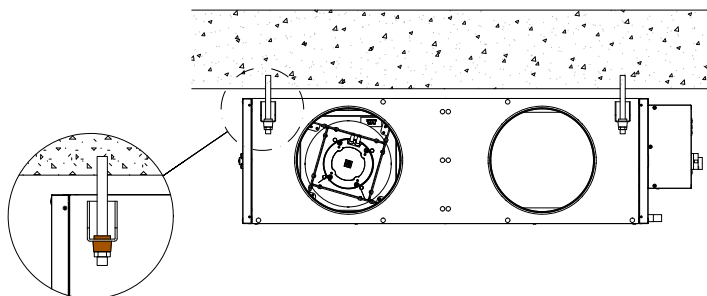

Model	Total weight of unit (kg)	Anti vibration kit support (Composed of 4 pcs.)
CAD-COMPACT 500	70	KIT AM CAD-COMPACT
CAD-COMPACT 900	86	KIT AM CAD-COMPACT
CAD-COMPACT 1300	137	KIT AM CAD-COMPACT
CAD-COMPACT 1800	145	KIT AM CAD-COMPACT
CAD-COMPACT 2500	235	KIT AM CAD-COMPACT
CAD-COMPACT 3200	235	KIT AM CAD-COMPACT
CAD-COMPACT 4500	336	KIT AM CAD-COMPACT



### 6.1.1. Outdoor installation

The CAD-COMPACT ADVANCED range is advisable to be mounted indoors. Outdoor mounting is limited to areas with less extreme climates. When it is installed outdoors, it is preferable to place the unit under a cover which offers enough protection to prevent rain falling directly to the unit, or install the corresponding rain canopy (accessory). If installed on the ground, sufficient space must be guaranteed under the unit so that it is possible to install the corresponding siphons in the condensate outlets of the unit.

There is a Kit composed of 4 feet, which facilitates the installation on floor of these versions: KIT PIES CAD-COMPACT.

Both in the case that the KIT PIES CAD-COMPACT is used, and if the unit is based on vibrators or supports made on site, it is essential that the heat exchanger's support is guaranteed on 4 existing support points (4 pcs. in the corners of the unit).

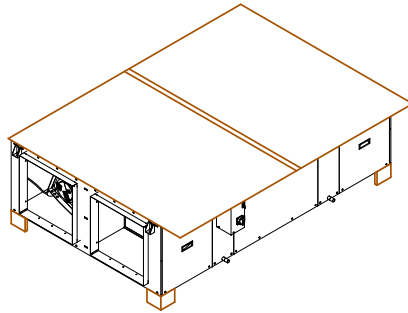

Detail of a CAD-COMPACT with the corresponding canopy and the kit of feet.

List of necessary accessories recommended for outdoor installation:

Model	Kit feet	Roof
CAD-COMPACT 500	KIT PIES CAD-COMPACT	TPP-CAD-COMPACT 500
CAD-COMPACT 900	KIT PIES CAD-COMPACT	TPP-CAD-COMPACT 900
CAD-COMPACT 1300	KIT PIES CAD-COMPACT	TPP-CAD-COMPACT 1300
CAD-COMPACT 1800	KIT PIES CAD-COMPACT	TPP-CAD-COMPACT 1800
CAD-COMPACT 2500	KIT PIES CAD-COMPACT	TPP-CAD-COMPACT 2500
CAD-COMPACT 3200	KIT PIES CAD-COMPACT	TPP-CAD-COMPACT 3200
CAD-COMPACT 4500	KIT PIES CAD-COMPACT	TPP-CAD-COMPACT 4500



### Assembly of the canopy

There are 2 types of canopy: Small models: TPP-CAD COMPACT 500 to 1800 and large models: TPP-CAD COMPACT 2500 to 4500.

In both cases the canopy is supplied as a single piece. On-site work is limited to assembling the canopy on the recovery unit following the sequence:

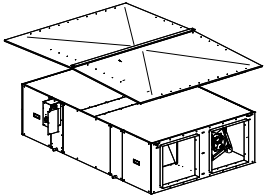
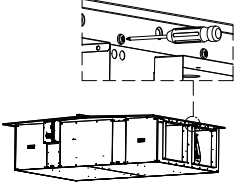
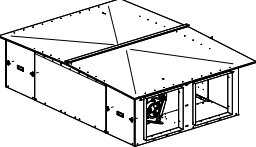
		
<p>Place the canopy on the recovery unit</p>	<p>Fix the canopy to the heat recovery unit using the screws supplied with the canopy</p>	<p>Image of the recovery unit with the canopy once mounted. The image corresponds to CAD COMPACT 4500</p>

In addition to the roof and Kit feet, it is necessary to equip the duct network with rain hoods or air intakes equipped with anti-bird mesh to prevent the entry of animals or objects into the heat recovery unit.

### Avoid condensations in electrical cabinet

In units located outdoors in which the heat recovery units is stopped during the night or during long intervals of time, it is necessary to:

- a) Install isolation dampers in the outdoor air inlet and air discharge.
- b) Add anticondensation devices inside the electrical cabinet as: cabinet heating elements that prevent condensation formation on cabinet surfaces and electronic components. As alternative, maintain the electronic under voltage, this way the own heating produced by the electronic will avoid the condensation formation.



## 6.2. DIMENSIONS AND FREE SPACE FOR MAINTENANCE

### 6.2.1. Dimensiones

#### a) CAD-COMPACT 500 to 1800 models

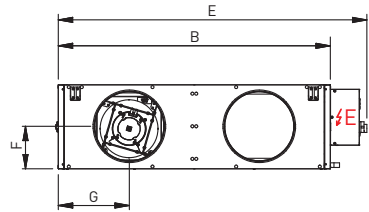
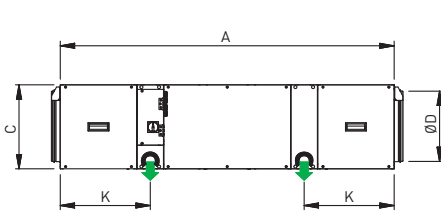

#### TOP VIEW

BY DEFAULT (FACTORY SUPPLY)

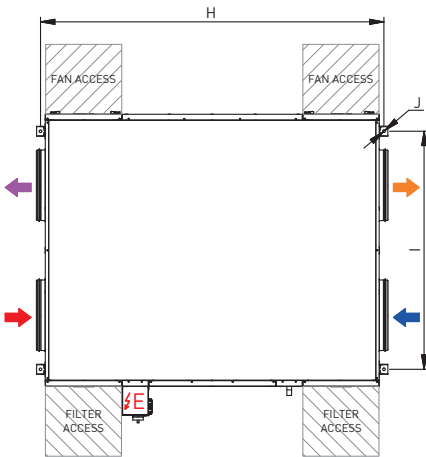

CONFIGURATION RESULT OF SIMPLE MODIFICATION ON SITE

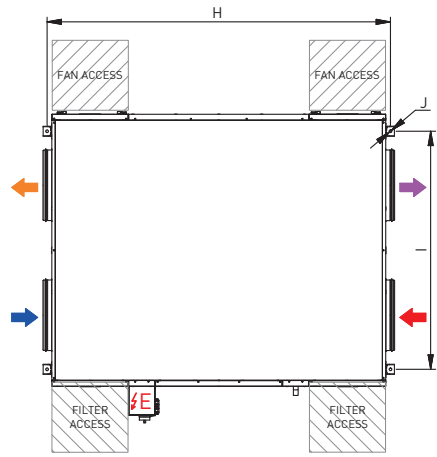

- ELECTRICAL CABINET
- OUTDOOR AIR INTAKE
- SUPPLY FRESH AIR
- EXTRACT INDOOR AIR
- EXHAUST INDOOR AIR
- CONDENSATE OUTLET 1/2"

Model	A	B	C	D	E	F	G	H	I	J	K
CAD-COMPACT 500	1120	698	289	200	862	147	188	1163	546	12	256
CAD-COMPACT 900	1345	843	376	315	1007	190	225	1388	691	12	328
CAD-COMPACT 1300	1495	1218	376	315	1382	190	318	1538	1066	12	403
CAD-COMPACT 1800	1580	1083	453	355	1247	228	285	1623	931	12	393

**b) CAD-COMPACT 2500 to 4500 models**

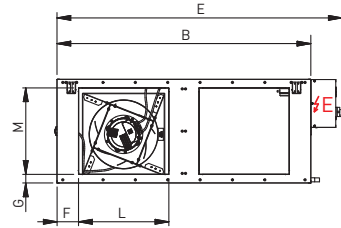
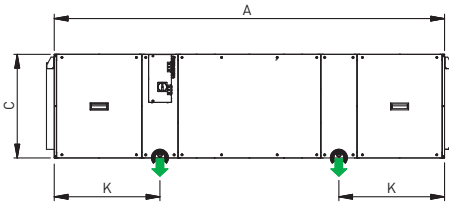

**TOP VIEW**

BY DEFAULT (FACTORY SUPPLY)

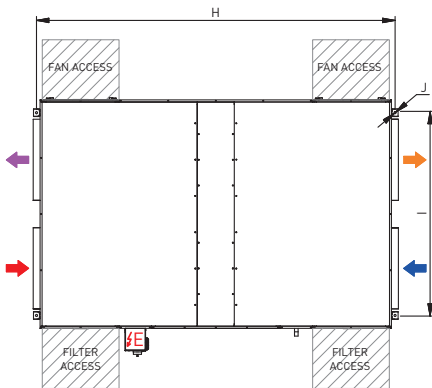

CONFIGURATION RESULT OF SIMPLE MODIFICATION ON SITE

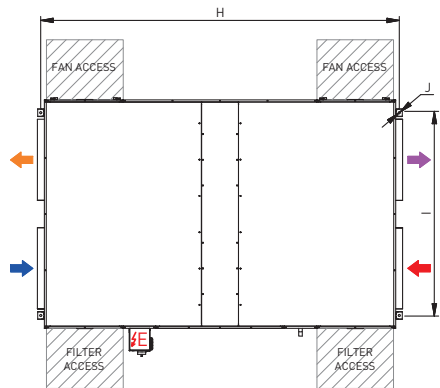

- ELECTRICAL CABINET
- OUTDOOR AIR INTAKE
- SUPPLY FRESH AIR
- EXTRACT INDOOR AIR
- EXHAUST INDOOR AIR
- CONDENSATE OUTLET 1/2"

Model	A	B	C	D	E	F	G	H	I	J	K	L	M
CAD-COMPACT 2500	1845	1495	453	-	1670	127	41	1888	1343	17	385	570	375
CAD-COMPACT 3200	2038	1325	541	-	1489	113	43	2081	1176	12	552	470	450
CAD-COMPACT 4500	2207	1993	598	-	2156	165	79	2250	1844	12	594	700	440

## 6.2.2. Free space for maintenance

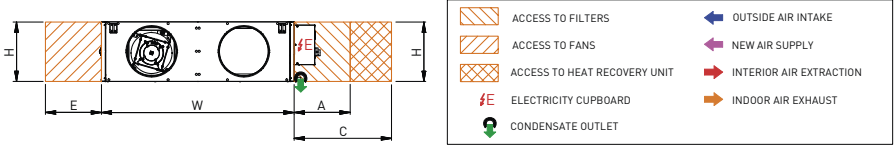

**TOP VIEW**  
BY DEFAULT (FACTORY SUPPLY)

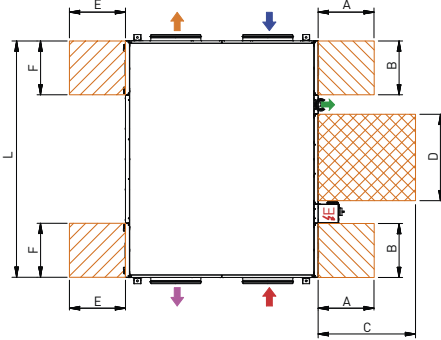

**TOP VIEW**  
CONFIGURATION RESULT OF SIMPLE MODIFICATION ON SITE

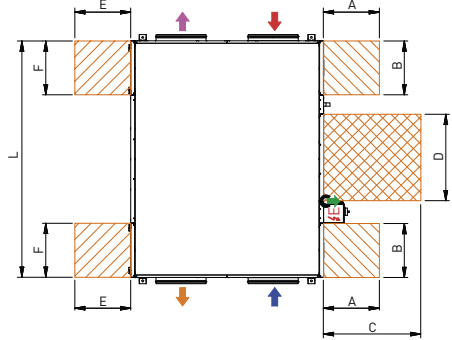

Model	Unit			Filters			Heat exchanger			Fans		
	L	W	H	H	A	B	H	C	D	H	E	F
CAD-COMPACT 500	1120	698	289	289	295	300	289	500* / 550**	487	289	500	300
CAD-COMPACT 900	1345	843	376	376	365	300	376	500* / 680**	570	376	500	300
CAD-COMPACT 1300	1495	1218	376	376	555	350	376	500* / 1020**	570	376	580	350
CAD-COMPACT 1800	1580	1083	453	453	490	350	453	500* / 820**	650	453	500	350
CAD-COMPACT 2500	1845	1495	453	453	360	350	453	500* / 650**	650	453	550	350
CAD-COMPACT 3200	2038	1325	541	541	280	300	541	500* / 550**	745	541	550	300
CAD-COMPACT 4500	2207	1993	598	598	440	450	598	500* / 820**	800	598	800	450

\* On-site inspection or cleaning (recommended)

\*\* Exchanger disassembly dimension (not recommended)

## 6.3. MOUNTING PROCESS OF AN ADDITIONAL SUPPLY FILTER

The heat recovery unit is supplied with the filters already installed. F7 (ePM1 70%) in the supply air and M5 (ePM10 50%) in the extract air. In addition, it is possible to mount a second filter in the unit (accessory) (for more information see section "Replacing filters").

## 6.4. RANGE SPECIFICATIONS

Model	Diameter connections air (mm)	Nominal airflow 150Pa** (m <sup>3</sup> /h)	Efficiency heat recovery unit* (%)	Electrical power supply	Maximum absorbed power** (kW)	Maximum current** (A)	Weight (kg)
CAD-COMPACT 500	200	440	82,2	1/230V, 50-60Hz	0,31	2,0	70
CAD-COMPACT 900	315	790	82,0	1/230V, 50-60Hz	0,45	3,2	91
CAD-COMPACT 1300	315	1.120	82,3	1/230V, 50-60Hz	0,88	4,0	120
CAD-COMPACT 1800	355	1.670	82,7	1/230V, 50-60Hz	1,02	4,2	150
CAD-COMPACT 2500	570x375	2.180	83,5	1/230V, 50-60Hz	0,92	3,9	200
CAD-COMPACT 3200	470x450	3.000	83,7	1/230V, 50-60Hz	2,00	8,7	235
CAD-COMPACT 4500	700x440	4.165	84,6	3/400V, 50-60Hz	2,76	4,2	336

\* Wet efficiency referred to nominal airflow, external conditions (-5°C 80% RH) and interior (20°C / 50% RH).

\*\* Sum of both fans.

## 6.5. CONNECTIONS

### 6.5.1. Connection with air duct

The fans are always blowing out with regard to the unit. Before making the connection of the air ducts, verify the identification labels in each inlet/outlet connection of the heat recovery units.

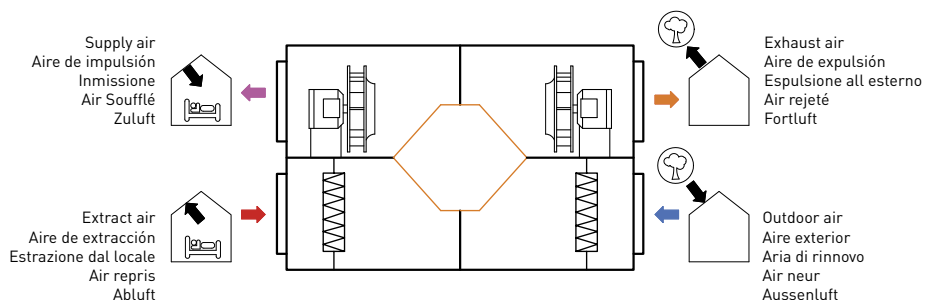

### 6.5.2. Condensate drainage

The units are supplied with 2 drains (one for each circuit). For added security it has to connect two drains to the drain pipe of the building. Drain tips are 1/2 "GM threaded.

#### Drainage system

- To ensure the removal of draining condensate from the tray, a siphon must be installed sized in the way that the distance between the water beam inside the siphon and the drain tray, will be higher than the static fan pressure.
- The horizontal sections should have a minimum slope of 2%.

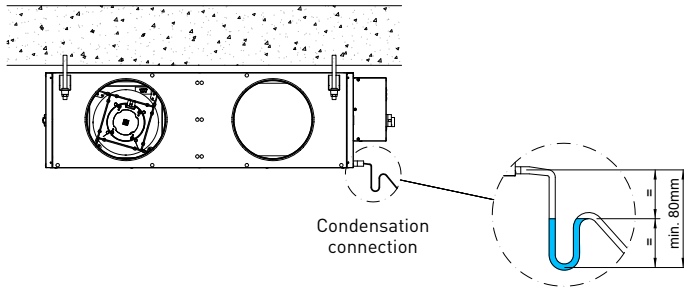

The siphon should always be full of water. Check its level periodically, refilling it if necessary. An empty siphon can cause the condensate tray to overflow and water leak through the equipment enclosure.

### 6.5.3. Electrical connection

In the recovery unit CAD-COMPACT ADVANCED range, all components integrated in the unit, are supplied wired to the electric board (fans, filters pressure switches, temperature probes and by-pass damper).

The electrical connection to be done by the installer is limited to the connection of control terminal (10 m. of cable are supplied) and possible electrical accessories such as CO<sub>2</sub> sensors and finally the connection of the power supply line directly to the main switch located on the cover of the electrical cabinet.

Make electrical connection in accordance to the described in the corresponding wiring diagram, found at the end of this manual.

It is recommended to reduce the wiring lengths of the control maneuvers in order to reduce possible effects of the environment on the control signals.

To avoid interference that may affect the operation of the unit, it is recommended that the wiring be routed away from other electrical power lines, motors, refrigeration compressors, frequency inverters or the like.

This equipment complies with the Electromagnetic Compatibility Regulations that are applicable to them.

The use of shielded cables is recommended, although in environments with a high level of electromagnetic disturbances, it may become necessary to shield the wiring using a metal tube.

#### 6.5.3.1. External Touch Display (ETD) control connection

The remote control is supplied with a 10 meter length cable, and it can be replaced by a cable up to 30 meters (recommended control cable type. H05VV-F-4G 0.25).

The ETD control has an electrical protection IP-20 degree, so it is valid; it is reserved exclusively for indoor usage sheltered from humidity.

Once the parameter setting is done, the remote control can be disconnected.

#### Remote control installation procedure

Control panel allows for surface or flush mounting:

<p>Drill holes in the wall (2) and screw in the screws (3). Then connect the control panel (1) with a wire (4), that can be placed in wall's hollow or on its surface:</p>	
<p>It is also possible wall mounting or via mounting frame:</p>	<p> <math>a = 129 \pm 0.3</math>  <math>b = 83 \pm 0.3</math>  <math>c = 1,5 \pm 0.1</math> </p>
<p>Next, connect the panel with the controller using the corresponding signal cable. To avoid interferences, the connection cable cannot be conducted along with the cables of the building mains, nor stand near devices that generate electromagnetic fields:</p>	

In wall installation, it is necessary to provide ventilation holes (2) to prevent overheating of the remote control (1).

### 6.5.4. Connecting electrical accessories

With the existing accessories it is possible to perform the fans control as well as the automatic control in VAV (variable airflow), COP (constant pressure) and CAV (constant airflow) modes.

To access the electrical terminal block and conveniently make the electrical connection of the accessories it is advisable to remove the connection board, follow the following sequence:

1. Loosen the 5 screws that are distributed by the cover of the electrical cabinet (Fig. 1)
2. Open the cover and pull the metal plate on which the electrical terminals are located until it is outside the cabinet (Fig. 2).
3. The electrical cabinet has a PG connector for the electrical power cable. Further of this, in a bag that is supplied inside the unit, there are 3 more connectors that can be used to route the control wiring to the control accessories or the control panel of the building. Pass the necessary wiring through the connectors.
4. Make the electrical connection to the control board and put it back inside the electrical cabinet, making it slide through the existing guides (Fig. 3).

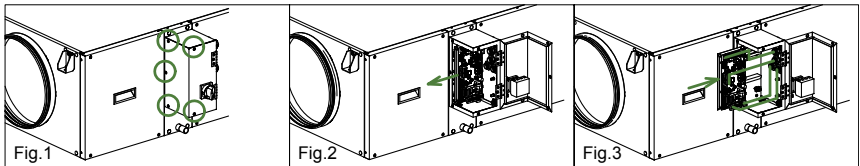

#### Recommended accessories for fan speed regulation

Variable airflow VAV by CO <sub>2</sub>		Constant pressure COP	Constant airflow CAV
Ambient	Duct		
AIRSENS CO <sub>2</sub> / SCO <sub>2</sub> -A 0-10V	SCO <sub>2</sub> -G 0/10V	TDP-S	TDP-S (2 units)

#### 6.5.4.1. VAV Control (variable airflow), with CO<sub>2</sub> sensor or similar

CAD-COMPACT ADVANCED units are equipped with EC motors. The motors have specific terminals to receive a regulation signal to control fan speed (0-10V). The 0V signal corresponds to the fan stop, while the signal of 10V corresponds to fan maximum speed.

To perform the speed regulation in VAV with speed control from an external CO<sub>2</sub> sensor or similar, it is necessary to have a sensor with 0-10V output signal (air quality, relative humidity, etc.) and connect it to the electrical panel as indicated in the instruction manual.

#### 6.5.4.2. COP Control (constant pressure)

##### Constant Pressure (COP)

This type of regulation is associated to multi-zone ventilation systems in which ventilation multi-room is carried out by a single heat recovery unit. Flow regulation per zone is done using motorized dampers, so speed regulation of the fans aims to maintain a constant pressure in the ductwork. The value of this pressure must be determined experimentally during the system start-up process.

CAD-COMPACT ADVANCED units are equipped with EC motors. The motors have specific terminals to receive a regulation signal to control fan speed (0-10V).



The 0V signal corresponds to the fan stop, while the signal of 10V corresponds to fan maximum speed.

To perform speed regulation in constant pressure mode, it is only necessary to have a pressure transmitter with a 0-2000ppm full scale and 0-10V output signal and connect it to the electrical panel as indicated in the electric diagrams. Carry out the integration of the pressure transmitters in the ductwork, as indicated in the following images:

- 1° Connect the pressure transmitter TDP-D (accessory) to the duct system where the heat recovery unit is ducted.

**Position of the pressure taps of the TDP-D transmitter in COP systems with control of the extraction pressure**

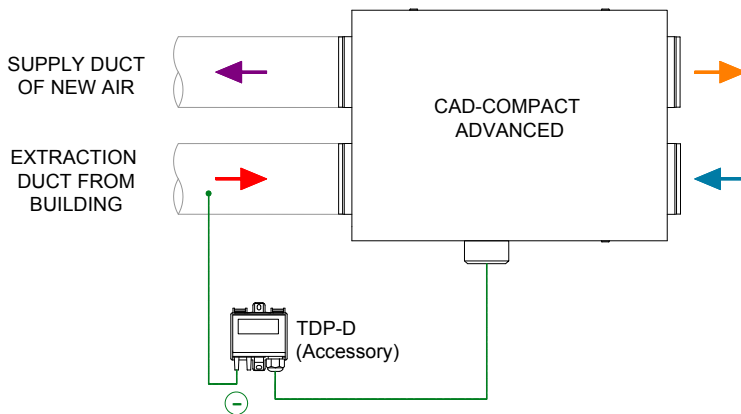

**Position of the pressure taps of the TDP-D transmitter in COP systems with control of the supply pressure**

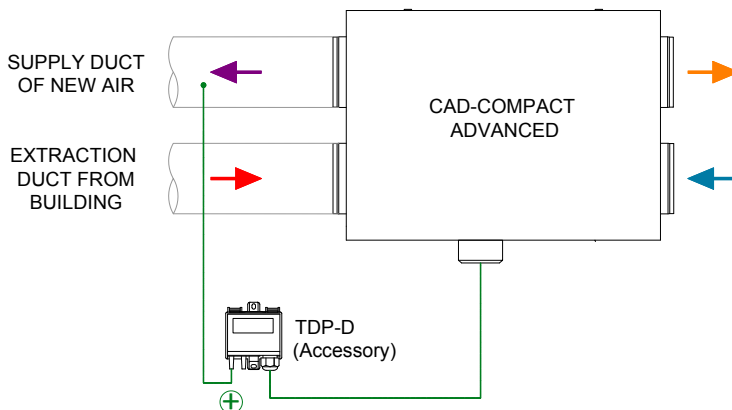

### 6.5.4.3. CAV Control (constant airflow)

This type of regulation is used to guarantee a constant airflow in the ductwork, regardless of the filters fouling state.

As it is a specific regulation for each fan, to work in mode CAV two pressure transmitters TDP-S (accessories) are required.

1. Connect the pressure transmitters TDP-S to the specific pressure taps there are in the heat recovery unit. Ensure that pressure taps “+” and “-” of the pressure transmitter coincides with those of the heat recovery unit.

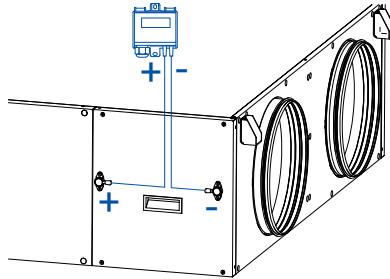

2. Wire the pressure transmitters to the electric board following the indications in the electric schemes.
3. Configure the settings specific for CAV mode control. The range setted in the controller and in the pressure transmitter must be the same.

## 6.6. REVERSE OUTDOOR AIR / INDOOR AIR SIDE

In all units it is possible to exchange the supply and extract air sides (Supply side per Extract side):

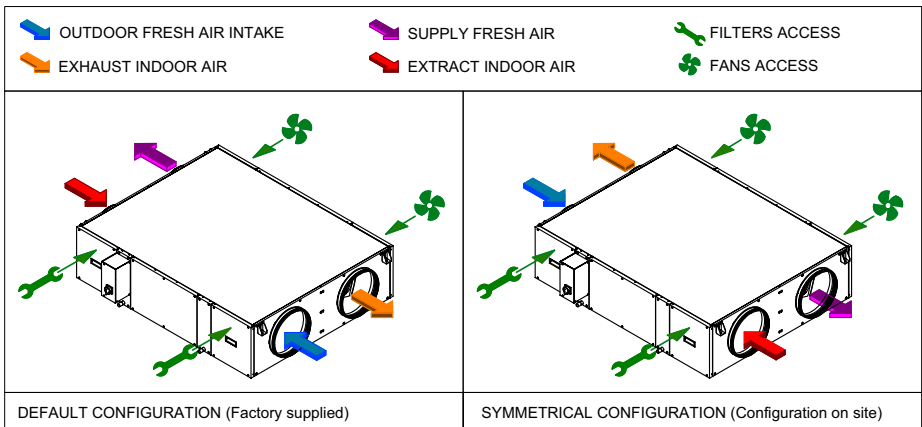

To carry on this modification it is necessary to make the following modifications to the unit:

1. Exchange the supply and extract filters as well as the access covers to the filters.
2. Replace the labels that identify the function of the air inlet/outlet. To do this, a new set of labels is supplied with the unit.

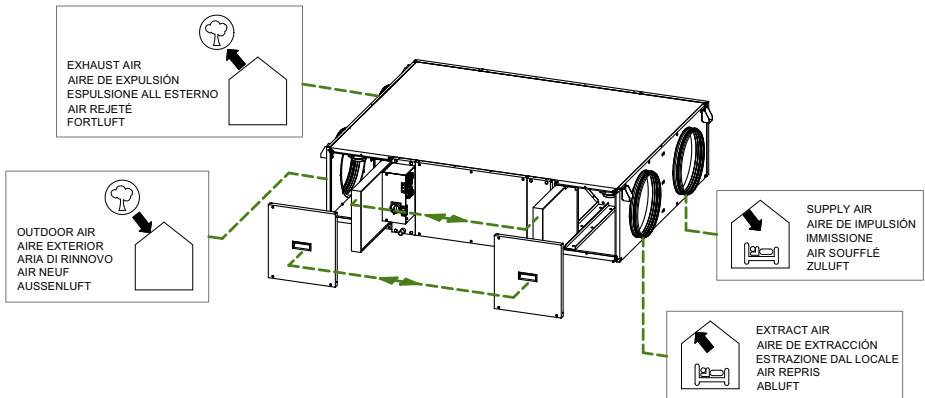

3. Modify the configuration of the controller: Advanced parameters / Installer menu.
4. Only in cold climates where by-pass is used as part of the heat exchanger defrost strategy: Reverse the direction of the by-pass so that it remains at the supply side of the unit.

1. Disconnect the power supply of the heat recovery unit.
2. Remove the heat recovery unit panel (fig.1).
3. Extract carefully the bypass (fig.2).
4. Disconnect the by-pass electrical connector.
5. Turn the bypass according to image (fig.3 and 4).
6. Connect again the electrical connector to the bypass.
7. Place the bypass in its housing again (fig.5), close the panel and start up the unit.

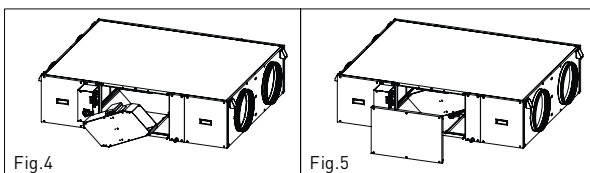
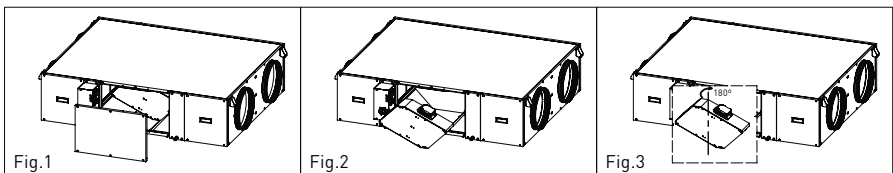

## 7. CONTROL SCHEMES

### CAD-COMPACT ADVANCED

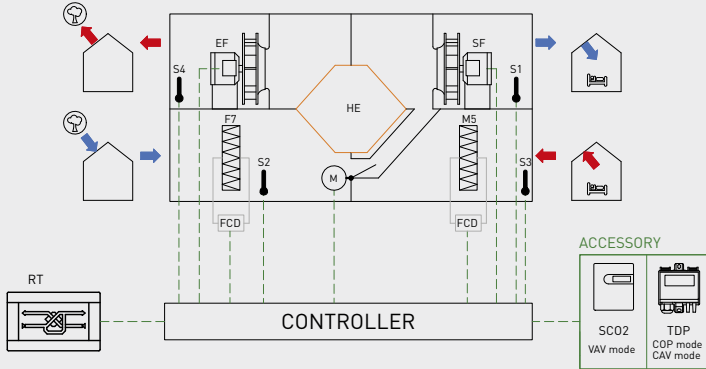

SF	Supply fan	HE	High-efficiency heat exchanger
EF	Extraction fan	RT	Remote control panel
S1	Supply temperature probe	F7	Supply filter
S2	Outdoor temperature probe	M5	Extraction filter
S3	Extraction temperature probe	M	Bypass actuator
S4	Exhaust temperature probe	SC02	CO <sub>2</sub> sensor (accessory)
FCD	Filter clogging detector (Pressure switch)	TDP	TDP-S pressure transmitter (accessory) For CAV mode, 2 units of TDP-S are required

### CAD-COMPACT ADVANCED + EXTERNAL ELECTRICAL COIL MBE-R

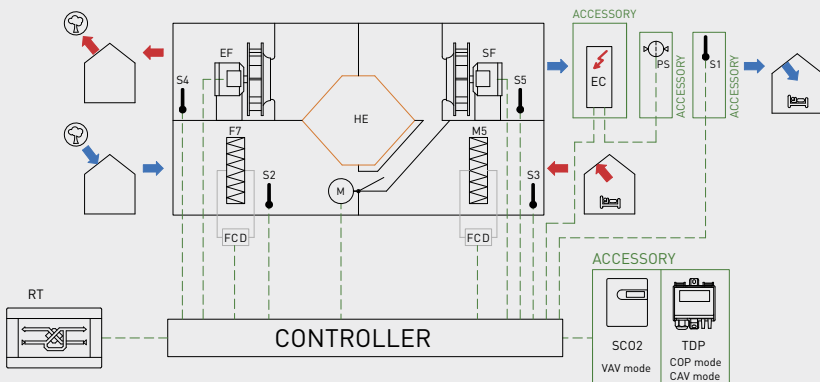

SF	Supply fan	RT	Remote control panel
EF	Extraction fan	F7	Supply filter
S1	Supply temperature probe TG-K-NTC (accessory)	M5	Extraction filter
S2	Outdoor temperature probe	M	Bypass actuator
S3	Extraction temperature probe	EC	External electric coil MBE-R (accessory)
S4	Exhaust temperature probe	PS	Pressure switch DPS 2.30 (accessory)
S5	After-exchanger temperature probe	SC02	CO <sub>2</sub> sensor (accessory)
FCD	Filter clogging detector (Pressure switch)	TDP	TDP-S pressure transmitter (accessory) For CAV mode, 2 units of TDP-S are required
HE	High-efficiency heat exchanger		

### CAD-COMPACT ADVANCED + EXTERNAL HOT WATER COIL BA-AC

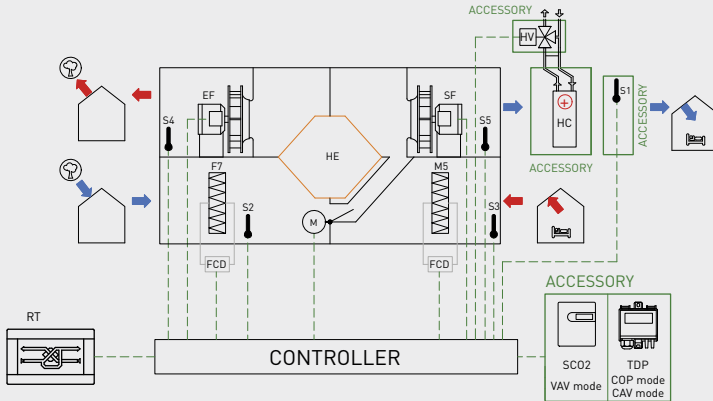

- |     |   |      |   |
|-----|---|------|---|
| SF  | Supply fan                                    | RT   | Remote control panel                        |
| EF  | Extraction fan                                | F7   | Supply filter                               |
| S1  | Supply temperature probe TG-K-NTC (accessory) | M5   | Extraction filter                           |
| S2  | Outdoor temperature probe                     | M    | Bypass actuator                             |
| S3  | Extraction temperature probe                  | HC   | External hot water coil (accessory)         |
| S4  | Exhaust temperature probe                     | HV   | Hot water valve (accessory)                 |
| S5  | After-exchanger temperature probe             | SCO2 | CO <sub>2</sub> sensor (accessory)          |
| FCD | Filter clogging detector (Pressure switch)    | TDP  | TDP-S pressure transmitter (accessory)      |
| HE  | High-efficiency heat exchanger                |      | For CAV mode, 2 units of TDP-S are required |

### CAD-COMPACT ADVANCED + EXTERNAL COLD WATER COIL BA-AF

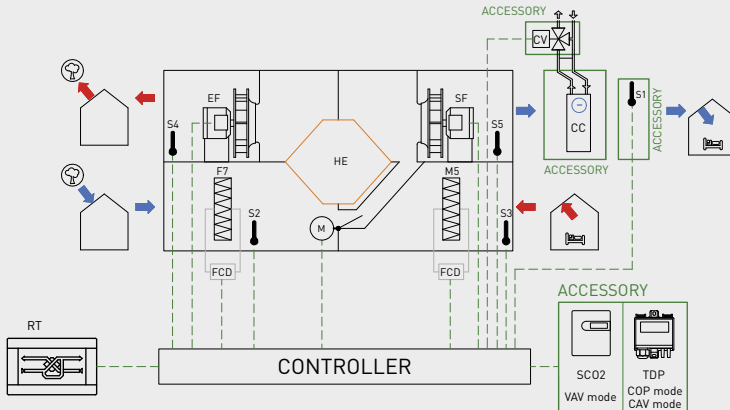

- |     |   |      |   |
|-----|---|------|---|
| F   | Supply fan                                    | RT   | Remote control panel                        |
| EF  | Extraction fan                                | F7   | Supply filter                               |
| S1  | Supply temperature probe TG-K-NTC (accessory) | M5   | Extraction filter                           |
| S2  | Outdoor temperature probe                     | M    | Bypass actuator                             |
| S3  | Extraction temperature probe                  | CC   | External cold water coil (accessory)        |
| S4  | Exhaust temperature probe                     | CV   | Cold water valve (accessory)                |
| S5  | After-exchanger temperature probe             | SCO2 | CO <sub>2</sub> sensor (accessory)          |
| FCD | Filter clogging detector (Pressure switch)    | TDP  | TDP-S pressure transmitter (accessory)      |
| HE  | High-efficiency heat exchanger                |      | For CAV mode, 2 units of TDP-S are required |

### CAD-COMPACT ADVANCED + EXTERNAL COILS COLD WATER (BA-AF) and HOT WATER (BA-AC)

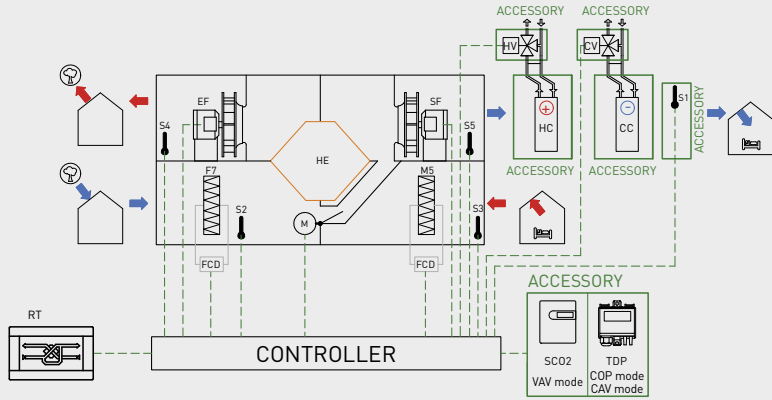

- |     |   |      |   |
|-----|---|------|---|
| SF  | Supply fan                                    | F7   | Supply filter                               |
| EF  | Extraction fan                                | M5   | Extraction filter                           |
| S1  | Supply temperature probe TG-K-NTC (accessory) | M    | Bypass actuator                             |
| S2  | Outdoor temperature probe                     | HC   | External hot water coil (accessory)         |
| S3  | Extraction temperature probe                  | HV   | Hot water valve (accessory)                 |
| S4  | Exhaust temperature probe                     | CC   | External cold water coil (accessory)        |
| S5  | After-exchanger temperature probe             | CV   | Cold water valve (accessory)                |
| FCD | Filter clogging detector (Pressure switch)    | SC02 | CO <sub>2</sub> sensor (accessory)          |
| HE  | High-efficiency heat exchanger                | TDP  | TDP-S pressure transmitter (accessory)      |
| RT  | Remote control panel                          |      | For CAV mode, 2 units of TDP-S are required |

### CAD-COMPACT ADVANCED + EXTERNAL ELECTRIC COIL MBE-R (PREHEATING)

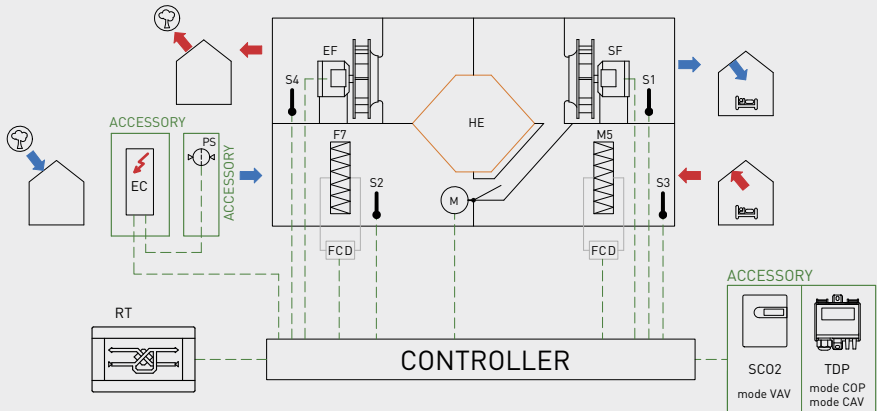

- |     |   |      |   |
|-----|---|------|---|
| SF  | Supply fan                                  | RT   | Remote control panel                        |
| EF  | Extract fan                                 | F7   | Supply filter                               |
| S1  | Supply temperature probe (accessory)        | M5   | Extract filter                              |
| S2  | Outdoor temperature probe                   | M    | Bypass actuator                             |
| S3  | Extract temperature probe                   | EC   | External electric battery MBE-R (accessory) |
| S4  | Exhaust temperature probe                   | PS   | Safety pressure switch DPS 2.30 (accessory) |
| S5  | Pre-battery temperature probe               | SC02 | CO <sub>2</sub> sensor (accessory)          |
| FCD | Polluted filters detector (pressure switch) | TDP  | Pressure sensor TDP-S (accessory)           |
| HE  | Fan Failure Detector (fan relay)            |      | For CAV mode, 2 units of TDP-S are required |

## 8. CONTROL ADVANCED OPERATION

### 8.1. Description

The control ADVANCED is a Plug & Play control factory mounted and wired that allows the management and supervision of heat recovery units of the series CAD-COMPACT.

### 8.2. MAIN FUNCTIONS

The ADVANCED controller allows the management of the following functions:

<b>FUNCTIONS</b>
<b>Fans adjustments</b>
Manual fan speed adjustment, with three pre-set, adjustable speeds.
Automatic fan speed adjustment in VAV mode, based on an external 0-10V signal (CO <sub>2</sub> sensor accessory).
Automatic fan speed adjustment in COP mode (Constant Pressure). The fan speed is adjusted to maintain a constant pressure in the duct network. Applicable to multi-zone installations with motorised dampers. A TDP-S accessory is required.
Automatic fans speed adjustment in CAV mode (Constant Arflow). The fans speed is adjusted to compensate filters fouling. Supply and extract fans independent control allowing the configuration of differents airflow values for each one (2 units of accessory TDP-S are required.)
BOOST function (high-speed timed activation via external volt-free contact).
Automatic fans speed adjustment, according to a configurable time schedule (Configurable Timer).
STOP/START function via external volt-free contact.
<b>Temperature regulation</b>
Display of the temperatures in the touch panel.
Control of the supply temperature by opening the bypass (when the outside temperature allows it).
Regulation of external electric coil MBE-R. Proportional control via 0-10V signal.
Thermal power regulation of external hot water coil. 0-10V to manage 3 ways valve (accessory).
Thermal power regulation of external cooling coil in cooling mode and reversible mode (cooling and heating).
0-10V to manage 3 ways valve (accessory).
Thermal power regulation of 2 external coils (one for cooling and one for heating).
0-10V to manage 3 ways valve (accessories).
<b>Bypass adjustment</b>
Manual operation of bypass.
Automatic operation of bypass free-cooling function.
Automatic operation of bypass as part of the heat exchanger defrost strategy.
<b>SECURITY FUNCTIONS</b>
Control of clogged filters via pressure switches (included).
Alarm display in remote control.
Fan failure detection.
Temperature probes failure detector.
Fire alarm function. Activation of a predetermined behaviour of supply and extract fans after receive the input by an external contact.



## COMMUNICATION

- Wired remote control (10m cable included).
- ON/OFF remote digital input via external volt-free contact.
- Digital input for BOOST function (High speed timed activation).
- Digital input available for connection to fire central.
- ALARM digital output.
- Fans status (Run/Stop) digital output.
- Can be integrated into the BMS - Modbus RTU (RS-485).

### 8.3. USE OF REMOTE TERMINAL - USER LEVEL

The ADVANCED control has a remote control panel (wired) that allows to supervise the operation of the control as well as to configure the working modes of the unit.

The remote terminal is of the touch type so navigation is done by tapping on its screen.

#### 8.3.1. Navigation

The main screen shows general information about the unit operation in two different ways of visualization: List of variables and graphic representation. To move from one type of visualization to the other, press the following icons:

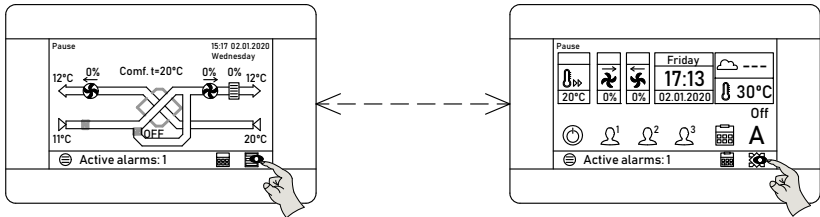

Information displayed in the "Data list" view:

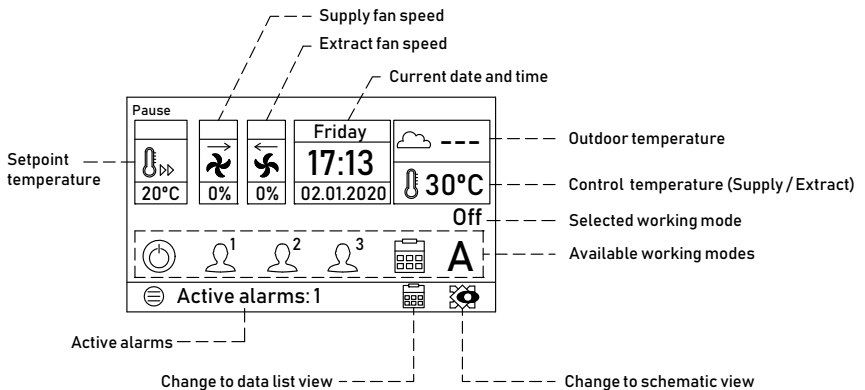



Information displayed in the “Schematic representation” view:

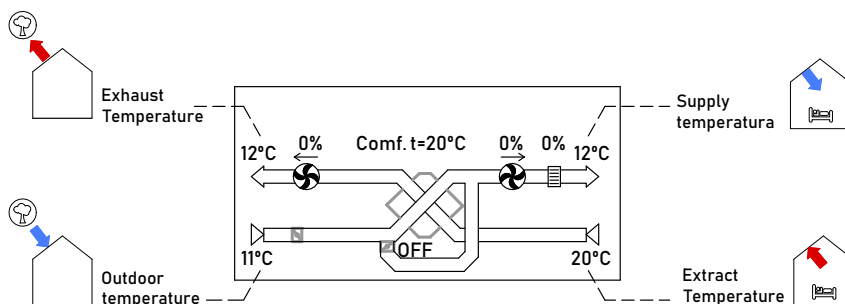
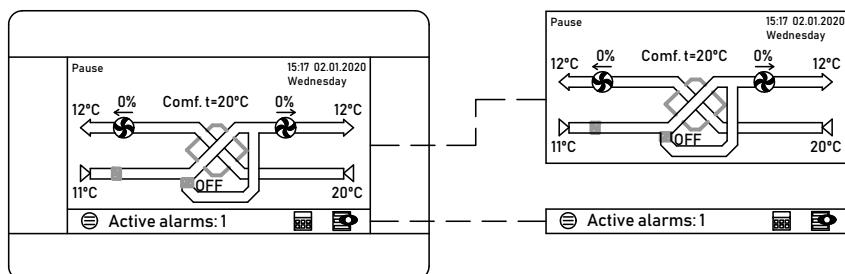

### 8.3.2. Access levels

There are 3 levels of access:

- **User:** Access to the parameters that a user may need. It allows making basic adjustments such as changing the fan speed or the temperature set point, as well as selecting the unit’s operating mode (Use of time programming, remote stop the unit or possibly forcing a specific speed). No password is required.
- **Installer:** In addition to the functions and parameters accessible at the user level, it allows access to the configuration of advanced functions, such as setting a fan operating mode (COP, VAV, CAV), activating the automatic mode commanded by a signal from a CO<sub>2</sub> sensor, modifying the fan configuration, the bypass configuration, the boost function or the fire alarm function, interchange the supply and extract fans functions (symmetry). Requires entering password, by default 1111.
- **Producer:** In addition to the functions and parameters accessible in the user and installer menu, it allows access to the configuration of additional functions related to the external coils management (accessories). Requires entering password, by default 1951.

### 8.3.3. Quick access functions

From either the data list view it is possible to make direct access to the functions of “Fan speed adjusting” and “Changing the set temperature”. The access is done through the following indicated icons:

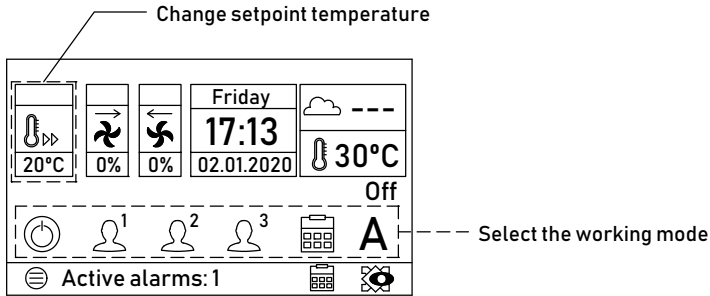

### 8.3.3.1. Fan speed adjustment

In the bottom zone of the screen, 6 icons allow to select the desired fan speed:

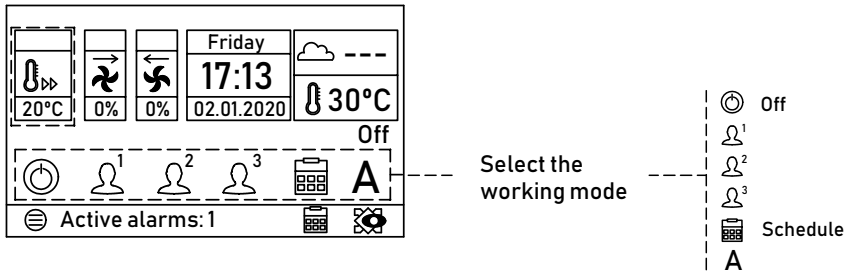

Modification of the value is made by pressing directly in the icon:

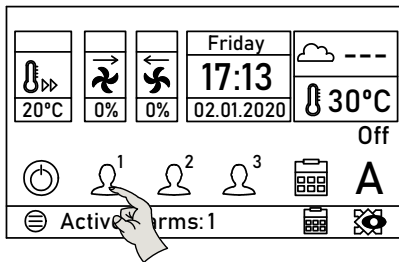

Once the speed has been selected, the icon shows remarked in a circle:



By pressing the calendar icon in the bottom part of the display, it is possible to access the time schedule configuration (See specific chapter TIME SCHEDULE):

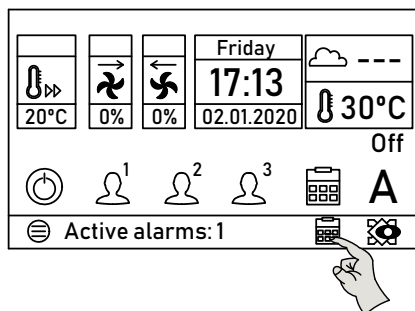

### 8.3.3.2. Set temperature setting

Pressing the SET POINT TEMPERATURE button will open a window indicating the current value of the set temperature. Modification of the value is made with the + or - buttons. Once modified, exit by pressing CONFIRM AND EXIT:

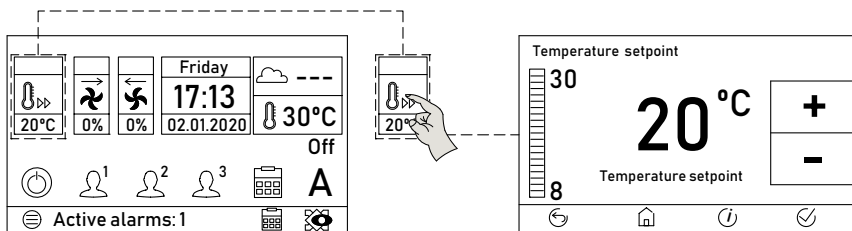

- +** Increase temperature
- Decrease temperature
- ✓ Confirm and exit
- ⌂ Exit
- 🏠 Back to main screen
- ℹ Information about the function

### 8.3.4. Main menu



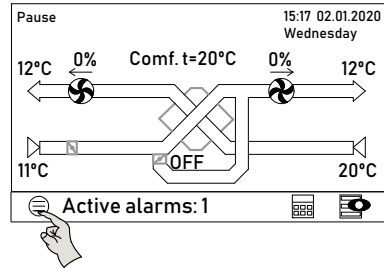
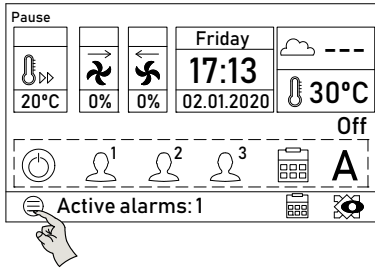

Access to the main operating parameters of the equipment is done from the "main menu", which is accessed by pressing on the MENU button from any of both views:

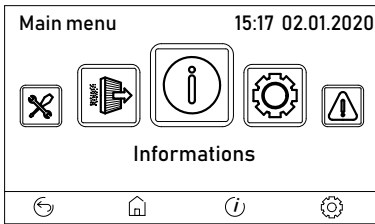

From this menu it is possible to read / configure the following information:



Submenu	Function	
 Information	<b>Information (only read) of the following functional variables</b>	
	<b>Parameter</b>	<b>Description</b>
	Temperatures	Air temperatures
	Fans control	Fans state
	Filters	Filters state
	Work status	Post heater state / cooling (in case of existing)
	Work state	Fans working mode
	Byp./P.-cool	By-pass state
	Boost mode	Boost function state (High speed)
	Digital inputs	Digital inputs state
	Heat recovery	Current heat recovery efficiency
	Air qual. transducer	Level of CO <sub>2</sub> (In case of existing)
	Operation hours	Working hours counter
	Software versions	Controller and remote control (panel) software versions
ecoNET LAN	Not used	
ecoNET WiFi	Not used	
WiFi status	Not used	

Submenu	Function	
 General settings	<b>Heat recovery unit elemental configuration</b>	
	<b>Parameter</b>	<b>Description</b>
	Button pressing sound	Activate or deactivate the “beep” sound each time one of the icons-buttons on the remote is pressed
	Alarm volume	Set the volume of the acoustic alarm signal
	Alarm sounds	Enable or disable the acoustic signal when an alarm occurs
	Screensaver settings - Delay -	Define the inactivity time before activating the screensaver
	Screensaver settings - Mode -	Screensaver settings. Allows to enable a screensaver: OFF: No screensaver ON: Activates a screensaver consisting of blanking the screen after a period of inactivity Clock on display: Activates a screensaver that contains time, date, control temperature and unit status. The screensaver only appears when the controller is on the main screens. It is not activated from the configuration menus
	ecoNET settings	Not used
	HMI panel address	Communication address of the HMI panel (This parameter must remain at 100. Do not modify)
	Brightness	Adjust screen brightness
	Contrast	Adjust screen contrast
	Language	Change language
	Date and clock	Set the current date and time
	Default settings	Load default parameters (Do not manipulate)
	Panel SW update	Update the remote panel software
Controller SW update	Update the controller software	
 Alarms	<b>Show active alarms</b>	
 Time schedule	<b>Time programmer configuration</b> See specific chapter on the use of this function	
 Service settings	<b>Access to advanced parameters</b> See specific chapter on the use of this function	
 Filt. Work met. erase	<b>Reset the hour counter since filter change</b> Must be done after every filter change	

### 8.3.5. Information menu

Through this menu it is possible to have access to a large number of functional parameters of the equipment that allow to know the functional situation of the equipment (Temperatures, status of the inputs and outputs of the controller, operating hours, etc.)

All this information is read-only, it is not possible to modify any of the settings.  
Exploded view of the Information submenu navigation:

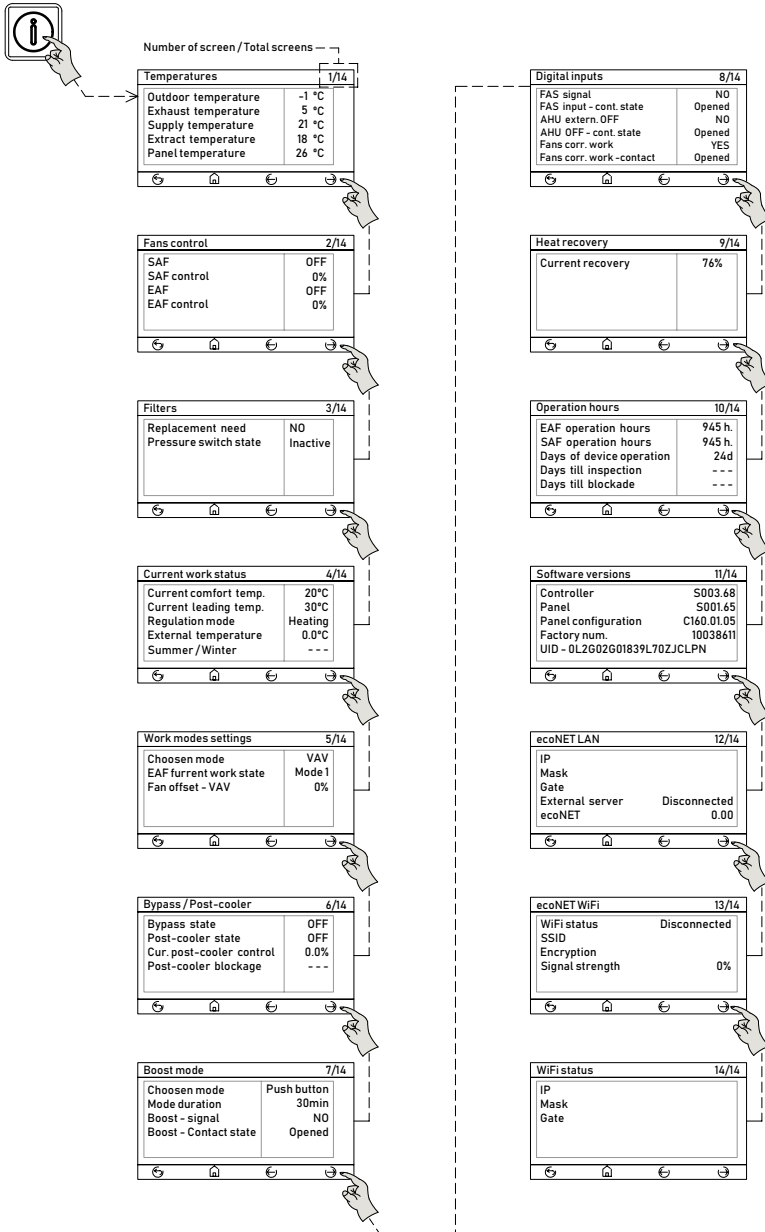

## 8.4. UNIT CONFIGURATION

Access to the General Settings menu parameters:

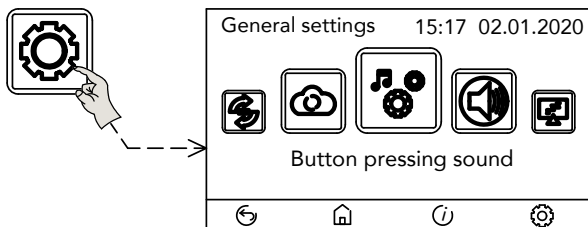

### 8.4.1. Change the idiom

From factory the controller is configured in Spanish language. From the General Settings menu, access the Language button and select the desired idiom:

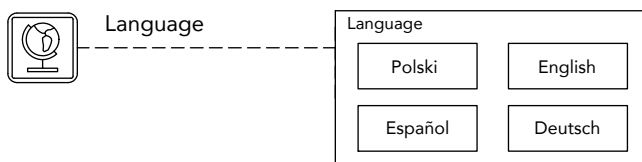

### 8.4.2. Setting the system date / time

Allows to set the current date and time. It is important that both are well configured to have information in the alarm history and adjust the hourly timing appropriately.

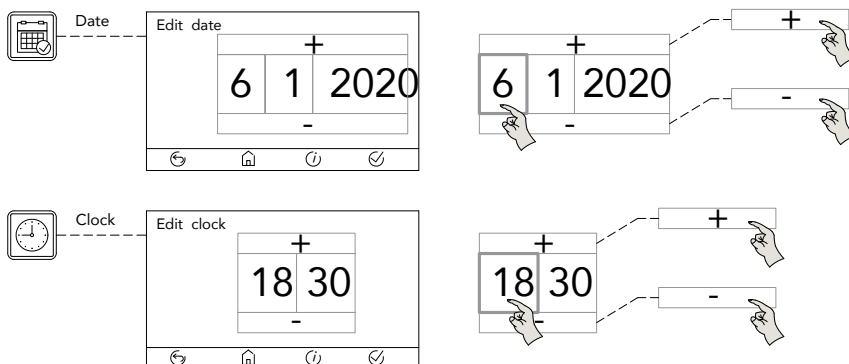

### 8.4.3. Image and sound settings

From the general setting menu it is possible to modify the default settings related to acoustic signals and the screen display:



Modify or cancel the sound volume when pressing the button:

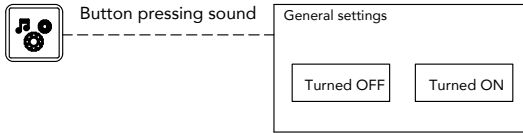

Modify or cancel the sound volume when an alarm is activated:

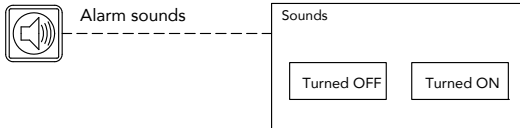

Adjust the display brightness:

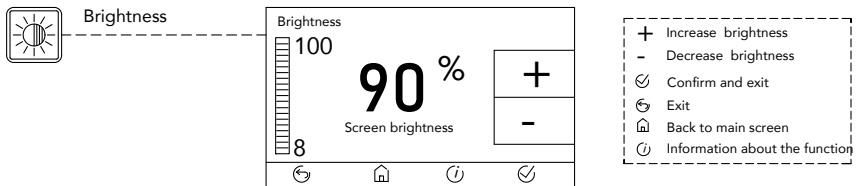

Activate a screensaver to be shown after a time of non-activity:

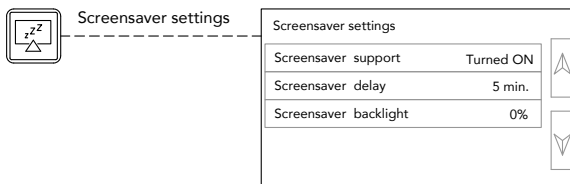

#### 8.4.4. Time schedule

The controller has an internal time programmer that allows setting the working hours at different speeds (3 predefined speeds, automatic operation or stop of the fans).

The access to the time schedule specific screen can be done from the icons in the bottom part of the main display and from the main menu icon:



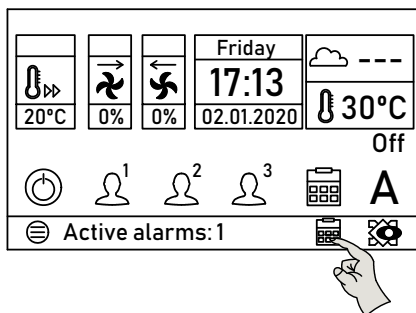

And from the main menu icon:

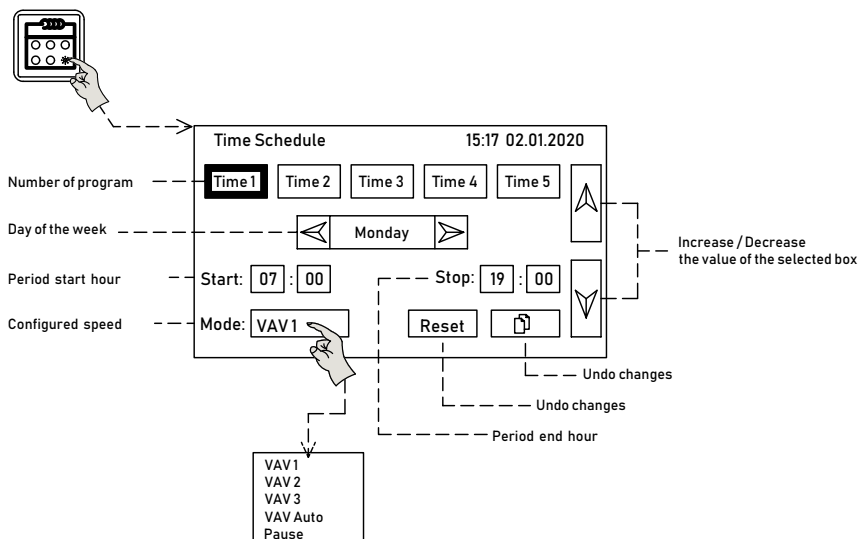

### Scheduler settings:

The programmer works by time intervals. For each day, it is possible to configure 5 different intervals/programs (T1 to T5). By default, the unit is supplied without any preconfigured program (in the time and date boxes it appears -1 indicating that the box value is empty).

To create a new interval/program, follow the following sequence:

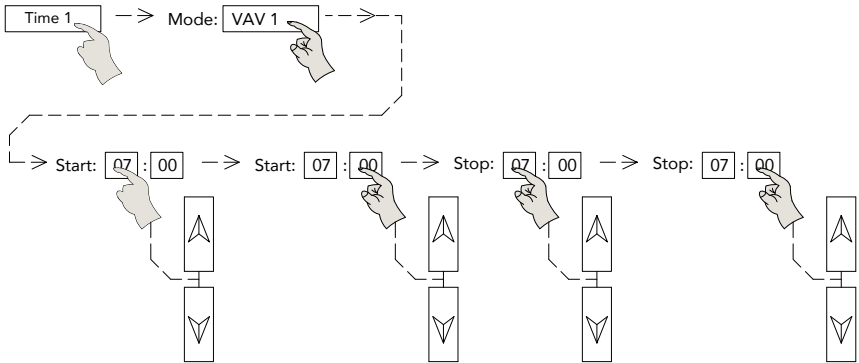

Once a schedule has been created for a particular day (T1 to T5), it is possible to copy the same schedule to other days:

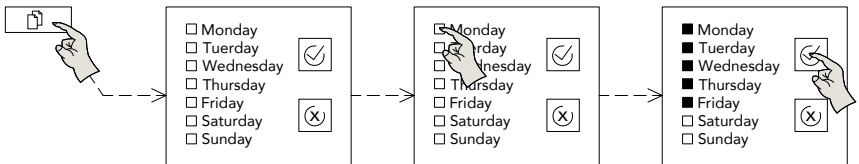

Example of time programming:

- Monday to Thursday:  
From 8:00 to 13:00 and from 15:00 to 19:00 in AUTO  
With high speed sweep from 13:00 to 15:00
- Friday:  
From 8:00 to 16:00 in AUTO

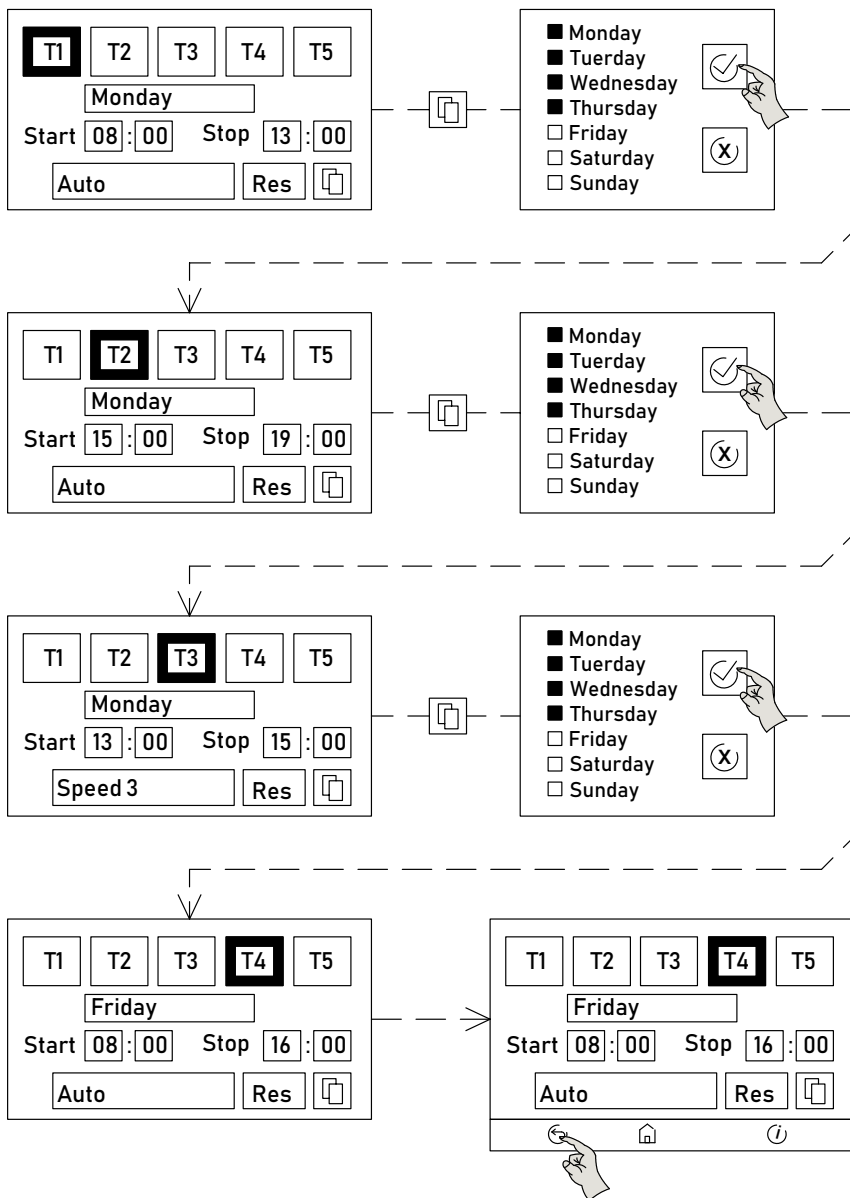

### 8.4.5. Unit configuration – installer parameters

The configuration of the advanced parameters requires identification by password. The default password is 1111.

Access to advanced parameters from the main menu:

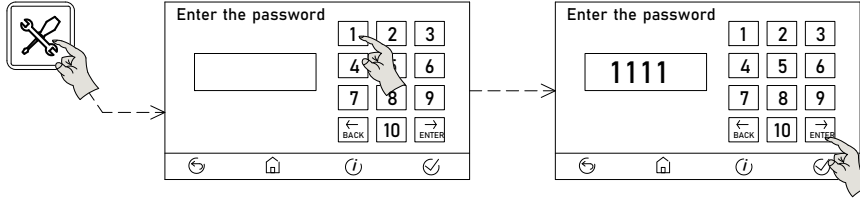

Content of the functions and parameters accessible from the advanced parameters / Installer menu:

**IMPORTANT: Most of the parameters contained in this menu should not be modified by the installer or user. Its configuration has been made at the factory and its modification could lead to a malfunction of the unit. Limit yourself to setting only those parameters related to the equipment's working mode.**

Menu	Function
AHU working mode	Configuration of the working mode of the fans (VAV, COP, CAV) and adjust the parameters associated with each mode <i>See extended information in specific chapter</i>
Temperature	Define the setpoint temperature and the temperature control mode (on supply or exhaust air)
Diff. pressure sensor	Define pressure transmitter settings (in COP and CAV modes) <i>See extended information in specific chapter</i>
Fans settings	Fan related settings: <ul style="list-style-type: none"> <li>- Minimum and maximum speed</li> <li>- Proportional and integral regulation bands</li> <li>- Supply fan stop timing</li> <li>- Minimum outside operating temperature</li> </ul> <i>See extended information in specific chapter</i>
AQS configuration	Sensor type for AUTO mode (CO <sub>2</sub> or humidity)
Bypass	By-pass control mode: <ul style="list-style-type: none"> <li>- Opened manually</li> <li>- Manually closed</li> <li>- Automatic</li> <li>- Freecooling</li> </ul> It allows defining freecooling control parameters such as: <ul style="list-style-type: none"> <li>- Minimum differential between outside and inside temperature for the by-pass to activate</li> <li>- Minimum outside temperature below which the by-pass is not activated</li> </ul>
Boost mode	Settings related to Boost mode such as: <ul style="list-style-type: none"> <li>- Activation type: Push button or switch</li> <li>- Fan speed in Boost mode</li> <li>- Boost duration</li> <li>- Trigger digital signal type (NO / NC)</li> </ul>

Menu	Function
Filter settings	<b>DO NOT MODIFY THIS PARAMETER</b> Type of digital signal used for detection and timing in alarm activation: Normally open
Fire alarm system	Activation of fire mode and its configuration: – Type of activation signal (NO, NC) – Status of the supply and extraction fans during fire mode (Stop / Run) – Speed of the supply and extraction fans during fire mode (0-100%)
Burglar Alarm System	Not used
Exchanger antifreeze	<b>DO NOT MODIFY THIS PARAMETER</b> Settings related to heat exchanger antifreeze protection: – Fan speed in antifreeze mode – Enable the control of a preheating battery
Supply temp. prot.	<b>DO NOT MODIFY THIS PARAMETER</b> Post-heating control configuration. If there is an external battery as an accessory
Alarms erase	Clear alarm history
Inspection	Set an alarm associated with preventive maintenance (Appears after X days from the activation of the function)
Default settings	<b>DO NOT MODIFY THIS PARAMETER</b> Reset factory settings
Modbus settings	Modify the Modbus communication parameters, depending on the needs of the existing Modbus network (Id, transmission speed, stop bits, parity, etc.)
Exchanger cleaning	Not used
Channel config.	Allows you to reverse the function of the supply and extraction fans <i>See extended information in specific chapter</i>

#### 8.4.6. Fans working modes

The unit fans can operate according to 3 operating modes:

- VAV: Variable airflow. The speed of the fans can be defined manually or in automatic mode depending on an external sensor supplied as accessory (Air quality, humidity or similar)
- COP: Constant pressure. A pressure transmitter with 0-10V output signal is required installed in the ductwork on which the pressure is to be controlled (Supplied as an accessory)
- CAV: Constant airflow. Two pressure transmitters with 0-10V output signal are required installed in the specific pressure taps available on the unit. (Supplied as an accessory)



To define the fans working mode, access the installer menu and choose the working mode:

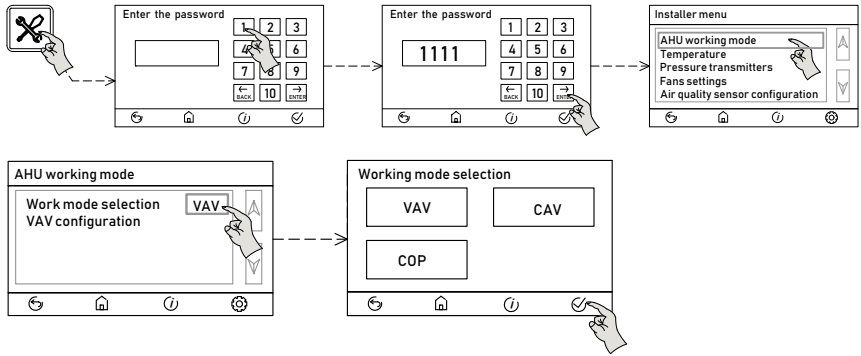

Once the desired mode is selected, exit by pressing the “Confirm and exit” button. Depending on the selected mode, it is possible to define the parameters associated to each work mode:

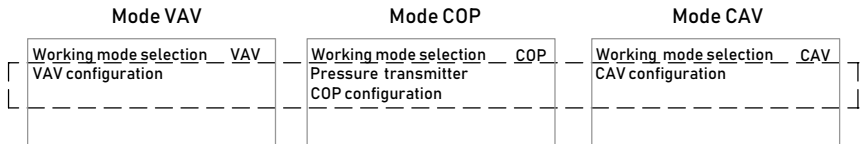

### 8.4.6.1. Variable flow operation (VAV)

Recommended mode in single zone installations for operation at predefined speeds or variable flow based on a 0-10V type signal.

#### VAV Manual: Run at preset speeds

Assignment of speeds:

Follow the procedure below for the 3 preset speeds:

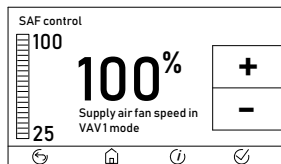
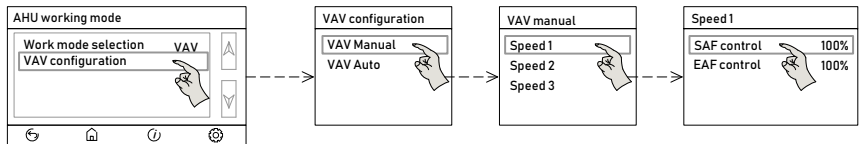

- + Increase speed
- Decrease speed
- ☑ Confirm and exit
- ⌂ Exit
- 🏠 Back to main screen
- ℹ Information about the function

### Automatic VAV mode operation

The fan speed is adjusted according to the value measured by an external 0-10 V probe (CO<sub>2</sub> sensor, temperature or relative humidity).

Before configuring the sensor, it is necessary to enable the Indoor Air Quality function and select the type of external sensor CO<sub>2</sub> or humidity:

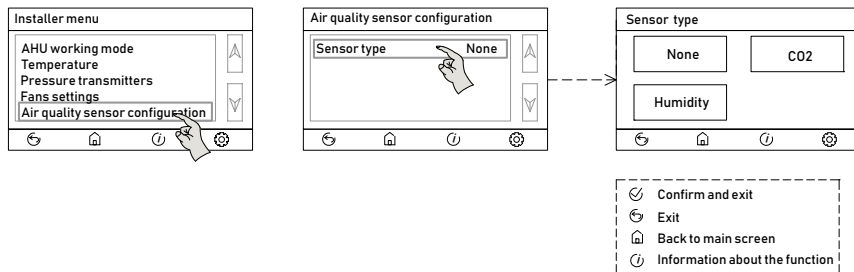

### Setting the Automatic VAV mode

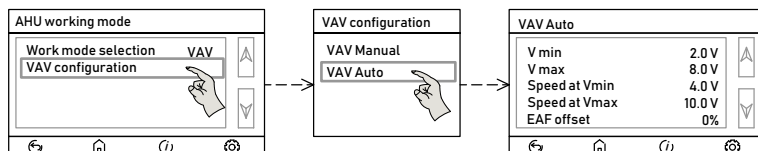

These settings allow to define the fans regulation ramp, this is the relation between the input received from the external sensor and the regulation output to the fans.

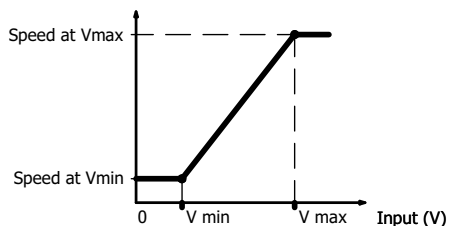

The way to modify the values of each settings is the same for all cases.

Example of configuration of the proportional ramp with sensor 0-2000 ppm to achieve:

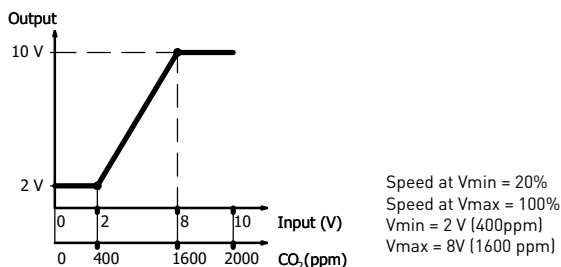

The “Slave fan offset” parameter allows defining the ratio between the supply and extraction fan speeds. It is entered as a percentage between supply and extraction fan speed (+/- 50%).

#### 8.4.6.2. Constant pressure operation (COP)

Recommended mode in multi-zone installations, in which the flow rate regulation per zone is carried out by dampers. The fan speed is automatically adjusted to maintain a constant pressure in the ductwork measured by an external pressure transmitter (supplied as an accessory).

To select COP mode follow the sequence:

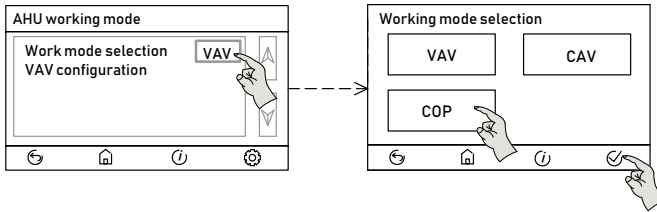

Once selected, define the duct circuit in which the pressure transmitter is installed (Supply or extraction):

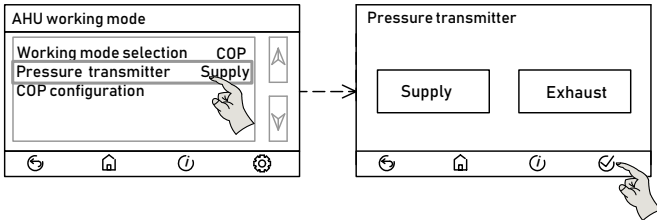

And configure the value of the pressure setpoint:

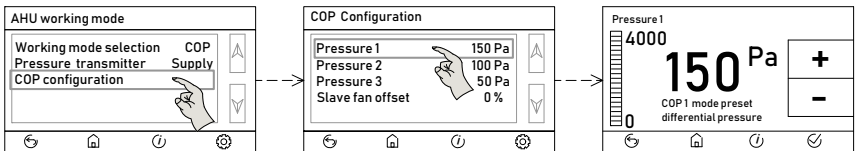

- + Increase pressure
- Decrease pressure
- ✓ Confirm and exit
- ⌂ Exit
- ⌂ Back to main screen
- ℹ Information about the function

After this, configure the pressure transmitters, making sure that the data entered matches the specifications of the pressure transmitter that is being used:



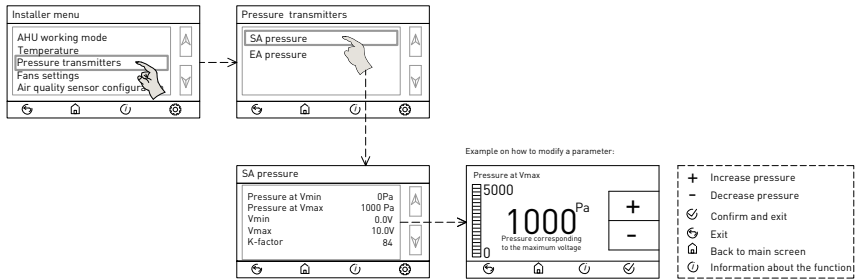

### 8.4.6.3. Constant flow operation (CAV)

Recommended mode in those installations where it is necessary to maintain a constant airflow. The speed of the fans is regulated to achieve a previously defined airflow and keep it constant.

**The control of each fan is independent. The supply fan airflow (SAF) and the extract fan airflow (EAF) are controlled by their respective pressure transmitters.**

To select CAV mode follow the sequence:

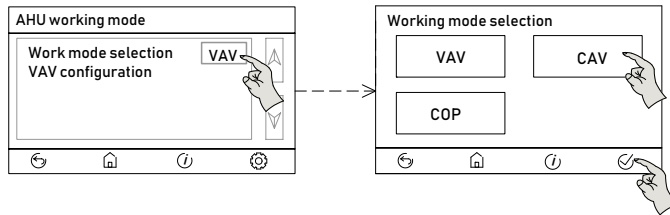

Once selected, configure the value of the airflow setpoint:

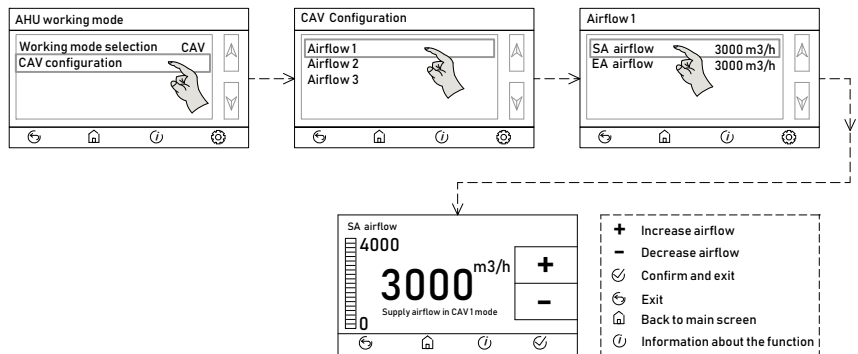

It is necessary to specify the pressure range of the flow transmitter that have been used as well as the K-factor of the fan, following the following sequence:

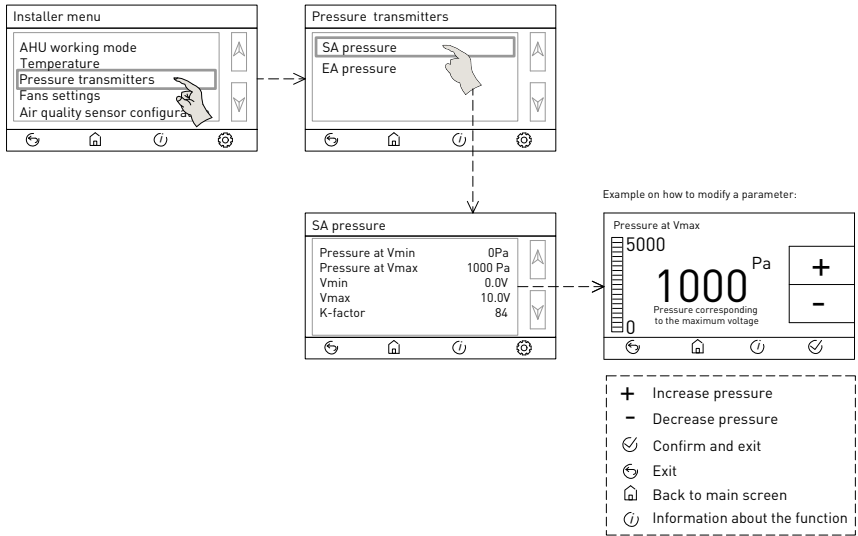

Follow the sequence used to modify the Pressure at Vmax to modify the rest of parameters.

Parameter	Definition
Pressure at Vmin	Lower value of pressure transmitter range Example: 0Pa in case of transmitter with range 0-500 Pa
Pressure at Vmax	Upper value of pressure transmitter range Example: 500Pa in case of transmitter with range 0-500 Pa
Vmin	Lower value of the pressure transmitter output voltage Example: 0V in case of transmitter with 0-10V output
Vmax	Lower value of the pressure transmitter output voltage Example: 10V in case of transmitter with 0-10V output
K-factor	Fan form factor, by which the differential pressure value is converted into flow. Depends on the model

Enter the K-factor value depending on the heat recovery unit model:

Model	K-factor
CAD-COMPACT 500	28
CAD-COMPACT 900	59
CAD-COMPACT 1300	55
CAD-COMPACT 1800	58
CAD-COMPACT 2500	120
CAD-COMPACT 3200	93
CAD-COMPACT 4500	177

## 8.4.7. Regulated output settings

Depending on the characteristics of the duct network (length and diameter) and the regulation elements (type of dampers and opening / closing times), it may be necessary to modify the settings of the fan regulation signal (Maximum and minimum speed, proportional band or integral band among others). Access to the output regulation parameters is done from the Installer menu:

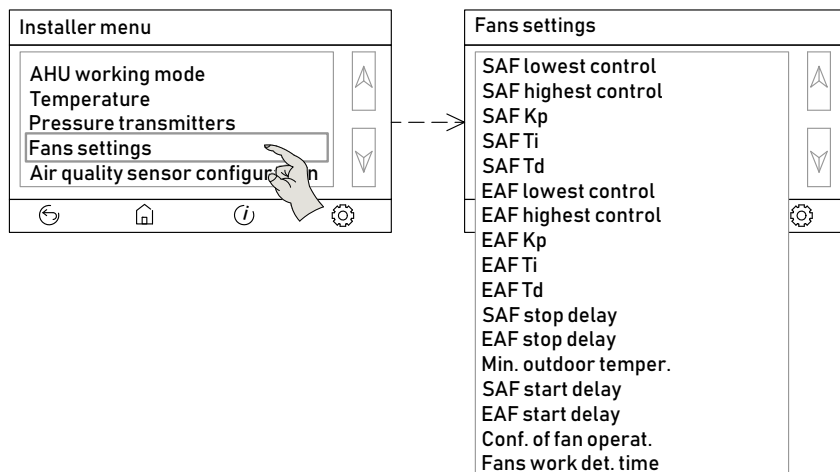

Parameter	Function
SAF lowest control	Supply fan minimum speed (% on Maximum Speed)
SAF highest control	Supply fan maximum speed (% on Maximum Speed)
SAF Kp	Proportional constant for the supply fan regulation output. Default value = 3. Modify according to indications in the next table
SAF Ti	Integral constant for the supply fan regulation output. Default value = 160. Modify according to indications in the next table
SAF Td	Derivative constant for the supply fan regulation output. Default value = 0. Do not modify this parameter
EAF lowest control	Extract fan minimum speed (% on Maximum Speed)
EAF highest control	Extract fan maximum speed (% on Maximum Speed)
EAF Kp	Proportional constant for the extract fan regulation output. Default value = 3. Modify according to indications in the next table
EAF Ti	Integral constant for the extract fan regulation output. Default value = 160. Modify according to indications in the next table
EAF Td	Derivative constant for the extract fan regulation output. Default value = 0. Do not modify this parameter
SAF stop delay	Supply fan stop delay
EAF stop delay	Extract fan stop delay
Min. outdoor temper.	Option to configure an automatic shutdown of the equipment when the outside temperature drops below a certain temperature



Parameter	Function
SAF start delay	Supply fan start delay
EAF start delay	Extract fan start delay
Conf. Of fan operat.	Configuration of the digital output contact (NC or NO) that informs about the fan status
Fans work det. time	Timing before checking fan failure

If it is necessary to modify the response of the regulated signal, follow the following instructions:

Regulation problem	Behavior	Settings
Unstable regulation	Cannot maintain a stable airflow and the fan speed increases and decreases periodically	Reduce EAF Kp and SAF Kp Increase integral time EAF Ti and SAF Ti
Slow regulation	Although the fans are not at their maximum speed, their speed increase too slowly	Increase EAF Kp and SAF Kp Decrease integral time EAF Ti and SAF Ti

#### 8.4.8. Filter supervision

CAD-COMPACT ADVANCED heat recovery units are supplied with pressure switches mounted on both filters (supply and extraction). When the differential pressure value measured by the pressure switches exceeds 200Pa an alarm is produced. Depending on the particularities of the installation (operating hours and pollution of the outdoor environment) it may be advisable to change the pressure switch setting as indicated in the following table:

Filters state	Airflow	Action
The filters alarm appears often	When the dirty filter alarm is active, the airflow is correct	Increase pressure switch setting to 300 Pa
No dirty filter alarm appears or it takes too long to appear.	Insufficient airflow due to filter clogging	Reduce the pressure switch setting to less than 200Pa
The filters alarm appears with too much frequency	When the dirty filter alarm is active, the airflow is insufficient	The performance of the heat recovery unit is not enough: - Review the dimensioning of the duct system - Check leakages - Oversize the selected heat recovery unit

To change the pressure switch setting, follow the sequence below:

1. Access the filter zone in which the pressure switch filters are placed

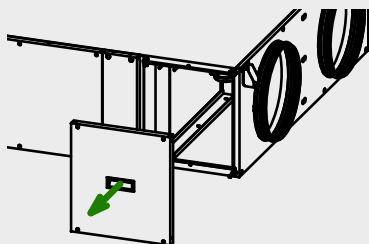

2. Lift the pressure switch cover

lift slightly and remove the disassembly the cover from the base

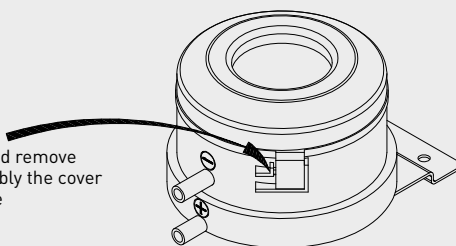

3. Turn the dial (1) using a flathead screwdriver, until the pointer (2) indicates the pressure value to be defined

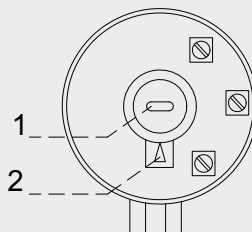

### 8.4.9. Exchange the function of the supply and extraction circuits

By modification of the controller settings (Advanced parameters / Installer menu) it is possible to interchange the function of the supply and extract fans. The supply fan becomes the extraction fan and viceversa.

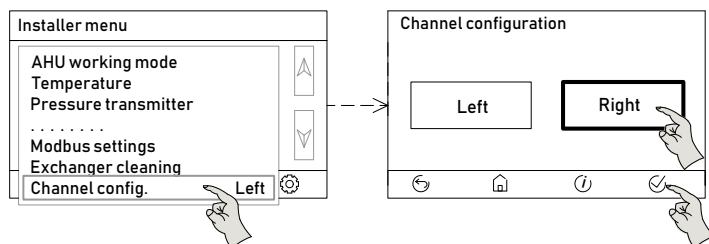

**TOP VIEW**

Supply air fan at left side (by default)

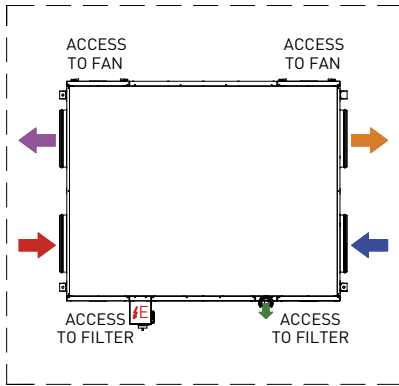

**TOP VIEW**

Supply air fan at right side

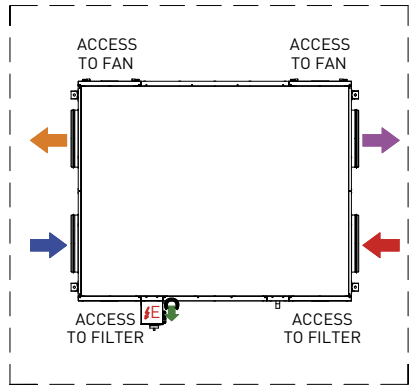

	ELECTRICAL CABINET		SUPPLY NEW AIR		EXHAUST INDOOR AIR
	OUTDOOR AIR INTAKE		EXTRACT INDOOR AIR		CONDENSATED OUTLET 1/2"

**8.4.10. Boost function**

By closing an external digital contact, it is possible to force the fan operation at high speed for a settled time.

**Operation:** when activating the boost mode on terminals DIN1 (IN and GND), fans start running at Boost speed. The unit will stay at that speed during the preset time (30 minutes by default). After this time the fans go back to its previously selected speed. By means of the corresponding advance parameters it is possible to configure the boost parameters:

- Type of activation signal:
  - *Push button*: The unit will work at the configured speed during the Boost time.
  - *Switch*: the unit will work at the configured speed as long as the switch is activated.
- Duration of boost time (just when activation mode is done by push button).
- Type of contact (NO, NC)

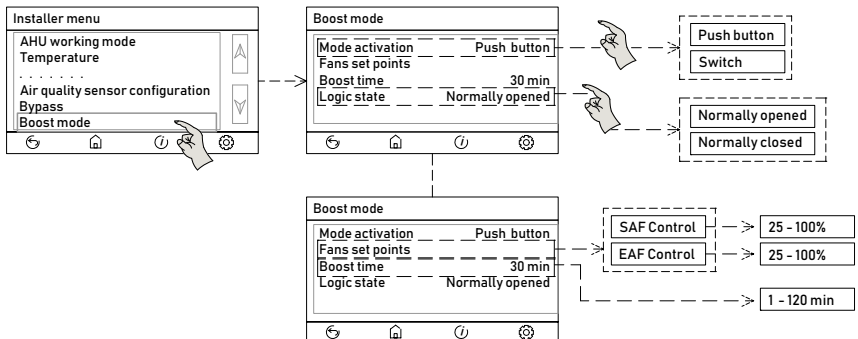

### 8.4.11. Remote Stop-Start

It is possible to start-stop the unit by means of an external digital contact (see electric diagrams). The contact closure between DIN5 (Terminals IN and GND), will produce the unit stop.



**When the equipment is stopped remotely the control hand terminal displays an alarm message, warning that it is possible that the unit will be start up from remote suddenly.**

### 8.4.12. Protection of heat exchanger unit

This functionality prevents freezing of the condensates existing inside the heat exchanger (on the side of the exhaust air).

In order to protect the heat exchanger, the ADVANCED controller implemented 3 different strategies:

Function	Strategy
Pre-heater activation	<ul style="list-style-type: none"> <li>In case of pre-heater installed in the outdoor air intake (accessory), the controller will activate the heater. See specific requirements in the specific chapter about the requirements and warning in case of pre-heating coil addition.</li> </ul>
Fans unbalancing	<ul style="list-style-type: none"> <li>It is activated when the exhaust air temperature descends <b>3°C</b>. The unit comes into Defrost mode, setting the supply fan SAF at <b>35%</b> of its nominal speed, while the extract fan EAF remains at his nominal speed.</li> </ul>
By-pass opening	<ul style="list-style-type: none"> <li>It is activated when the exhaust air temperature descends <b>1°C</b>. At that moment the by-pass damper opens, diverting the supply air directly into the building and using the exhaust air to defrost the heat exchanger.</li> </ul>
Supply air temperature supervision	<ul style="list-style-type: none"> <li>Regardless of the protection strategies activated, if the supply air temperature falls below <b>11°C</b>, after a time delay of <b>5 mins</b> the unit will stop, restart again after <b>1 hour</b>.</li> <li>These parameters are configurable.</li> </ul>

## 9. FIRE FUNCTION (FIRE)

It is possible to assign a digital input to the FIRE function. After receiving the signal from an external fire control unit, it will be forced a predetermined behavior of the heat recovery unit fans.

Input signal type: Potential free (contact closed = Alarm).

It is possible to assign the following behaviors:

#### Fire alarm strategy by default:

- Force the Supply fan runs at maximum speed.
- Force the Extract fan stop.

The fire alarm strategy can be modified, adapting the unit behaviour to the local regulations. To modify them is necessary to access the Fire alarm menu:

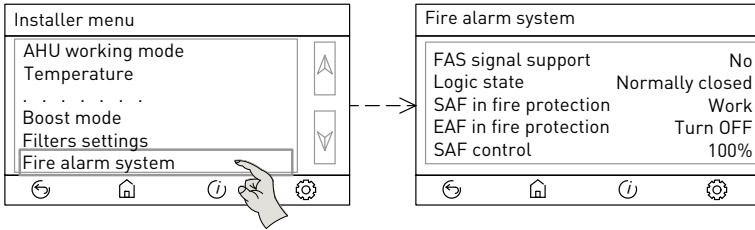

## 10. CONTROL OF EXTERNAL COILS AND BATTERIES (HEATING / COOLING)

The CAD-COMPACT ADVANCED units are complemented by a complete range of air treatment accessories consisting of:

- Electric pre-heating coil
- Post-heating electric coil
- Post-heating hot water coil
- Post-cooling cold water coil

**The ADVANCED control has only 2 regulated outputs available to control external batteries. These outputs must be reconfigured according to the needs:**

- **Pre-heater + Post-heater**
- **Post-heater + Post-cooler**
- **Pre-heater + Post-cooler**

To carry out the control of external batteries it is necessary to acquire some external accessories such as batteries, probes, valves.

List of necessary accessories depending on the type of battery to be controlled:

### External water post heating coils

Model	Control of an external hot water coil			Control of an external cold water coil**		
	Supply temperature control sensor	Hot water coil	Valve	Supply temperature control sensor	Hot/cold water coil	Valve
CAD-COMPACT 500 ADVANCED	TG-K-NTC	BA-AC-N 200	3WV DN 15 KVS1 PROP 24V	TG-K-NTC	BA-AF 200	3WV DN15 KVS1 PROP 24V
CAD-COMPACT 900 ADVANCED	TG-K-NTC	BA-AC-N 315	3WV DN 15 KVS1,6 PROP 24V	TG-K-NTC	BA-AF 315	3WV DN15 KVS1,6 PROP 24V
CAD-COMPACT 1300 ADVANCED	TG-K-NTC	BA-AC-N 315	3WV DN 15 KVS2,5 PROP 24V	TG-K-NTC	BA-AF 315	3WV DN15 KVS2,5 PROP 24V
CAD-COMPACT 1800 ADVANCED	TG-K-NTC	BA-AC-N 355/18	3WV DN 15 KVS2,5 PROP 24V	TG-K-NTC	BA-AF 355/18	3WV DN20 KVS4 PROP 24V
CAD-COMPACT 2500 ADVANCED	TG-K-NTC	BA-AC-N 400*	3WV DN20 KVS4 PROP 24V	TG-K-NTC	BA-AF 400*	3WV DN25 KVS10 PROP 24V
CAD-COMPACT 3200 ADVANCED	TG-K-NTC	BA-AC-N 400*	3WV DN20 KVS4 PROP 24V	TG-K-NTC	BA-AF 400*	3WV DN25 KVS10 PROP 24V
CAD-COMPACT 4500 ADVANCED	TG-K-NTC	BA-AC-N 450*	3WV DN25 KVS6,3 PROP 24V	TG-K-NTC	BA-AF 450*	3WV DN25 KVS10 PROP 24V

\* In order to use the circular accessories it is necessary to install the corresponding PRRE adapter.

\*\* In the case of cold water coils that are going to be used in reversible mode (cold/heat), it will be necessary to add a COM-2 switch (manual change of mode) or a THCO thermostat (automatic change of mode) to the electrical maneuver, depending on the temperature of the water received).



In the installation of external water coils, the assembly of the module should be done in the way that:

- Air and water flows circulate in counterflow
- Water inlet connection should be in the coil lower part

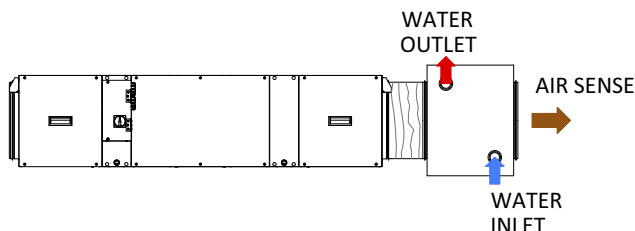

### External electric coils

Model	Control of an external electric coil		
	Regulated electric coil	Duct temperature probe	Differential pressure switch
CAD-COMPACT 500 ADVANCED	MBE-200/20T-R 2/400V	TG-K-NTC	DPS 2.30
CAD-COMPACT 900 ADVANCED	MBE-315/30T-R 2/400V	TG-K-NTC	DPS 2.30
CAD-COMPACT 1300 ADVANCED	MBE-315/30T-R 2/400V	TG-K-NTC	DPS 2.30
CAD-COMPACT 1800 ADVANCED	MBE-355/60T-R 2/400V	TG-K-NTC	DPS 2.30
CAD-COMPACT 2500 ADVANCED	MBE-400/60T-R 2/400V*	TG-K-NTC	DPS 2.30
CAD-COMPACT 3200 ADVANCED	MBE-400/60T-R 2/400V*	TG-K-NTC	DPS 2.30
CAD-COMPACT 4500 ADVANCED	MBE-450/90T-R 3/400V*	TG-K-NTC	DPS 2.30

\* In order to use the circular accessories it is necessary to install the corresponding PRRE adapter.

### External electric pre-heating batteries

Indicated for ventilation installations located in cold areas where outside temperatures are usually below  $-10^{\circ}\text{C}$ .

Under these conditions, it is advisable to install electric preheating batteries located in the external air intake of the recovery unit, which increase the temperature of the external air, avoiding the continuous activation of the heat exchanger protection and the discomfort that this may cause.

Model	Control of an external electric preheating coil	
	Regulated electric coil	Differential pressure switch
CAD-COMPACT 500 ADVANCED	MBE-200/20T-R 2/400V	DPS 2.30
CAD-COMPACT 900 ADVANCED	MBE-315/30T-R 2/400V	DPS 2.30
CAD-COMPACT 1300 ADVANCED	MBE-315/30T-R 2/400V	DPS 2.30
CAD-COMPACT 1800 ADVANCED	MBE-355/60T-R 2/400V	DPS 2.30
CAD-COMPACT 2500 ADVANCED	MBE-400/60T-R 2/400V*	DPS 2.30
CAD-COMPACT 3200 ADVANCED	MBE-400/60T-R 2/400V*	DPS 2.30
CAD-COMPACT 4500 ADVANCED	MBE-450/90T-R 3/400V*	DPS 2.30

\* In order to use the circular accessories it is necessary to install the corresponding PRRE adapter.

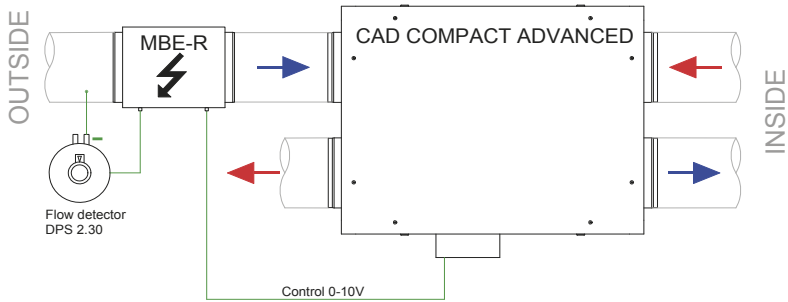

## 10.1. WIRING BETWEEN ACCESSORY AND ADVANCED ELECTRICAL BOARD

### 10.1.1. Post-heating and post-cooling battery modules

For all the coil modules (except pre heating), after mount the coil module it will be necessary to install an additional temperature probe fitted in the fresh air supply side which is supplied as accessory (TG-K-NTC). Cable length = 4 m.

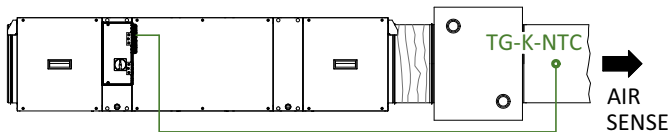

Insert the new probe downstream the coil module:

Once installed, wire the sensor to the controller, following the indications of the electrical diagrams that you will find in this manual. Specific detail for coils management.

Probe to the electric cabinet, according to the indications in the electric diagrams annex.

#### Particularities of BA-AF reversible modules (cooling and heating)

The selection between winter and summer mode can be done manually by means of a commutator switch. It is also possible to automatically detect the working mode (Cooling-Heating) by means of one Change-over thermostat (accessory) **5416783700 THCO**

The Change-Over thermostat **COM-2** must be mounted in the reversible coil inlet collector, from where it detects when the received water is cool or hot (heat pump in summer or winter mode)

Once installed, rewire the THCO thermostat to the electric cabinet, according to the electric diagrams annex.

## 10.2. CONFIGURATION OF EXTERNAL MODULES OF REFRIGERATION / HEATING BATTERIES

Before starting the configuration of the control, the control must be in STOP mode. With the unit running (fans on) the configuration will not be saved.

Once the required rewire was done, it will be necessary to reconfigure the ADVANCED controller from the PRODUCER menu.

The configuration of the factory menu parameters requires identification by password. The default password is 1951.

Access to factory menu parameters from the main menu:

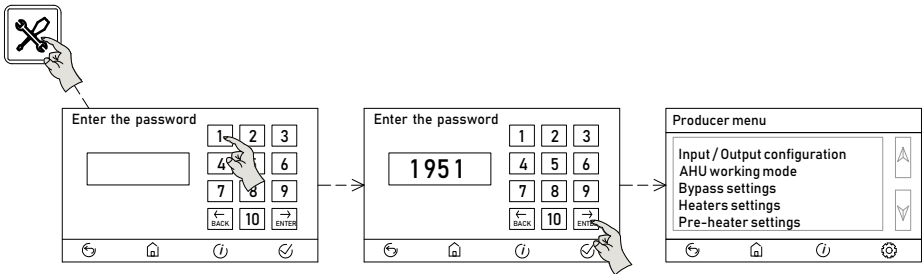

Content of the functions and parameters accessible from the advanced parameters / Installer menu:

### 10.2.1. Configuration of an external post-heating water coil

Select "Heaters settings" and Water (0-100%) post-heating coil:

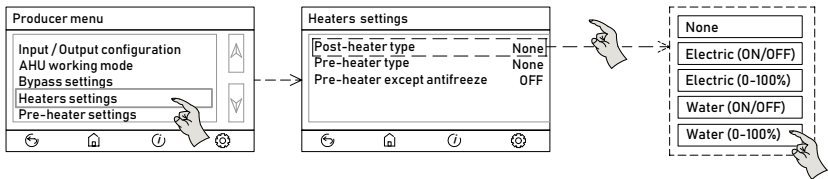

Define the working mode in Winter or Auto mode. In case of auto the controller will detect the change of season automatically according to the values of the integrated temperature probes:

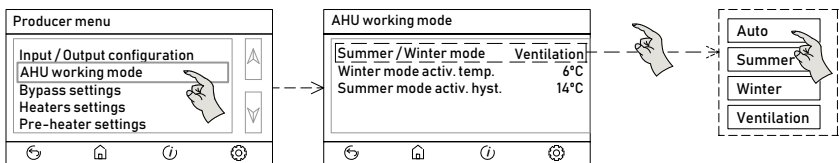

Enable the post-heater temperature probe TG-K-NTC, (accessory) that previously had to be installed downstream the water coil:

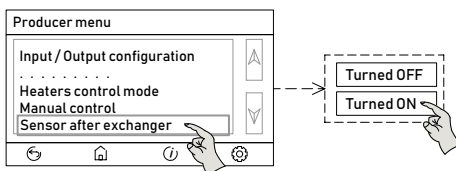

Assign the regulation signal of the hot water valve to one of the available analog outputs:

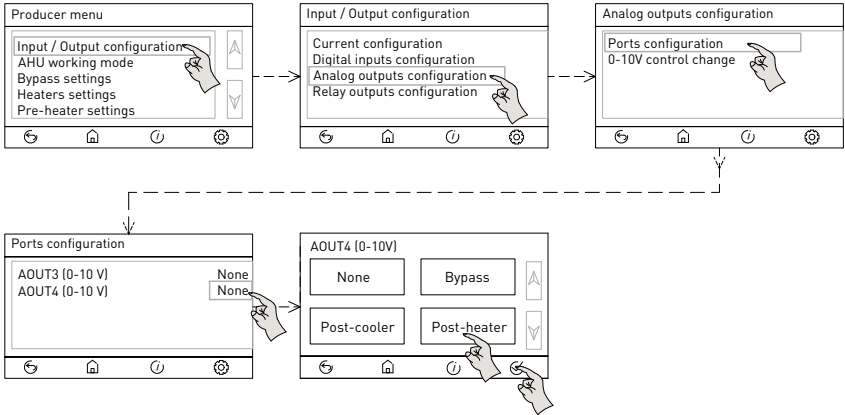

It is possible to modify the default setting of the heating regulation signal:

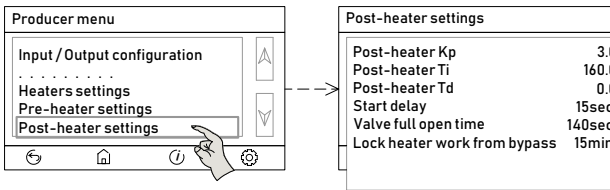

### 10.2.2. Configuration of an external heating coil (post-heating)

Select "Heaters settings" and and post-electric heating (0-100%):

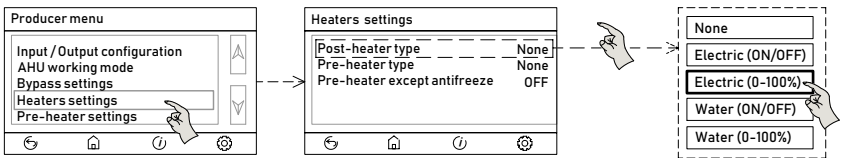

Define the working mode in Winter or Auto mode. In case of auto will the controller detect the change of season automatically according to the values of the integrated temperature probes:

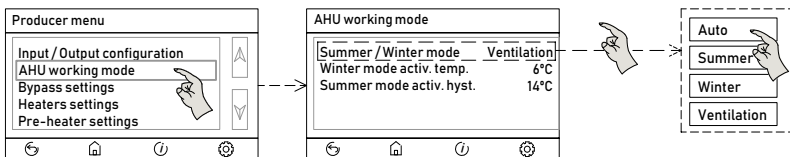

Enable the for post-heating control temperature probe TG-K-NTC, (accessory) installed downstream the electric battery:

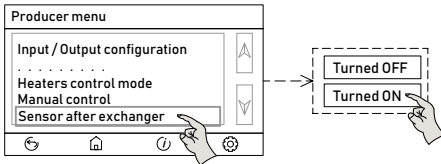

Assign the electric coil regulation signal to one of the available analog outputs:

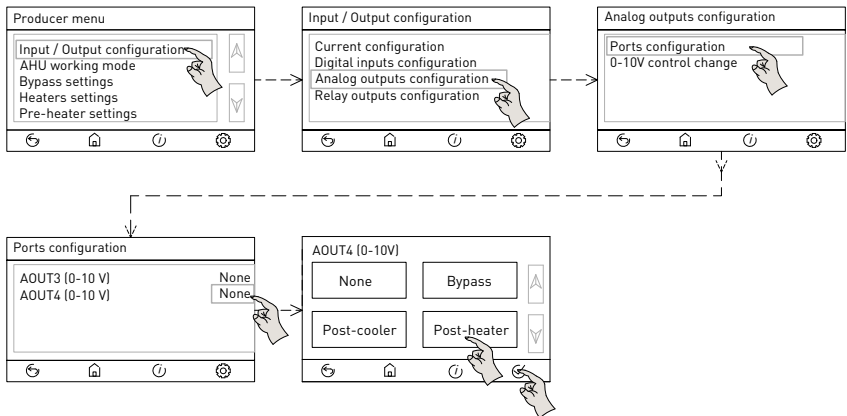

It is possible to modify the default setting of the heating regulation signal:

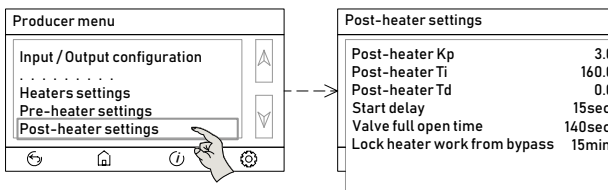

### 10.2.3. Configuration of an external water cooling coil (post-cooling)

Select "Battery Settings refrigeration" and activate the cold coil:

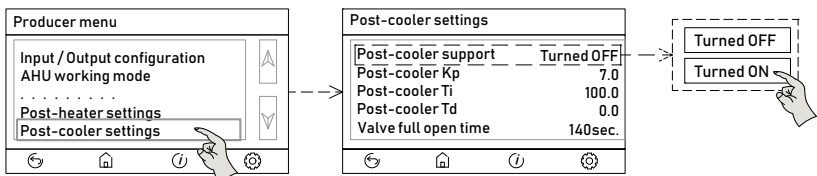

In the same screen it is possible to define the post-cooler regulation parameters. Define the working mode in Summer or Auto mode. In case of auto will the controller detect the change of season automatically according to the values of the integrated temperature probes:

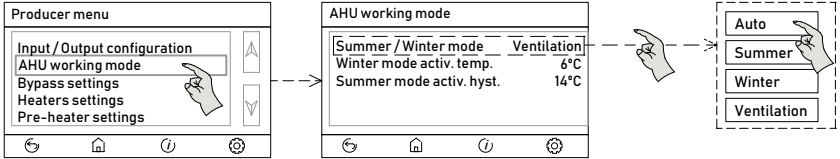

Enable the post-heater temperature probe TG-K-NTC, (accessory) installed downstream the water coil:

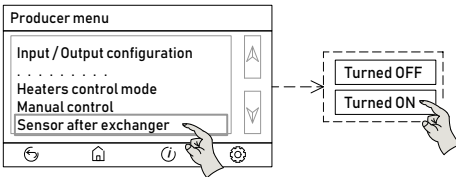

Assign the cold water valve regulation signal to one of the available analog outputs:

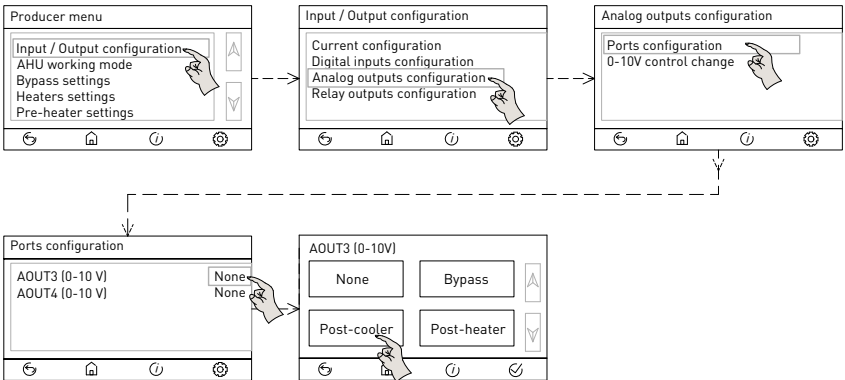

### 10.2.4. Configuration of an external electric preheating coil

Enter "Heaters settings" and select Electric preheating (0-100%):

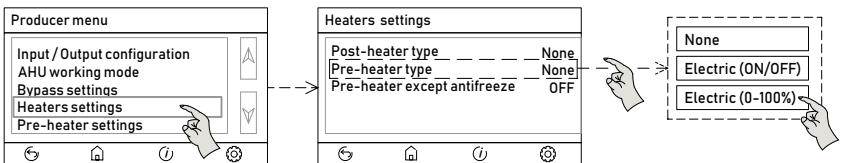

Define the working mode in Winter or Auto mode. In case of auto the controller will detect the change of season automatically according to the values of the integrated temperature probes:

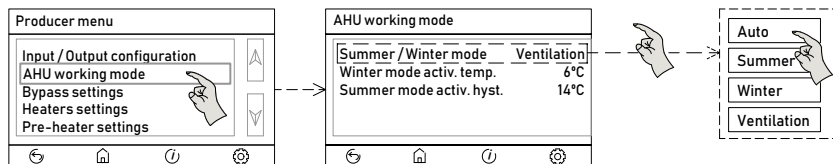

Assign the electric coil regulation signal to one of the available analog outputs:

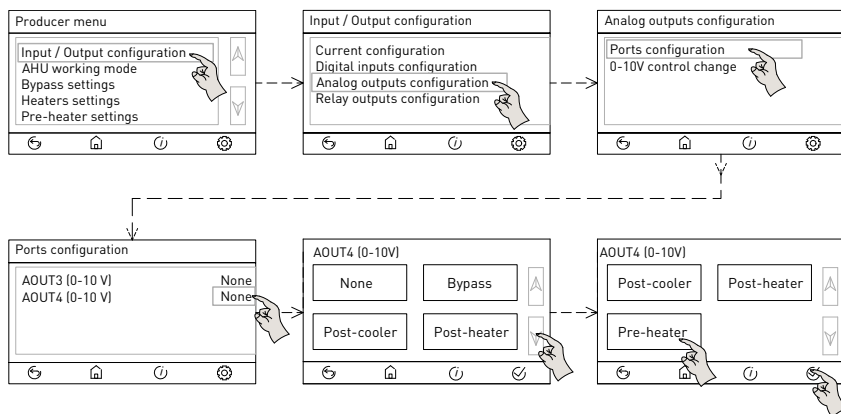

It is possible to modify the default setting of the heating regulation signal:

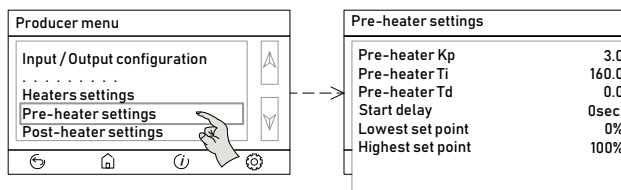

## 11. UPDATE THE CONTROLLER

In some cases it may be necessary to update the version of the ADVANCED control software (Development of new functionalities, improvements, new languages...). The controller has separate softwares, for the controller and for the hand terminal.

To update the version, it is necessary to copy the new software versions in a microSD card. Insert the microSD card in the slot at the bottom back of the remote hand terminal.

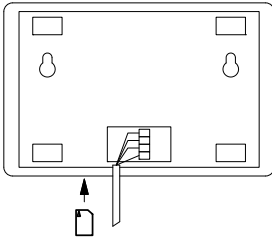

**The Software Update menu is not shown if there is no SD card fitted in the slot**

Before starting the update process, it is shown the current and the new software versions.  
 Process to update the remote hand terminal software:

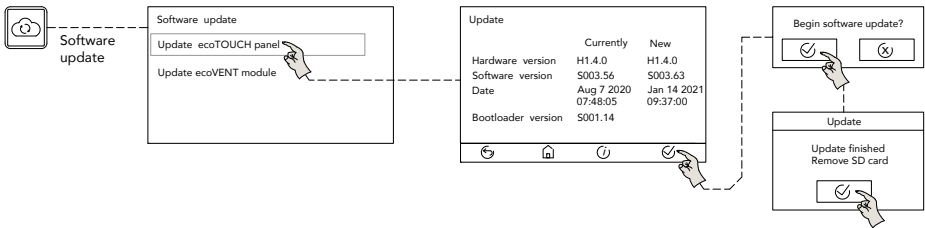

Process to update the controller software:

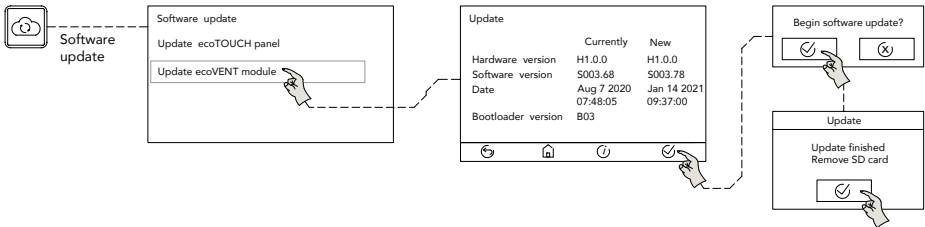

## 12. CONTROLLER RECONFIGURATION

### IMPORTANT

After load a new software version, it is necessary to reconfigure the unit, as the factory settings are deleted.

Necessary reconfiguration:

- Language
- Time schedule
- Fan working mode
- K Factor (in case of COP /CAV modes)
- Pressure sensor (in case of COP /CAV modes)
- Pre-heater configuration (if exists)
- Post-heater / Post-cooler configuration (if exists)
- Configuration of special functions (fire function, remote stop-start and other special functions) if they have been configured



### 13. BUILDING MANAGEMENT SYSTEM (BMS) CONNECTION

The controller has a Modbus communication module through which it is possible to control the unit from an external BMS, as well as monitor a large part of the functional variables of the unit.

By default, the communication is enabled, therefore to control the unit via an external BMS it is that simple to wire the RS-485 net to the main board connectors COM3 and ISO.

The use of the remote controller and the integration to BMS are compatible. The controller will obey the last order received regardless of where it comes from. To avoid interactions between orders, it is recommended that once the unit is integrated into the Modbus network, proceed to unwire the remote control.

#### ADVANCED characteristics of the Modbus-RTU controller

Addressing	Slave: configurable address from 1 to 247
Diffusion	Yes
Transmission speed	19200 (Selectable values: 9200 / 115200)
Parity	None (Selectable values: Even / Odd)
Mode	RTU
Electrical interface	RS-485 2W-wired or RS232

#### MODBUS message

Address	Function	Data	CRC verification
8 bits	8 bits	N x 8 bits	16 bits

The format for each byte in RTU mode is:

Code system: 8-bit binary

Bits per Byte: 1 bit of START (start)

8 data bits, the most significant bit is sent the first

1 bit for the parity

1 bit of STOP (configurable 2 bits of STOP)

The modification of the Modbus parameters is done through the Modbus settings in the installer menu:

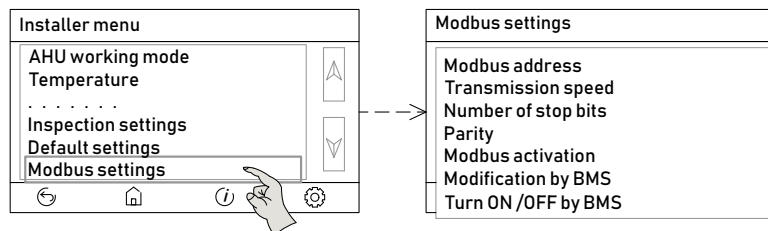



## Modbus memory map

Modbus address	Register description	Value			Register options	Variable type	Notes
		Min.	Max.	Def.			
0	ecoVENT program version	0	0xFFFF	0	R	HEX	Format: SXXX.YYY XXX – older byte, YYY – younger byte
1	Factory number – chars 1 and 2	12336	23130	-	R	ASCII	-
2	Factory number – chars 3 and 4	12336	23130	-	R	ASCII	-
3	Factory number – chars 5 and 6	12336	23130	-	R	ASCII	-
4	Factory number – chars 7 and 8	12336	23130	-	R	ASCII	-
5	Factory number – chars 9 and 10	12336	23130	-	R	ASCII	-
6	UID - chars 1 and 2	12336	23130	-	R	ASCII	-
7	UID - chars 3 and 4	12336	23130	-	R	ASCII	-
8	UID - chars 5 and 6	12336	23130	-	R	ASCII	-
9	UID - chars 7 and 8	12336	23130	-	R	ASCII	-
10	UID - chars 9 and 10	12336	23130	-	R	ASCII	-
11	UID - chars 11 and 12	12336	23130	-	R	ASCII	-
12	UID - chars 13 and 14	12336	23130	-	R	ASCII	-
13	UID - chars 15 and 16	12336	23130	-	R	ASCII	-
14	UID - chars 17 and 18	12336	23130	-	R	ASCII	-
15	UID - chars 19 and 20	12336	23130	-	R	ASCII	-
16	UID - char 21	48	90	-	R	ASCII	-
17	Correct work status of the unit (supply or exhaust fans should be on)	0	1	1	R	integer	0 – unit (fans) stops; 1 – unit (fans) works
18	Unit alarm state	0	1	0	R	integer	0 – inactive; 1 – active
19	Minute to be set in internal clock	0	59	1	R/W	integer	
20	Hour to be set in internal clock	0	23	1	R/W	integer	
21	Day of month to be set in ecoVENT internal clock	1	31	1	R/W	integer	
22	Month to be set in internal clock	1	12	1	R/W	integer	
23	Year to be set in internal clock	2015	2099	2021	R/W	integer	
24	Regulation set on main temperature sensor	-40	85	0	R	integer	999 – if sensor were damaged; Unit: °C
25	Set temperature for regulation	8	30	0	R/W	integer	Unit: °C
26	Supply air temperature	-40	85	0	R	integer	999 – if sensor were damaged; Unit: °C
27	Extraction air temperature	-40	85	0	R	integer	999 – if sensor were damaged; Unit: °C
28	Exhausted air temperature	-40	85	0	R	integer	999 – if sensor were damaged; Unit: °C
29	Outdoor air temperature	-40	85	0	R	integer	999 – if sensor were damaged; Unit: °C
30	-	-	-	-	-	-	-
31	-	-	-	-	-	-	-
32	-	-	-	-	-	-	-
33	Main sensor number	2	3	3	R/W	integer	2 – supply sensor; 3 – extraction sensor

Modbus address	Register description	Value			Register options	Variable type	Notes
		Min.	Max.	Def.			
34	State of digital inputs	0	31	0	R	HEX	0x01 – DIN1 shorten; 0x02 – DIN2 shorten; 0x04 – DIN3 shorten; 0x08 – DIN4 shorten; 0x10 – DIN5 shorten
35	Signal from pre-heater thermostat	0	1	0	R	integer	0 – no signal; 1 – signal is active
36	Signal form post-heater thermostat	0	1	0	R	integer	0 – no signal; 1 – signal is active
37	Signal from thermostats (i. e. for two electrical heaters)	0	1	0	R	integer	0 – no signal; 1 – signal is active
38	Signal from burglar alarm system	0	1	0	R	integer	0 – no signal; 1 – signal is active
39	Signal from Fire Alarm System (FAS)	0	1	0	R	integer	0 – no signal; 1 – signal is active
40	-	-	-	-	-	-	-
41	-	-	-	-	-	-	-
42	Remote deactivation signal	0	1	0	R	integer	0 – no signal; 1 – signal is active
43	Boost activation signal	0	1	0	R	Integer	0 – no signal; 1 – signal is active
44	Signal from pressure switch (supply air filter or exhaust air filter)	0	1	0	R	Integer	0 – no signal; 1 – signal is active
45	-	-	-	-	-	-	-
46	Signal from fan supervision system (pressure switches)	0	1	0	R	integer	0 – no signal; 1 – signal is active
47	-	-	-	-	-	-	-
48	-	-	-	-	-	-	-
49	Anti-freeze signal from heating-cooling unit	0	1	0	R	integer	0 – no signal; 1 – signal is active
50	-	-	-	-	-	-	-
51	-	-	-	-	-	-	-
52	-	-	-	-	-	-	-
53	-	-	-	-	-	-	-
54	Relay outputs state (both: voltage and non-voltage)	0	31	0	R	HEX	0x01 – OUT1 active; 0x02 – OUT2 active; 0x04 – OUT3 active; 0x08 – REL1 active; 0x10 – REL2 active; 0x20 – REL3 active
55	Operating mode for supply air fan	0	1	0	R	integer	0 – supply fan OFF 1 – supply fan ON
56	Supply air fan current control	0	100	0	R	integer	Unit: %
57	Operating mode for exhaust air fan	0	1	0	R	integer	0 – exhaust fan OFF 1 – exhaust fan ON
58	Exhaust air fan current control	0	100	0	R	integer	Unit: %
59	Differential pressure measured - supply air	0	1000	0	R	integer	Unit: Pa



Modbus address	Register description	Value			Register options	Variable type	Notes
		Min.	Max.	Def.			
60	Differential pressure measured - exhaust air	0	1000	0	R	integer	Unit: Pa
61	Flow measured - supply air	0	4000	0	R	integer	Unit: m3/h
62	Flow measured - exhaust air	0	4000	0	R	integer	Unit: m3/h
63	Bypass operation mode	0	1	0	R	integer	0 – bypass OFF; 1 – bypass ON
64	Bypass damper current control	0	100	0	R	integer	Unit: %
65	Pre-heater operation mode	0	1	0	R	integer	0 – pre-heater OFF; 1 – pre-heater ON
66	Pre-heater current control	0	100	0	R	integer	Unit: %
67	Post-heater operation mode	0	1	0	R	integer	0 – post-heater OFF; 1 – post-heater ON
68	Post-heater current control	0	100	0	R	integer	Unit: %
69	Cooler operating mode	0	1	0	R	integer	0 – cooler OFF; 1 – cooler ON
70	Cooler current control	0	100	0	R	integer	Unit: %
71	Current operating mode for heating – cooling unit	0	2	0	R	integer	0 – unit OFF 1 – unit in heating mode 2 – unit in cooling mode
72	Current control for heating – cooling unit	0	100	0	R	integer	Unit: %
73	Measured CO <sub>2</sub>	0	2000	0	R	integer	Unit: ppm; Parameter value rounded to 1
74	Measured relative humidity	0	100	0	R	integer	Unit: %; Parameter value rounded to 1
75	-	-	-	-	-	-	-
76	-	-	-	-	-	-	-
77	-	-	-	-	-	-	-
78	-	-	-	-	-	-	-
79	Set regulation mode	1	4	0	R/W	integer	0x01 – VAV mode; 0x02 – CAV mode; 0x04 – COP mode
80	Set operating mode	0	15	0	R/W	integer	0 – OFF mode; 2 – manual control; 3 – mode 1; 4 – mode 2; 5 – mode 3; 8 – mode AUTO VAV; 9 – mode AUTO CAV; 10 – mode AUTO COP; 12 – mode timer VAV; 13 – mode timer CAV; 14 – mode timer COP
81	Current season mode (Summer / Winter mode)	0	4	4	R/W	integer	0x01 – Summer mode; 0x02 – Winter mode; 0x04 – Auto mode
82	Temperature with winter mode being turned ON	-20	20	6	R/W	integer	Unit: °C

Modbus address	Register description	Value			Register options	Variable type	Notes
		Min.	Max.	Def.			
83	Hysteresis with summer mode being turned ON	0	20	14	R/W	integer	Unit: °C
84	Anti-freezing mode state	0	1	0	R	integer	0 – anti-freezing mode inactive; 1 – anti-freezing mode active
85	Pre-set supply air fan control in VAV 1 mode	Dyn.*	Dyn.*	100	R/W	integer	Unit: %
86	Pre-set exhaust air fan control in VAV 1 mode	Dyn.*	Dyn.*	100	R/W	integer	Unit: %
87	Pre-set supply air fan control in VAV 2 mode	Dyn.*	Dyn.*	60	R/W	integer	Unit: %
88	Pre-set exhaust air fan control in VAV 2 mode	Dyn.*	Dyn.*	60	R/W	integer	Unit: %
89	Pre-set supply air fan control in VAV 3 mode	Dyn.*	Dyn.*	30	R/W	integer	Unit: %
90	Pre-set exhaust air fan control in VAV 3 mode	Dyn.*	Dyn.*	30	R/W	integer	Unit: %
91	Minimum voltage to start linear characteristic control by CO <sub>2</sub> in AUTO-VAV mode	0.0	10.0	2.0	R/W	float	Parameter resolution: 0.1; to modify the parameter please send: requested value x 10
92	Maximum voltage end linear characteristic control by CO <sub>2</sub> in AUTO-VAV mode	0.0	10.0	8.0	R/W	float	Parameter resolution: 0.1; to modify the parameter please send: requested value x 10
93	Pre-set SAF and EAF control at start of linear characteristic in AUTO-VAV mode	2	10	4.5	R/W	float	Parameter resolution: 0.1; to modify the parameter please send: requested value x 10
94	Pre-set SAF and EAF control at the end of linear characteristic in AUTO-VAV mode	Dyn.**	10	10	R/W	float	Parameter resolution: 0.1; to modify the parameter please send: requested value x 10
95	Exhaust fan control shift in AUTO-VAV mode	-50	50	0	R/W	integer	Unit: %
96	Pre-set airflow - supply air in CAV 1 mode	0	4000	3000	R/W	integer	Unit: m3/h
97	Pre-set airflow - exhaust air in CAV 1 mode	0	4000	3000	R/W	integer	Unit: m3/h
98	Pre-set airflow - supply air in CAV 2 mode	0	4000	2000	R/W	integer	Unit: m3/h
99	Pre-set airflow - exhaust air in CAV 2 mode	0	4000	2000	R/W	integer	Unit: m3/h
100	Pre-set airflow - supply air in CAV 3 mode	0	4000	1000	R/W	integer	Unit: m3/h
101	Pre-set airflow - exhaust air in CAV 3 mode	0	4000	1000	R/W	integer	Unit: m3/h
102	Set main fan in COP mode	1	2	1	R/W	integer	0x01 – main sensor: supply 0x02 – main sensor: exhaust



Modbus address	Register description	Value			Register options	Variable type	Notes
		Min.	Max.	Def.			
103	Pre-set differential pressure in supply air duct in COP 1 mode	0	1000	150	R/W	integer	Unit: Pa
104	Pre-set differential pressure in exhaust air duct in COP 1 mode	0	1000	150	R/W	integer	Unit: Pa
105	Pre-set differential pressure in supply air duct in COP 2 mode	0	1000	100	R/W	integer	Unit: Pa
106	Pre-set differential pressure in exhaust air duct in COP 2 mode	0	1000	100	R/W	integer	Unit: Pa
107	Pre-set differential pressure in supply air duct in COP 3 mode	0	1000	50	R/W	integer	Unit: Pa
108	Pre-set differential pressure in exhaust air duct in COP 3 mode	0	1000	50	R/W	integer	Unit: Pa
109	Bypass damper actual control mode	0	3	0	R/W	integer	0 – Bypass OFF; 1 – Bypass ON; 2 – Bypass AUTO; 3 – Freecooling
110	-	-	-	-	-	-	-
111	Analog air quality sensor settings	0	2	0	R/W	integer	0 – OFF 1 – CO <sub>2</sub> sensor 2 – relative humidity sensor
112	ECO work mode (steering from burglar alarm central)	0	2	1	R/W	integer	0 – OFF 1 – ECO-TURN OFF 2 – ECO-WORK
113	Ventilation mode	0	1	0	R/W	integer	0 – Ventilation OFF; 1 – Ventilation ON
114	Pre-set supply air fan control in ECO-WORK mode	Dyn.*	Dyn.*	50	R/W	integer	Unit: %
115	Pre-set exhaust air fan control in ECO-WORK mode	Dyn.*	Dyn.*	50	R/W	integer	Unit: %
116	Pre-set supply air fan control in Ventilation mode	Dyn.*	Dyn.*	50	R/W	integer	Unit: %
117	Pre-set exhaust air fan control in Ventilation mode	Dyn.*	Dyn.*	50	R/W	integer	Unit: %
118	Ventilation duration	1	100	10	R/W	integer	Unit: min.
119	Interval between subsequent ventilation sessions	1	24	1	R/W	integer	Unit: h
120	Boost mode settings	0	1	0	R/W	integer	0 – control from button in panel 1 – control from external switch
121	Boost duration (only if controlled from panel button)	1	120	30	R/W	integer	Unit: min.
122	Pre-set supply air fan control in Boost mode	Dyn.*	Dyn.*	100	R/W	integer	Unit: %
123	Pre-set exhaust air fan control in Boost mode	Dyn.*	Dyn.*	100	R/W	integer	Unit: %
124	Cleaning mechanism settings	0	1	0	R/W	integer	0 – cleaning mechanism turn OFF; 1 – cleaning mechanism turn ON

Modbus address	Register description	Value			Register options	Variable type	Notes
		Min.	Max.	Def.			
125	Cleaning mechanism manual mode turned ON	0	1	0	R/W	integer	0 – no; 1 – yes
126	Too high supply temperature protection procedure	0	2	1	R/W	integer	0 – turn OFF procedure; 1 – turn OFF AHU; 2 – turn OFF post-heater
127	Too low supply temperature protection procedure	0	2	1	R/W	integer	0 – turn OFF procedure; 1 – turn OFF SAF; 2 – Turn ON post- heater
128	Supply air temperature higher limit	30	80	70	R/W	integer	Unit: °C
129	Operation pause in AHU OFF mode	10	100	10	R/W	integer	Unit: min.
130	Supply air temperature low limit	1	25	5	R/W	integer	Unit: °C
131	Low temperature detection time	1	15	3	R/W	integer	Unit: min.
132	Filters contamination detection time	0	60	30	R/W	integer	Unit: sec.
133	Anti-freeze procedure settings	0	1	1	R/W	integer	0 – procedure turn OFF 1 – procedure turn ON
134	Pre-set exhaust air fan control during anti-freeze procedure	Dyn.*	Dyn.*	70	R/W	integer	Unit: %
135	Pre-set supply air fan control at start of the anti-freeze procedure	Dyn.*	Dyn.*	70	R/W	integer	Unit: %
136	Pre-set supply air fan control during anti-freeze procedure	Dyn.*	Dyn.*	30	R/W	integer	Unit: %
137	Anti-freeze procedure turn ON temperature	-10	10	3	R/W	integer	Unit: °C
138	Anti-freeze procedure turn OFF hysteresis	1	10	3	R/W	integer	Unit: °C
139	Lowest detection time to start anti-freeze procedure	0	5	2	R/W	integer	Unit: min.
140	Supply air fan lower set point	0	50	25	R/W	integer	Unit: %
141	Exhaust air fan lower set point	0	50	25	R/W	integer	Unit: %
142	Supply air fan higher set point	50	100	100	R/W	integer	Unit: %
143	Exhaust air fan higher set point	50	100	100	R/W	integer	Unit: %
144	Supply air fan stop delay (after heater work)	1	20	2	R/W	integer	Unit: min.
145	Exhaust air fan stop delay (after heater work)	0	20	2	R/W	integer	Unit: min
146	Supply fan start delay	0	200	0	R/W	integer	Unit: sec.
147	Exhaust fan start delay	0	200	0	R/W	integer	Unit: sec.
148	Source channel for measurement differential pressure in supply air duct	0	1	1	R/W	integer	0 – internal sensor ΔP1 1 – external sensor connected to AIN1
149	Differential pressure measured by external sensor corresponding to minimum voltage processed by AIN 1	0	1000	1000	R/W	integer	Unit: Pa



Modbus address	Register description	Value			Register options	Variable type	Notes
		Min.	Max.	Def.			
150	Differential pressure measured by external sensor corresponding to maximum voltage processed by AIN 1	0	1000	0	R/W	integer	Unit: Pa
151	Minimum voltage processed on analog input AIN1	0	10	0	R/W	integer	Unit: V
152	Maximum voltage processed on analog input AIN1	0	10	10	R/W	integer	Unit: V
153	K factor for supply air fan	0	1000	84	R/W	float	Parameter resolution: 0.1; to modify the parameter please send: requested value x 10
154	Source channel for measurement differential pressure in exhaust air duct	0	1	1	R/W	integer	0 – internal sensor $\Delta P_2$ 1 – external sensor connected to AIN2
155	Differential pressure measured by external sensor corresponding to minimum voltage processed by AIN 2	0	1000	1000	R/W	integer	Unit: Pa
156	Differential pressure measured by external sensor corresponding to maximum voltage processed by AIN 2	0	1000	0	R/W	integer	Unit: Pa
157	Minimum voltage processed on analog input AIN2	0	10	0	R/W	integer	Unit: V
158	Maximum voltage processed on analog input AIN2	0	10	10	R/W	integer	Unit: V
159	K factor for exhaust air fan	0	1000	84	R/W	float	Parameter resolution: 0.1; to modify the parameter please send: requested value x 10
160	Manual control – relay outputs	0	63	0	R/W	integer	0x01 – turn ON OUT1 0x02 – turn ON OUT2 0x04 – turn ON OUT3 0x08 – turn ON REL1 0x10 – turn ON REL2 0x20 – turn ON REL3
161	Manual control – AOUT1	0	100	0	R/W	integer	To set value in volts please send: requested value x10
162	Manual control – AOUT2	0	100	0	R/W	integer	To set value in volts please send: requested value x10
163	Manual control – AOUT3	0	100	0	R/W	integer	To set value in volts please send: requested value x10
164	Manual control – AOUT4	0	100	0	R/W	integer	To set value in volts please send: requested value x10

Notes:

\* the value range of these parameters depends on set value: Minimum and maximum fan control

\*\* minimum value of this parameter depends on the value set as the lowest control set point (parameter 88)



Modbus address	Register description	Value			Register options	Variable type	Notes
		Min.	Max.	Def.			
200	Supply temperature sensor defective	0	1	0	R	integer	0 – alarm inactive; 1 – alarm active
201	Extraction temperature sensor defective	0	1	0	R	integer	0 – alarm inactive; 1 – alarm active
202	External temperature sensor defective	0	1	0	R	integer	0 – alarm inactive; 1 – alarm active
203	Exhaust temperature sensor defective	0	1	0	R	integer	0 – alarm inactive; 1 – alarm active
204	-	-	-	-	-	-	-
205	-	-	-	-	-	-	-
206	-	-	-	-	-	-	-
207	-	-	-	-	-	-	-
208	Contamination of supply air filter or exhaust air filter	0	1	0	R	integer	0 – alarm inactive; 1 – alarm active
209	General inspection required on manufacturer service	0	1	0	R	integer	0 – alarm inactive; 1 – alarm active
210	No confirmation of fans correct operation	0	1	0	R	integer	0 – alarm inactive; 1 – alarm active
211	Possible overheating of pre-heater	0	1	0	R	Integer	0 – alarm inactive; 1 – alarm active
212	Possible overheating of post-heater	0	1	0	R	Integer	0 – alarm inactive; 1 – alarm active
213	-	-	-	-	-	-	-
214	-	-	-	-	-	-	-
215	-	-	-	-	-	-	-
216	Anti-freeze procedure activation for post-heater	0	1	0	R	Integer	0 – alarm inactive; 1 – alarm active
217	Too high supply temperature – protection procedure turned ON	0	1	0	R	Integer	0 – alarm inactive; 1 – alarm active
218	Too low supply temperature – protection procedure turned ON	0	1	0	R	Integer	0 – alarm inactive; 1 – alarm active

## 14. INSPECTION, MAINTENANCE AND CLEANING

### 14.1. Filters replacement

The maintenance side for filters replacement depends on the model and version. The exact ubication of the filters is identified by a label in the unit profile that indicates the type of filter and its characteristics.



#### **FALLING OBJECTS**

**When loosening the screws that hold the panels, they will be released. In units installed in ceiling, pay special attention to this operation to prevent the fall of a panel. During the maintenance signpost the area below the heat recovery unit and prevent person access to it.**



Access to filters is done by removing the two registration panels located on the side of the heat recovery unit. To replace the filters, follow the following sequence:

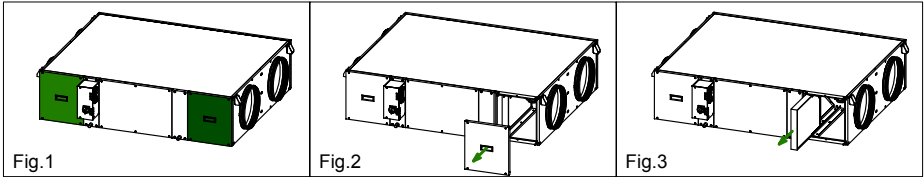

1. Access to the filters is done by removing the two existing side panels on the side where the electrical cabinet is located (Fig.1).
2. Remove the 4 screws that fix the filter access panel. Hold the panel preventing it from falling when loosening the last screw. (Fig 2).
3. Pull the dirty filter outwards, sliding it on the existing guide.

In the process of assembling the new filter, follow the reverse order, paying attention to the arrow that defines the direction of the air that you will find in the new S&P filter.

### Filters spare parts table

Model	Accessory filters and spare parts for CAD-COMPACT*			
	G4	M5	F7	F9
CAD-COMPACT 500	AFR-CAD-COMPACT 500 G4	AFR-CAD-COMPACT 500 M5	AFR-CAD-COMPACT 500 F7	AFR-CAD-COMPACT 500 F9
CAD-COMPACT 900	AFR-CAD-COMPACT 900 G4	AFR-CAD-COMPACT 900 M5	AFR-CAD-COMPACT 900 F7	AFR-CAD-COMPACT 900 F9
CAD-COMPACT 1300	AFR-CAD-COMPACT 1300 G4	AFR-CAD-COMPACT 1300 M5	AFR-CAD-COMPACT 1300 F7	AFR-CAD-COMPACT 1300 F9
CAD-COMPACT 1800	AFR-CAD-COMPACT 1800 G4	AFR-CAD-COMPACT 1800 M5	AFR-CAD-COMPACT 1800 F7	AFR-CAD-COMPACT 1800 F9
CAD-COMPACT 3200	AFR-CAD-COMPACT 3200 G4	AFR-CAD-COMPACT 3200 M5	AFR-CAD-COMPACT 3200 F7	AFR-CAD-COMPACT 3200 F9
CAD-COMPACT 4500	AFR-CAD-COMPACT 4500 G4	AFR-CAD-COMPACT 4500 M5	AFR-CAD-COMPACT 4500 F7	AFR-CAD-COMPACT 4500 F9

\* From factory the units are supplied with F7 filter in supply side and M5 in extraction. All models allow the installation of a second filter inside, obtaining, among others, the following combinations: F7+F9, M5+F7 or G4+F7.

### 14.2. ADDITIONAL FILTER INSTALLATION

The heat recovery is supplied with mounted filters.

Low pressure F7 filter for supply air and M5 for extract air.

Inside the heat recovery unit there is a specific rail for mounting a second additional filter (supplied as an accessory).

### 14.3. HEAT EXCHANGER

To perform the heat exchanger cleaning it is necessary to remove it from the unit. The disassembly can be easily done from the lateral panel:

#### Core disassembly sequence per side

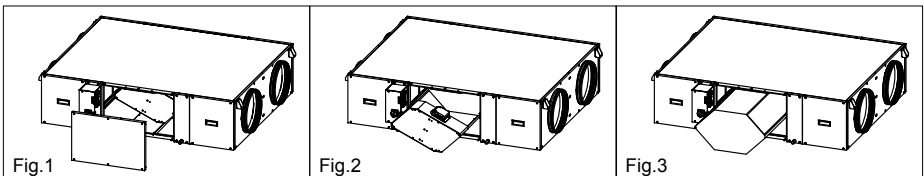

To disassemble of the heat exchanger follow the following sequence:

- Loosen the screws that hold the side panel. Before releasing the panel, ensure that it is well supported by the operator, preventing it from falling (Fig. 1).
- Remove the bypass assembly, releasing its electrical connector (Fig. 2).
- Pull the heat exchanger until it is completely removed from the equipment (Fig. 3).

#### 14.4. FANS

It is not necessary to access the fan to carry out maintenance tasks, nor to carry out the electrical connection since both fans are wired to the electrical cabinet. However, it is necessary to leave enough space around the unit in order to allow access to fans in case of its failure. Do not install the heat exchanger against a wall or an obstacle that prevents access to the fans.

If you need to replace the fan, follow the following sequence:

- Remove the access panel for the affected fan (Fig. 1).
- Release the screws that lock the metal plate on which the fan is mounted (Fig. 2).
- Pull out the plate and once outside, remove the fan and proceed to replace it (Fig. 3).

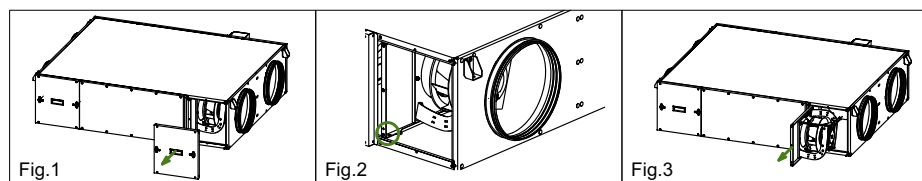

#### 14.5. CONDENSATION DRAINPIPE

Inspect the drainpipe regularly and make sure it is not blocked, if this is the case, remove the obstruction.

Check that the drain pipe was done according to the indication included in the point CONNECTIONS of this manual.

The siphon should always be full of water. Check its level periodically, refilling it if necessary. An empty siphon can cause the condensate tray to overflow and water leak through the equipment enclosure.



## 15. OPERATION ANOMALIES

### 15.1. General anomalies

Anomaly	Cause	Solution
Difficult to start.	Reduced power supply voltage. Insufficient static torque of motor.	Check motor specification plate. Close the air inlets to reach the maximum speed. Change the motor is necessary. Contact the <b>S&amp;P</b> Post-Sales service.
Insufficient airflow. Insufficient pressure.	Blocked pipes and/or inlet points closed. Fan obstructed. Filter overloaded. Insufficient rotation speed. Exchanger package blocked.	Clean inlet tubes. Clean fan. Clean or replace filter. Check power supply voltage. Clean the exchanger.
Reduction in performance after a period of acceptable operation.	Leaks in the circuit before and/or after the fan. Damaged roller.	Check the circuit and restore original conditions. Check the impeller and if necessary, replace with an original spare part. Contact the <b>S&amp;P</b> post sales service.
New air temperature too cold.	Outdoor air -5°C or less.	Insertion of post-heating resistances. Contact the <b>S&amp;P</b> post sales service.
Insufficient performance of the exchanger.	Fins dirty.	Clean the exchanger.
Formation of frost on the exchanger.	Outdoor air below -5°C.	Insertion of pre-heating devices (anti-ice). Contact the <b>S&amp;P</b> Customer Advice service.
Air pulsation.	Fan working in excessively low flow conditions. Flow instability, obstruction or bad connection.	Modification of the circuit and/or replacement of the fan. Clean and/or readjust the inlet channels. Operate the electronic regulator, increasing the minimum speed (insufficient voltage). Contact the <b>S&amp;P</b> Customer Advice service.
There is water inside the unit.	Drain clogged or wrongly dimensioned.	Check if exists a body/object obstructing the passage of water and remove it. Verify that the drain trap exists and is correctly sized according to the instructions of this manual.

### 15.2. LIST OF ALARMS

If an alarm is activated or an error occurs, the alarm indication will shown in the display:

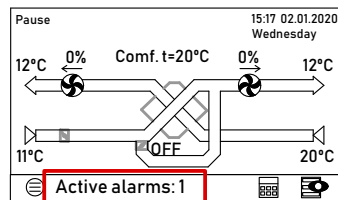
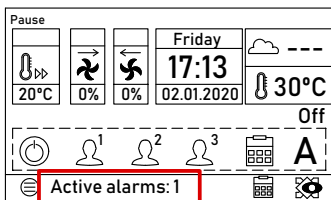

In case of alarm it is possible to access the alarms menu and get detailed information about the last alarms appeared:

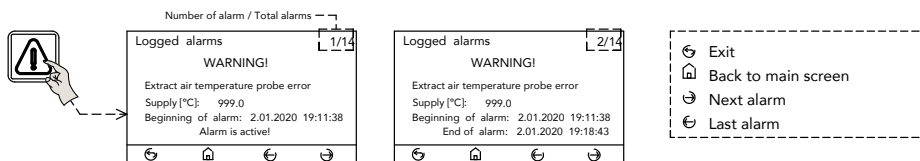

Alarm messages and possible causes:

Alarm message	Meaning	Correction
No communication with controller	The communication between controller and remote terminal is lost	Check wire and connections
SA pressure sensor communication error	The unit is configured in CAV or COP mode and is not receiving the signal from the pressure transmitter (accessory)	Check the pressure transmitter is installed and properly wired to main board
EA pressure sensor communication error	The unit is configured in CAV or COP mode and is not receiving the signal from the pressure transmitter (accessory)	Check the pressure transmitter is installed and properly wired to main board
Supply air temperature probe error	The controller is not receiving information from supply air temperature probe	Check the wiring / Replace the damaged probe
Aft. exchanger temperature probe error	The controller is not receiving information from the Aft. Exchanger temperature probe	Check the wiring / Replace the damaged probe
Exhausted air temperature probe error	The controller is not receiving information from exhaust air temperature probe	Check the wiring / Replace the damaged probe
Filters contamination poss	The filter is clogged	Clean / Replace the dirty filter
Outdoor air temperature probe error	The controller is not receiving information from the outdoor air temperature probe	Check the wiring / Replace the damaged probe
Extract air temperature probe error	The controller is not receiving information from the extract air temperature probe	Check the wiring / Replace the damaged probe
FAS signal support procedure is active	The FIRE alarm is activated	Check the status of the digital input from the fire alarm central
Filters lifetime has expired. Change them or call service	Filters lifetime counter indicates filter maintenance is required	Clean / Replace the dirty filter
Too high room supply air temperature	Supply temperature is too high	Check the temperature settings / Verify the post-heating components (water valve, battery...)
Overheated electric post-heater - 3x thermostat activ.	The electric post-heater thermal protection is activated	Increase the airflow / Verify the post-heating components (battery, probes, pressure switch, timer...)
Producer service general inspection required	Regular maintenance required	Call the S&P official service to perform a regular maintenance operation
Periodic inspection approaches	Regular maintenance required soon	-
Unauthorized start-up - device locked	The access code introduced is wrong - Access is blocked	Contact S&P service



Alarm message	Meaning	Correction
Pre-heater overheating possible	The electric pre-heater thermal protection is activated	Increase the airflow / Verify the pre-heating components (battery, probes, pressure switch, timer...)
Post-heater overheating possible	The electric post-heater thermal protection is activated	Increase the airflow / Verify the post-heating components (battery, probes, pressure switch, timer...)
Too low room supply air temperature	Supply temperature is too low	Check the temperature settings / Verify the post- heating components (water valve, battery...)
Thermostat signal. Post-heater antifreeze procedure	The electric post-heater thermal protection is activated	Increase the airflow / Verify the post-heating components (battery, probes, pressure switch, timer...)
Thermostat signal. Pre-heater antifreeze procedure	The electric pre-heater thermal protection is activated	Increase the airflow / Verify the pre-heating components (battery, probes, pressure switch, timer...)
Heaters thermostat(s) activation	Activación termostato batería	
Leading temperature probe error	The controller is not receiving information from the leading temperature probe	Check the wiring / Replace the damaged probe
Filter change time approaches	ALARMA\nSe aproxima cambio de filtros	
Lack of compatibility with regulator	Software version is not compatible with the hardware version	Contact S&P service
No fans work confirmation	Fans are stopped while should be running	Verify the fans wiring and state
Supply air filter replacement date is approaching	Supply air filter replacement date is approaching	Foresee revision in the next days
Exhausted air filter replacement date is approaching	Extract air filter replacement date is approaching	Foresee revision in the next days
Supply filter contamination - Turn OFF AHU and replace filter	Supply air filter is clogged	Turn off the unit and replace the filter
Extracted air filter contamination - Turn OFF AHU and replace filter	Extract air filter is clogged	Turn off the unit and replace the filter

Once the problem which generated the alarm is solved, it is possible to clear the alarm message:

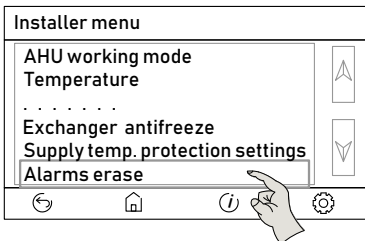



## 16.2. CAD-COMPACT 500 to 2500 advanced. Symmetric configuration.

### Supply air fan at right side (seen from the electrical cabinet)

(see chapter "Exchange the function of the supply and extraction circuits")

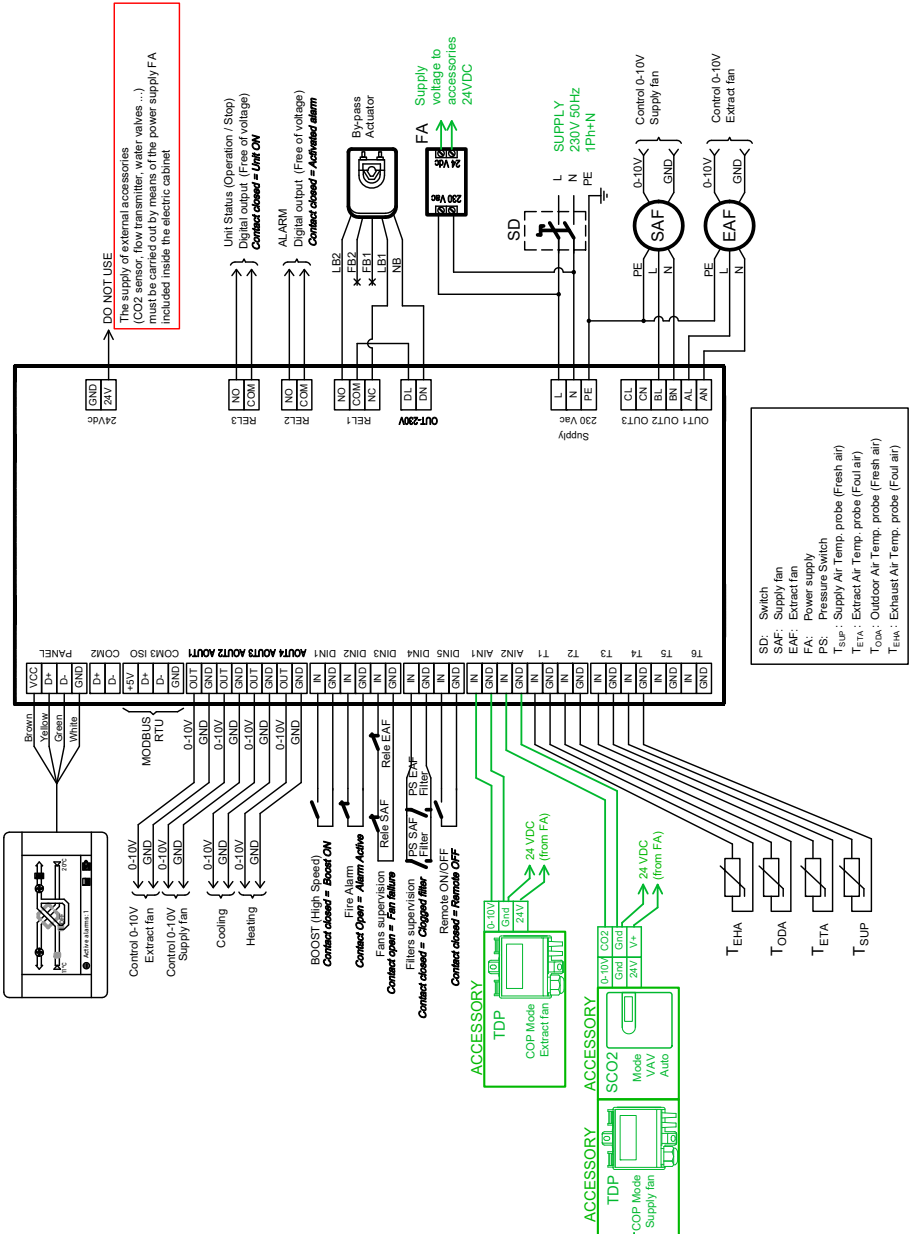





## 16.4. CAD-COMPACT ADVANCED 3200. Symmetric configuration. Supply air fan on the right side (seen from the electrical cabinet) (see chapter "Exchanging the function of supply and extraction circuits")

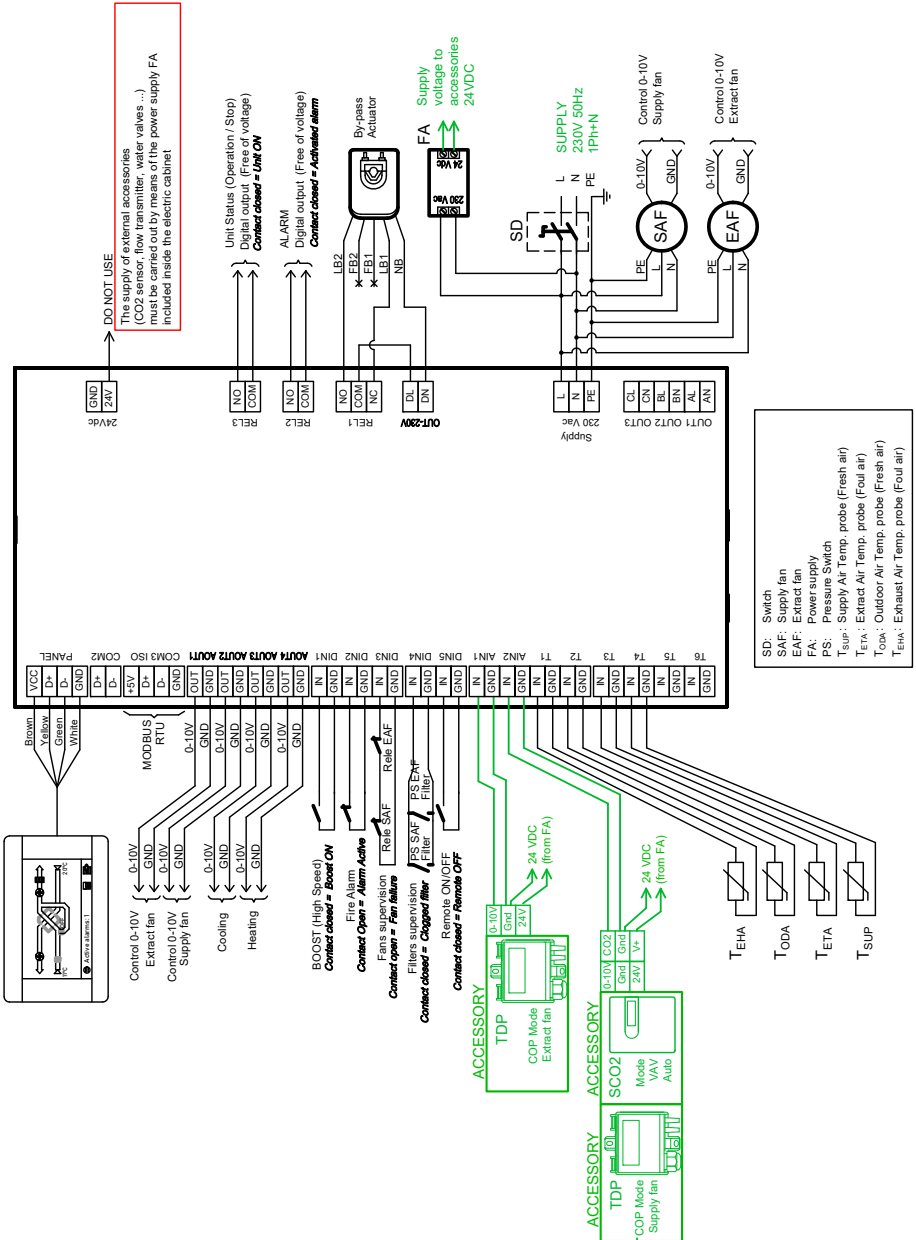

## 16.5. CAD-COMPACT 4500 ADVANCED. Configuration by default. Supply air fan at left side (seen from the electrical cabinet)

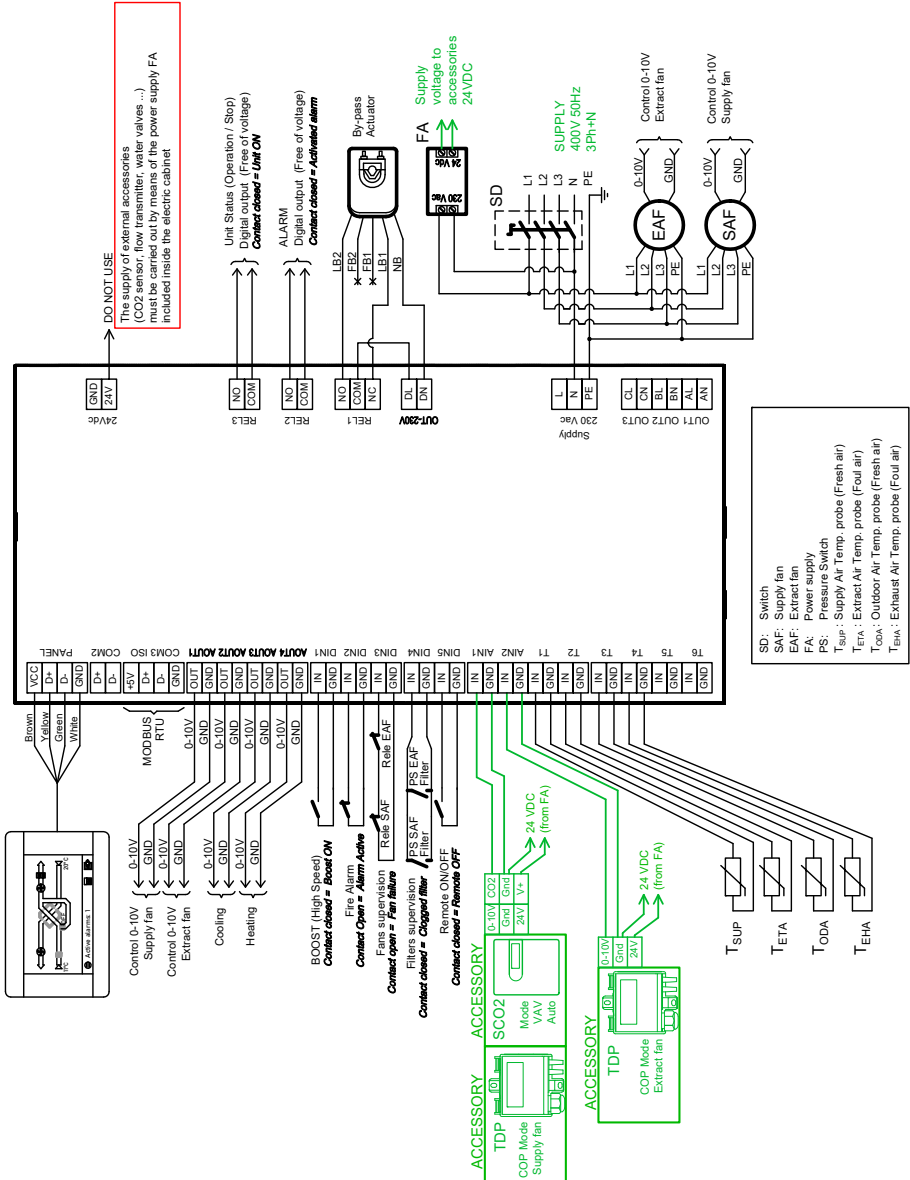



## 16.7. SPECIFIC WIRING TO CONTROL EXTERNAL COILS

### 16.7.1. Configuration by default. Supply air fan at left side (by default)

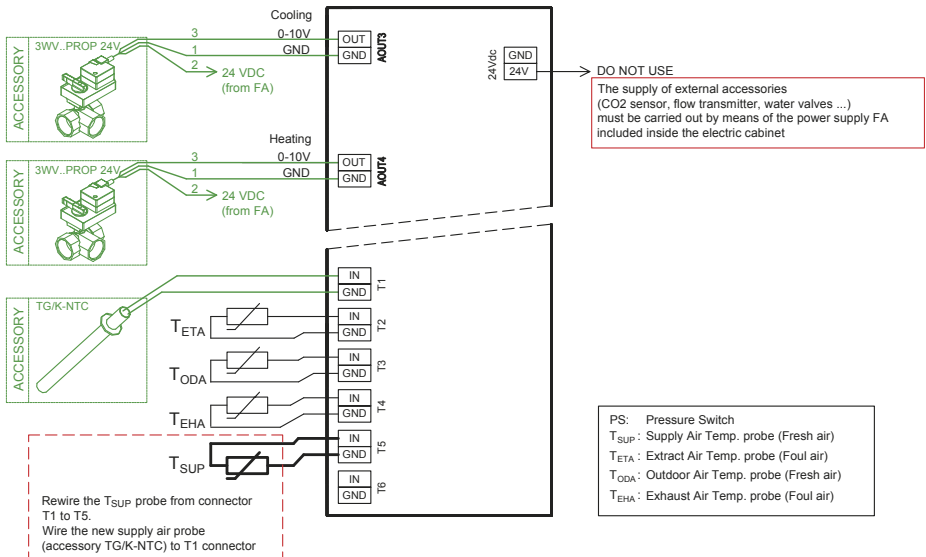

### 16.7.2. Symmetric configuration. Supply air fan at right side

(see chapter "Exchange the function of the supply and extraction circuits")

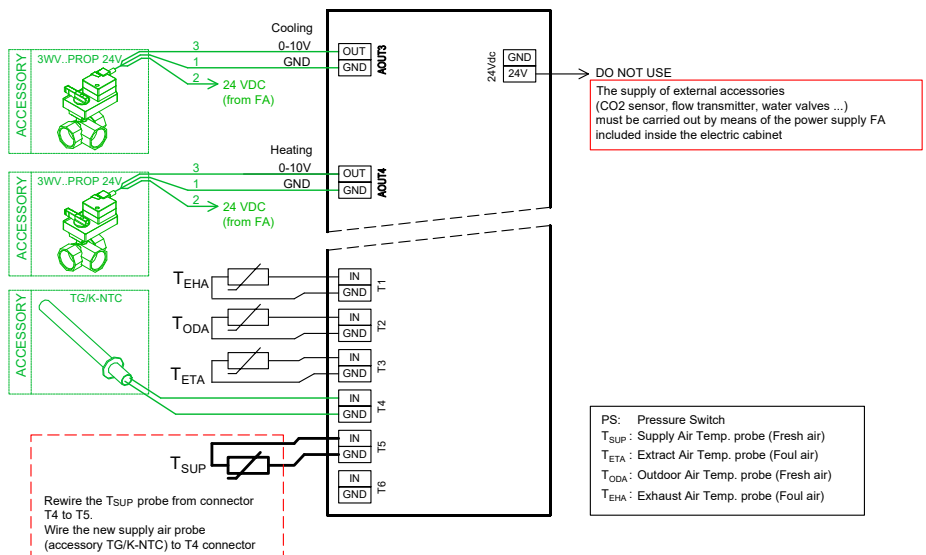



## 16.8. SPECIFIC WIRING TO CONTROL POST-HEATING ELECTRIC BATTERIES

### 16.8.1. Default configuration. Supply air fan on the left side

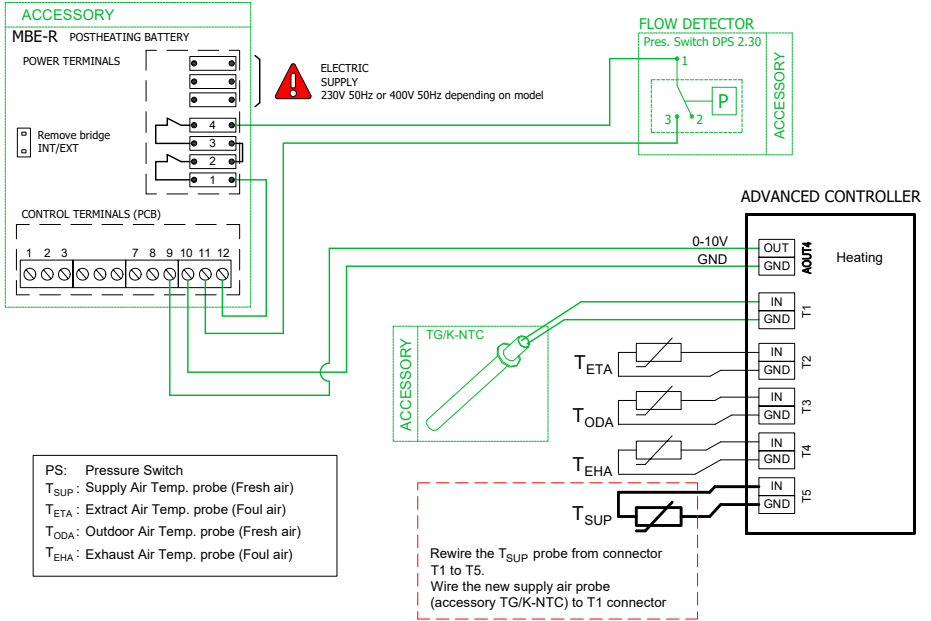

## 16.8.2. Symmetric configuration. Supply air fan on the right side

(see chapter “Exchanging the function of supply and extraction circuits”)

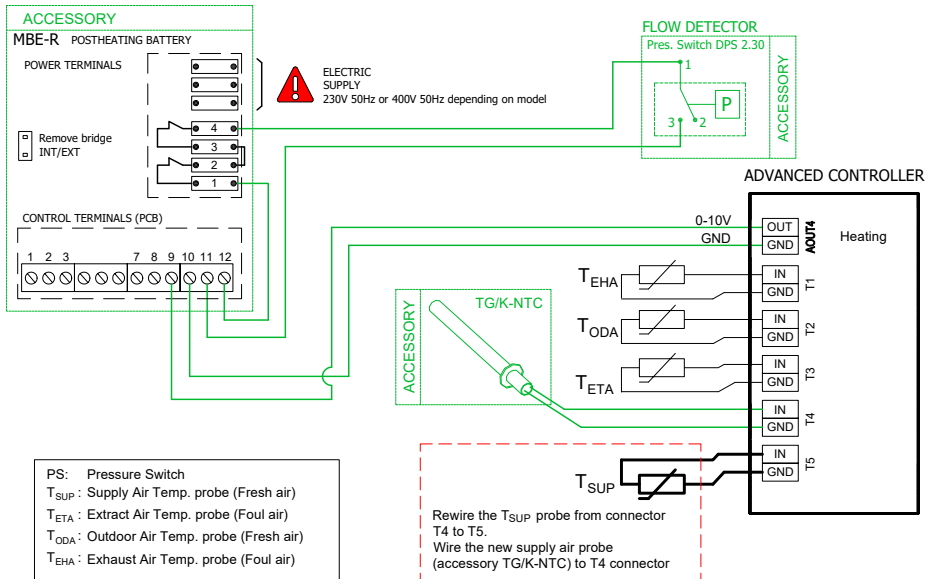

## 16.9. SPECIFIC WIRING TO CONTROL EXTERNAL ELECTRIC PREHEATING BATTERIES

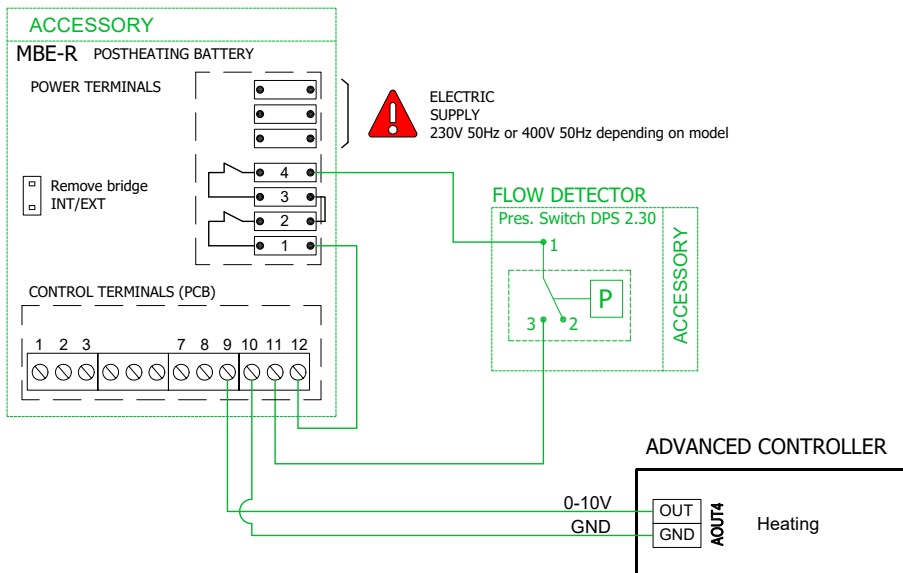



**S&P SISTEMAS DE VENTILACIÓN, S.L.U.**

C. Llevant, 4  
Polígono Industrial Llevant  
08150 Parets del Vallès  
Barcelona - España

Tel. +34 93 571 93 00  
[www.solerpalau.com](http://www.solerpalau.com)



Ref. 9023119400