

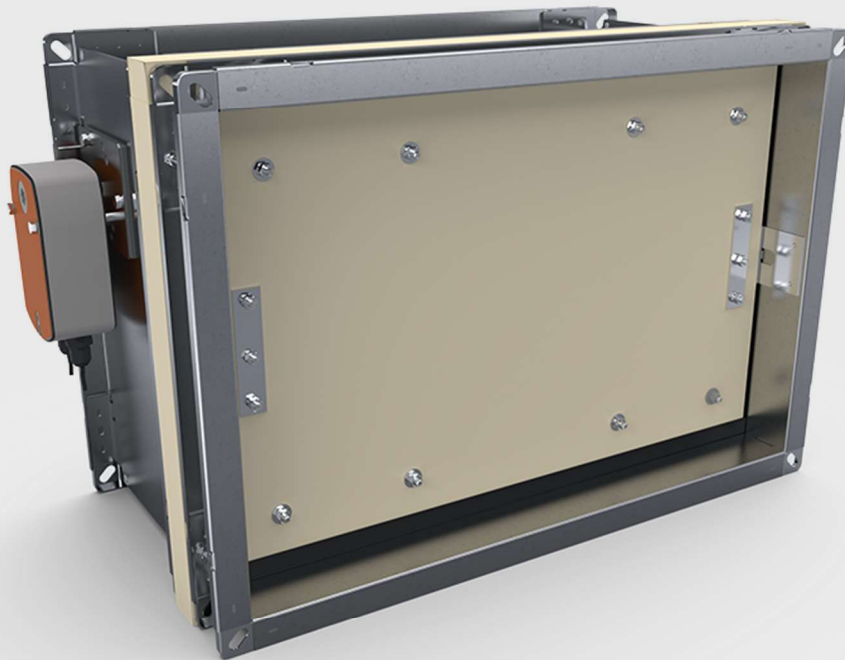

# KWP-P-E

Fire Damper -  
rectangular

## Technical Documentation



 <b>1488</b>	
<b>SMAY Sp. z o.o.</b> <b>22</b> <b>CSWU:1488-CPR-0437/W</b> <b>DWU: 001-CPR-2014</b>	
<b>EN 12101-8:2011</b> <b>Multi-zone fire damper</b>  type: KWP-P-E	
Nominal activation conditions/sensitivity: <b>Closing/opening during the test at the right time</b>	Automatic starting - Pass
<b>Response time/Closure time:</b>	Automatic starting - Pass
Reliability:	10 000 cycles.<120S
Fire resistance:	
<b>Fire integrity - E</b> <b>Fire insulation - I</b> <b>Smoke leakage - S</b> <b>Mechanical stability (under E)</b> <b>Maintenance of the cross section (under E)</b>	EI 120 (v <sub>ew</sub> h <sub>ow</sub> i↔o) S1500C <sub>10000</sub> AAmulti  EI 120 (v <sub>ed</sub> i↔o) S1000C <sub>10000</sub> AAmulti
Durability:	
<b>Maintenance of certainty operation with time delay</b>	Pass 10 000 cycles, <120S

Version 6.15

SMAY reserves the right to make changes to this document.

## TABLE OF CONTENT

1.	INTRODUCTION.....	3
2.	LEGAL REGULATIONS.....	3
3.	INTENDED USE.....	3
4.	TECHNICAL DESCRIPTION .....	4
5.	BELIMO ELECTRIC ACTUATORS USED IN KWP-P-E.....	7
6.	CONDITIONS OF TRANSPORT AND STORAGE .....	14
7.	INSTALLATION TECHNOLOGY.....	14
7.1.	INSTALLATION TECHNOLOGY – RIGID WALL.....	15
7.2.	INSTALLATION TECHNOLOGY - CEILING.....	19
7.3.	INSTALLATION TECHNOLOGY - DUCT.....	21
8.	INSTALLATION TECHNOLOGY FOR FIRE DAMPERS IN BATTERIES .....	22
9.	PRINCIPLES OF MAINTENANCE.....	32
10.	TERMS OF WARRANTY.....	34



## 1. INTRODUCTION

The purpose of technical documentation is to familiarize the user with the intended use, design, operation principle, installation, periodic maintenance and operation of product..

## 2. LEGAL REGULATIONS

The KWP-P-E fire dampers are certified by the Building Research Institute (ITB – Instytut Techniki Budowlanej). **Certificate of Constancy of Performance No. 1488-CPR- 0437/W** along with the attachment No. Z-1488-CPR-0437/W. The set of dampers has been awarded the National Technical Assessment No. **ITB-KOT-2020/1398 edition 2**.

The dampers are designed, manufactured and tested in accordance with the following standards: **PN-EN 12101-8** "Smoke and heat control systems – Part 8: Smoke control dampers" and **PN-EN 13501-4** "Fire classification of construction products and building elements – Part 4: Classification using data from fire resistance tests on components of smoke control systems."

The effectiveness of the dampers is confirmed by tests according to **PN-EN 1366-2** and **PN-EN 1366-10** "Fire resistance tests for service installations – Part 2: Fire dampers, Part 10: Smoke control dampers."

The KWP-P-E fire dampers are classified as tightness class C (housing tightness) devices on the basis of tests carried out according to **PN-EN 1751** "Ventilation for buildings. Air terminal devices. Aerodynamic testing of dampers and valves."

## 3. INTENDED USE

The KWP-P-E fire dampers are designed to be used in automatically activated fire ventilation system, to support both single fire zones and multiple fire zones. They are installed also in mixed type ventilation system, where they are performing the function of fire ventilation and general/comfort ventilation systems. In fire ventilation systems starting the fans follows after the damper goes to right position (open position in case the damper working in fire-zone, and closed position in case the damper working in other fire-zones).

Maximum overpressure in supply ventilation systems, included in the fire ventilation systems provided with a KWP-P-E is 500 Pa, while the maximum operating negative pressure in fire ventilation systems is 1500 Pa.

KWP-P-E fire dampers are classified in the following fire resistance range and can be mounted in the following building partitions:

- **EI 120 (v<sub>ew</sub>-h<sub>ow</sub>-i↔o) S1500C<sub>10000</sub> AAmulti**
- **EI 120 (v<sub>ed</sub>-i↔o) S1000C<sub>10000</sub> AAmulti**
  - concrete wall with thickness 115 mm or more,
  - brick walls having a thickness of 115 mm or more (masonry of solid brick, cellular concrete blocks),
  - concrete ceiling with thickness 150 mm or more,
  - on fire ventilation ducts.

Table 1. Table of fire resistance

Construction type	Minimum thickness of the building partitions mm	Fire resistance class	Sealing type
<b>Ceiling</b>	≥150 mm	EI 120 (h <sub>ow</sub> i↔o) S1500 C <sub>10 000</sub> AAmulti	MORTAR / MINERAL WOOL
<b>Rigid wall</b>	≥115 mm	EI 120 (v <sub>ew</sub> i↔o) S1500 C <sub>10 000</sub> AAmulti	MORTAR
<b>Duct</b>	-	EI 120 (v <sub>ed</sub> i↔o) S1000 C <sub>10 000</sub> AAmulti	CERAMIC GASKET, CONNECTION CLAMPS
<b>Battery</b>	≥150 for ≤6m2 ≥200 mm for >6m2	EI 120 (v <sub>ewd</sub> i↔o) S1000 C <sub>10 000</sub> AAmulti	MORTAR

where:

**E** – fire integrity,

**I** – fire insulation,

**120**– duration of fulfilment of E, I and S criteria, expressed in minutes,

**v<sub>ew</sub>** – damper mounted directly in the wall,

**h<sub>ow</sub>** – damper mounted directly in the ceiling,

**v<sub>ed</sub>** – damper mounted directly in the duct,

**i↔o** – operating effectiveness criteria are fulfilled from the inside to the outside (fire inside), and from the outside to the inside (fire outside).

**S** – smoke leakage,

**1500** – allowable negative pressure in the installation, in pascals,

**C<sub>10000</sub>** – the suitability of the damper for use in combined smoke control and general ventilation systems,

**AA** – automatic starting,

**multi** – acceptable installation in installations serving more than one fire zone.

KWP-P-E fire dampers may be installed in vertical building partitions with both **horizontal and vertical rotation axis** of baffle, the damper may be rotated in a way enabling on location of actuator on left or right side and on top or bottom.

KWP-P-E fire dampers are intended for installation on internal and external building partition and also on fire ventilation ducts. In case of external wall insulation there is required to use the damper with increased anti-corrosion properties and with finishing element (intake or launcher), which will protect from influence of atmospheric factors. Drive system (actuator or spring mechanism) should be installed inside facility.

#### 4. TECHNICAL DESCRIPTION

KWP-P-E fire dampers comprise with two steel housing, rectangular in profile, separated by isolating divider, moving, single-plane baffle and drive mechanism.

The damper housing and its interacting elements are made of galvanized steel sheet. Both ends of the housing are terminated with connection flanges, allowing easy connection between the duct and the damper.

There is intumescent seal on the inner surface of the housing, in the place of perforation around the closed isolating baffle. Its characteristic feature is the fact that their volume increases at high temperatures, tightly filling all leaks between the baffle and the body. Between housing and insulating spacer there is foamed rubber gasket, ensuring the tightness integrity in the ambient temperature.

The isolating baffle of the damper is made of calcium-silica board, and a aluminum tape is installed on its perimeter, ensuring reduction of friction.

Baffle is rotating on two steel axles located in housing. Baffle movement is limited in the closed position by a stop bar.

KWP-P-E damper is equipped with an electric actuator of the BEN, BLE, BEE or BE series from BELIMO, which constitutes a system Damper drive with a supply voltage of AC 230 V or AC/DC 24 V. After voltage is supplied, the actuator rotates the baffle into the open position.

The actuators are moving in both directions by the voltage given to the individual circuits – actuators do not have return spring and thermal fuse. The dampers can be made with an inspection cover in accordance with the order code.

During normal operation of the system, KWP-P-E dampers are in closed position. If a fire breaks out, the damper's baffle rotates to an open position, or stays closed.

The type series of the dampers covers the following dimensions: clear damper width **from 200 to 1500 mm** (50 mm intervals) and clear damper height **from 200 to 1000 mm** (50 mm intervals), with a maximum cross-sectional area for KWP-P-E totals 1,5 m<sup>2</sup>. Length of standard edition of KWP-P-E damper is L=350 [mm] (optional L=600 [mm]).

For special request KWP-P dampers could be made in 10 [mm] interval dimension.

Table 2. Type series of damper dimension KWP-P-E

KWP-P	Width B [mm]																										
	200	250	300	350	400	450	500	550	600	650	700	750	800	850	900	950	1000	1050	1100	1150	1200	1250	1300	1350	1400	1450	1500
200	0,027	0,035	0,042	0,049	0,056	0,064	0,071	0,078	0,085	0,093	0,100	0,107	0,114	0,122	0,129	0,136	0,143	0,151	0,158	0,165	0,172	0,180	0,187	0,194	0,201	0,209	0,216
250	0,037	0,046	0,056	0,066	0,076	0,085	0,095	0,105	0,115	0,124	0,134	0,144	0,154	0,163	0,173	0,183	0,193	0,202	0,212	0,222	0,232	0,241	0,251	0,261	0,271	0,280	0,290
300	0,046	0,058	0,070	0,083	0,095	0,107	0,119	0,132	0,144	0,156	0,168	0,181	0,193	0,205	0,217	0,230	0,242	0,254	0,266	0,279	0,291	0,303	0,315	0,328	0,340	0,352	0,364
350	0,055	0,070	0,085	0,099	0,114	0,129	0,144	0,158	0,173	0,188	0,203	0,217	0,232	0,247	0,262	0,276	0,291	0,306	0,321	0,335	0,350	0,365	0,380	0,394	0,409	0,424	0,439
400	0,064	0,082	0,099	0,116	0,133	0,151	0,168	0,185	0,202	0,220	0,237	0,254	0,271	0,289	0,306	0,323	0,340	0,358	0,375	0,392	0,409	0,427	0,444	0,461	0,478	0,496	0,513
450	0,074	0,093	0,113	0,133	0,153	0,172	0,192	0,212	0,232	0,251	0,271	0,291	0,311	0,330	0,350	0,370	0,390	0,409	0,429	0,449	0,469	0,488	0,508	0,528	0,548	0,567	0,587
500	0,083	0,105	0,127	0,150	0,172	0,194	0,216	0,239	0,261	0,283	0,305	0,328	0,350	0,372	0,394	0,417	0,439	0,461	0,483	0,506	0,528	0,550	0,572	0,595	0,617	0,639	0,661
550	0,092	0,117	0,142	0,166	0,191	0,216	0,241	0,265	0,290	0,315	0,340	0,364	0,389	0,414	0,439	0,463	0,488	0,513	0,538	0,562	0,587	0,612	0,637	0,661	0,686	0,711	0,736
600	0,101	0,129	0,156	0,183	0,210	0,238	0,265	0,292	0,319	0,347	0,374	0,401	0,428	0,456	0,483	0,510	0,537	0,565	0,592	0,619	0,646	0,674	0,701	0,728	0,755	0,783	0,810
650	-	0,140	0,170	0,200	0,230	0,259	0,289	0,319	0,349	0,378	0,408	0,438	0,468	0,497	0,527	0,557	0,587	0,616	0,646	0,676	0,706	0,735	0,765	0,795	0,825	0,854	0,884
700	-	0,152	0,184	0,217	0,249	0,281	0,313	0,346	0,378	0,410	0,442	0,475	0,507	0,539	0,571	0,604	0,636	0,668	0,700	0,733	0,765	0,797	0,829	0,862	0,894	0,926	0,958
750	-	0,164	0,199	0,233	0,268	0,303	0,338	0,372	0,407	0,442	0,477	0,511	0,546	0,581	0,616	0,650	0,685	0,720	0,755	0,789	0,824	0,859	0,894	0,928	0,963	0,998	1,033
800	-	-	0,213	0,250	0,287	0,325	0,362	0,399	0,436	0,474	0,511	0,548	0,585	0,623	0,660	0,697	0,734	0,772	0,809	0,846	0,883	0,921	0,958	0,995	1,032	1,070	1,107
850	-	-	0,227	0,267	0,307	0,346	0,386	0,426	0,466	0,505	0,545	0,585	0,625	0,664	0,704	0,744	0,784	0,823	0,863	0,903	0,943	0,982	1,022	1,062	1,102	1,141	1,181
900	-	-	0,241	0,284	0,326	0,368	0,410	0,453	0,495	0,537	0,579	0,622	0,664	0,706	0,748	0,791	0,833	0,875	0,917	0,960	1,002	1,044	1,086	1,129	1,171	1,213	1,255
950	-	-	-	0,300	0,345	0,390	0,435	0,479	0,524	0,569	0,614	0,658	0,703	0,748	0,793	0,837	0,882	0,927	0,972	1,016	1,061	1,106	1,151	1,195	1,240	1,285	1,330
1000	-	-	-	0,317	0,364	0,412	0,459	0,506	0,553	0,601	0,648	0,695	0,742	0,790	0,837	0,884	0,931	0,979	1,026	1,073	1,120	1,168	1,215	1,262	1,309	1,357	1,404
1050	-	-	-	0,334	0,384	0,433	0,483	0,533	0,583	0,632	0,682	0,732	0,782	0,831	0,881	0,931	0,981	1,030	1,080	1,130	1,180	1,229	1,279	1,329	1,379	-	-
1100	-	-	-	-	0,403	0,455	0,507	0,560	0,612	0,664	0,716	0,769	0,821	0,873	0,925	0,978	1,030	1,082	1,134	1,187	1,239	1,291	1,343	1,396	-	-	-
1150	-	-	-	-	0,422	0,477	0,532	0,586	0,641	0,696	0,751	0,805	0,860	0,915	0,970	1,024	1,079	1,134	1,189	1,243	1,298	1,353	1,408	-	-	-	-
1200	-	-	-	-	0,441	0,499	0,556	0,613	0,670	0,728	0,785	0,842	0,899	0,957	1,014	1,071	1,128	1,186	1,243	1,300	1,357	1,415	-	-	-	-	-
1250	-	-	-	-	-	0,520	0,580	0,640	0,700	0,759	0,819	0,879	0,939	0,998	1,058	1,118	1,178	1,237	1,297	1,357	1,417	-	-	-	-	-	-
1300	-	-	-	-	-	0,542	0,604	0,667	0,729	0,791	0,853	0,916	0,978	1,040	1,102	1,165	1,227	1,289	1,351	1,414	-	-	-	-	-	-	-
1350	-	-	-	-	-	0,564	0,629	0,693	0,758	0,823	0,888	0,952	1,017	1,082	1,147	1,211	1,276	1,341	1,406	-	-	-	-	-	-	-	-
1400	-	-	-	-	-	-	0,653	0,720	0,787	0,855	0,922	0,989	1,056	1,124	1,191	1,258	1,325	1,393	-	-	-	-	-	-	-	-	-
1450	-	-	-	-	-	-	0,677	0,747	0,817	0,886	0,956	1,026	1,096	1,165	1,235	1,305	1,375	-	-	-	-	-	-	-	-	-	-
1500	-	-	-	-	-	-	0,701	0,774	0,846	0,918	0,990	1,063	1,135	1,207	1,279	1,352	1,424	-	-	-	-	-	-	-	-	-	-

BEN actuators are used for the damper clear area of  $P \leq 1,2$  [m<sup>2</sup>],  
 BEE actuators are used for the damper clear area of  $1,2$  [m<sup>2</sup>] <  $P \leq 1,3$  [m<sup>2</sup>], and when  $H \leq 1200$  [mm]  
 BE actuators are used for the damper clear area  $P > 1,3$  [m<sup>2</sup>], or when  $H > 1200$  [mm]

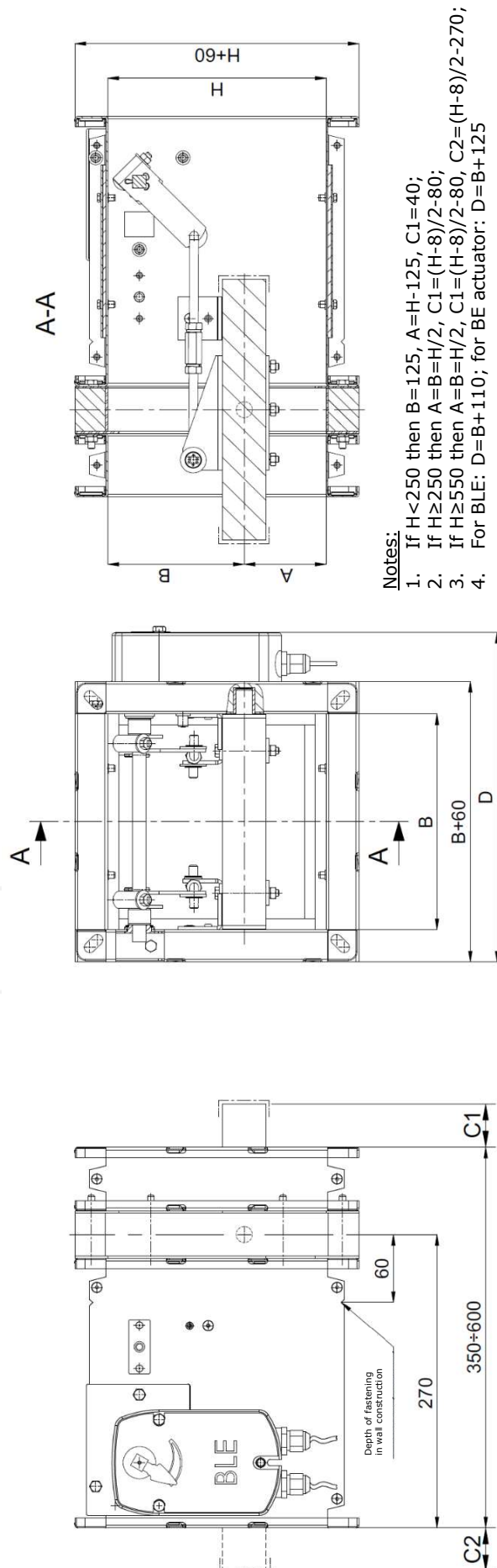

Figure 1. KWP-P-E damper

Table 3. KWP-P-E weight [kg]

H/B	200	300	400	500	600	700	800	900	1000	1100	1200	1300	1400	1500
Fire damper weight KWP [kg]														
200	12,4	14,6	16,8	19,0	21,2	23,4	25,6	27,8	30,0	32,2	34,4	41,4	44,0	46,5
300	14,4	17,0	19,7	22,2	24,9	27,5	30,1	32,7	35,4	38,0	40,6	48,3	51,2	54,2
400	16,6	19,6	22,6	25,6	28,6	31,6	34,7	37,7	40,7	43,8	46,8	55,2	58,6	61,9
500	18,7	22,1	25,6	29,0	32,4	35,8	39,3	42,7	46,1	49,5	52,9	62,2	65,9	69,6
600	20,7	24,6	28,5	32,2	36,1	39,9	43,8	47,6	51,4	55,2	59,1	69,0	73,2	77,3
700	-	27,1	31,4	35,5	39,8	44,0	48,3	52,5	56,7	61,0	65,2	75,9	80,4	85,0
800	-	29,6	34,3	38,8	43,5	48,1	52,8	57,4	62,1	66,7	71,3	82,8	87,7	92,7
900	-	32,1	37,1	42,1	47,2	52,2	57,3	62,3	67,4	72,4	77,5	89,6	96,2	101,5
1000	-	-	40,1	45,5	51,0	56,4	61,9	67,4	72,8	78,2	83,7	97,8	103,6	109,3
1100	-	-	43,2	48,9	54,8	60,7	66,5	72,4	78,2	84,1	90,2	104,6	-	-
1200	-	-	46,2	52,3	58,7	64,9	71,1	77,5	83,7	90,0	104,5	-	-	-
1300	-	-	-	61,6	68,6	75,6	82,6	89,6	97,8	104,4	-	-	-	-
1400	-	-	-	65,3	72,8	80,1	87,5	96,2	103,6	-	-	-	-	-
1500	-	-	-	69,0	76,9	84,7	92,5	101,5	109,3	-	-	-	-	-

## 5. BELIMO ELECTRIC ACTUATORS USED IN KWP-P-E

### Actuator BEN series:

- BEN230,
- BEN24,
- BEN24-ST.

where:  
ST - connection plug



### Actuator BEE series:

- BEE230,
- BEE24,
- BEE24-ST.

where:  
ST - connection plug.



### Actuator BE series:

- BE230,
- BE24,
- BE24-ST.

where:  
ST - connection plug.





**Wiring diagram BEN230, BEE230 and BE230:**
**BEN230:**

AC 230 V, open-close

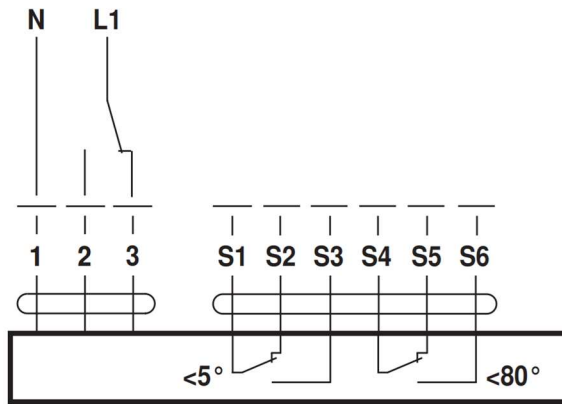
**BEE230:**

AC 230 V, open-close

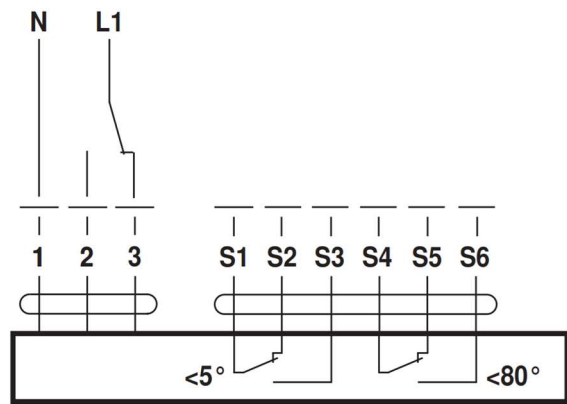

**BE230:**

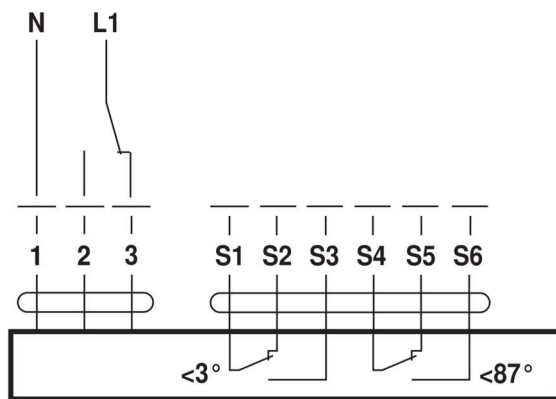
AC 230 V, open-close

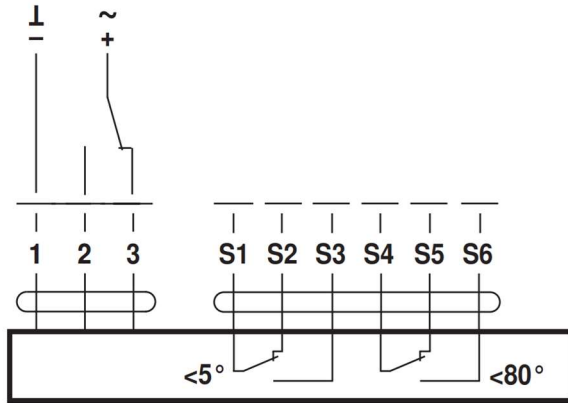

**Wiring diagram BEN24, BEE24 and BE24:**
**BEN24:**

AC/DC 24 V, open-close

**BEE24:**

AC/DC 24 V, open-close

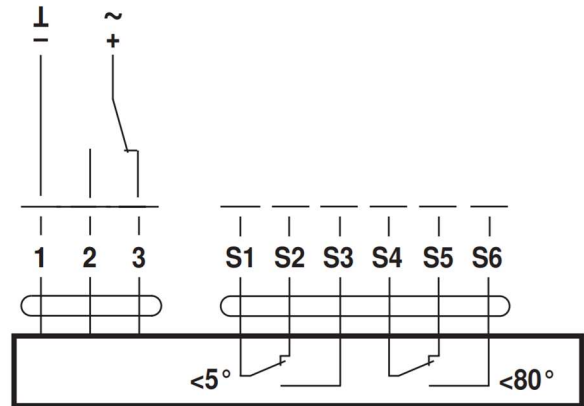
**BE24:**

AC/DC 24 V, open-close

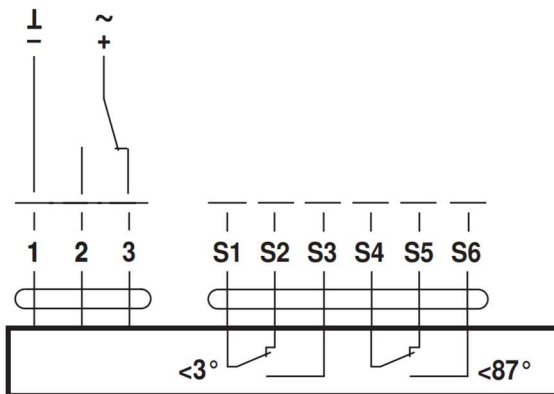

**Wiring diagram BEN24-ST, BEE24-ST and BE24-ST:**

**BEN24-ST:**

Application with connector plug

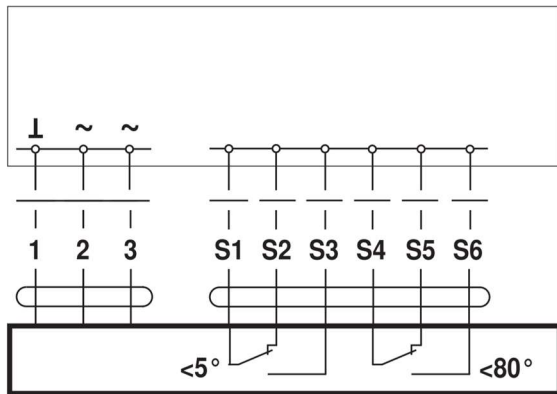

**BEE24-ST:**

Application with connector plug

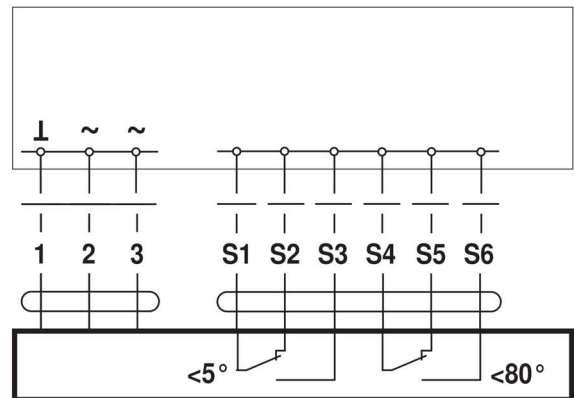

**BE24-ST:**

Application with SBSE-Control

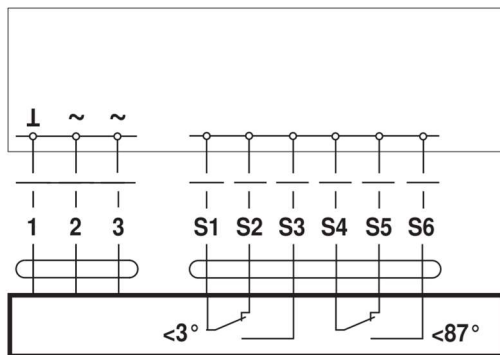

<b>Technical data:</b>	<b>BEN230</b>	<b>BEN24 (-ST)</b>
Nominal voltage	AC 230 V	AC/DC 24 V
Nominal voltage frequency	50/60 Hz	50/60 Hz
Nominal voltage range	AC 198...264 V	AC 19.2...28.8 V / DC 21.6...28.8 V
Switching thresholds min. ON voltage	AC 198V	AC 19.2 V / DC 21.6 V
Switching thresholds max. OFF voltage	AC 50 V	AC 5 V / DC 7 V
Power consumption in operation	4 W	3 W
Power consumption in rest position	0.4 W	0.1 W
Power consumption for wire sizing	7 VA	6 VA
Power consumption for wire sizing note	I <sub>max</sub> 4 A @ 5 ms	I <sub>max</sub> 8.2 A @ 5 ms
Auxiliary switch	2 x SPDT	2 x SPDT
Switching capacity auxiliary switch	1 mA...3 (0.5 inductive) A, AC 250 V	1 mA...3 (0.5 inductive) A, AC 250 V
Switching points auxiliary switch	5° / 80°	5° / 80°
Tolerance	±3°	±3°
Connection supply / control	Cable 1 m, 3 x 0.75 mm <sup>2</sup> , halogen-free	Cable 1 m, 3 x 0.75 mm <sup>2</sup> , halogen-free
Connection auxiliary switch	Cable 1 m, 6 x 0.75 mm <sup>2</sup> , halogen-free	Cable 1 m, 6 x 0.75 mm <sup>2</sup> , halogen-free
Nominal torque	15 Nm	15 Nm
Direction of rotation motor	can be selected by mounting	can be selected by mounting
Manual override	with hand crank	with hand crank
Angle of rotation	Max. 95°	Max. 95°
Running time motor	<30s / 90°	<30s / 90°
Sound power level, motor	58 dB(A)	58 dB(A)
Spindle driver	Form fit 12x12 mm, Continuous hollow shaft	Form fit 12x12 mm, Continuous hollow shaft
Position indication	Mechanically, with pointer	Mechanically, with pointer
Service life	Min. 10,000 cycles	Min. 10,000 cycles
Protection class IEC/EN	II reinforced insulation	III Safety Extra-Low Voltage (SELV)
Protection class auxiliary switch IEC/EN	II reinforced insulation	II reinforced insulation
Degree of protection IEC/EN	IP54	IP54
EMC	CE according to 2014/30/EU	CE according to 2014/30/EU
Low voltage directive	CE according to 2014/35/EU	CE according to 2014/35/EU
Certification IEC/EN	IEC/EN 60730-1 and IEC/EN 60730-2-14	IEC/EN 60730-1 and IEC/EN 60730-2-14
Mode of operation	Type 1.B	Type 1.B
Rated impulse voltage supply / control	4 kV	0.8 kV
Rated impulse voltage auxiliary switch	4 kV	4 kV
Control pollution degree	3	3
Ambient temperature	-30...55 °C	-30...55 °C
Non-operating temperature	-40...80 °C	-40...80 °C
Ambient humidity	Max. 95% r.h., non-condensing	Max. 95% r.h., non-condensing
Maintenance	Maintenance-free	Maintenance-free
Weight	0.9 kg	0.9 kg

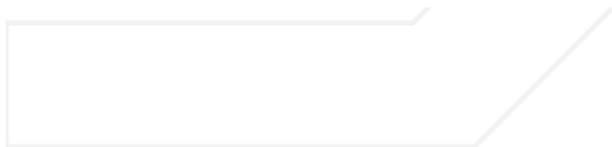

**Technical data:**

	<b>BEE230</b>	<b>BEE24 (-ST)</b>
Nominal voltage	AC 230 V	AC/DC 24 V
Nominal voltage frequency	50/60 Hz	50/60 Hz
Nominal voltage range	AC 198...264 V	AC 19.2...28.8 V / DC 21.6...28.8 V
Switching thresholds min. ON voltage	AC 198V	AC 19.2 V / DC 21.6 V
Switching thresholds max. OFF voltage	AC 50 V	AC 5 V / DC 7 V
Power consumption in operation	3.5 W	2.5 W
Power consumption in rest position	0.4 W	0.1 W
Power consumption for wire sizing	6 VA	5 VA
Power consumption for wire sizing note	I <sub>max</sub> 4 A @ 5 ms	I <sub>max</sub> 8.2 A @ 5 ms
Auxiliary switch	2 x SPDT	2 x SPDT
Switching capacity auxiliary switch	1 mA...3 (0.5 inductive) A, AC 250 V	1 mA...3 (0.5 inductive) A, AC 250 V
Switching points auxiliary switch	5° / 80°	5° / 80°
Tolerance	±3°	±3°
Connection supply / control	Cable 1 m, 3 x 0.75 mm <sup>2</sup> , halogen-free	Cable 1 m, 3 x 0.75 mm <sup>2</sup> , halogen-free
Connection auxiliary switch	Cable 1 m, 6 x 0.75 mm <sup>2</sup> , halogen-free	Cable 1 m, 6 x 0.75 mm <sup>2</sup> , halogen-free
Nominal torque	25 Nm	25 Nm
Direction of rotation motor	can be selected by mounting	can be selected by mounting
Manual override	with hand crank	with hand crank
Angle of rotation	Max. 95°	Max. 95°
Running time motor	<60s / 90°	<60s / 90°
Sound power level, motor	58 dB(A)	58 dB(A)
Spindle driver	Form fit 12x12 mm, Continuous hollow shaft	Form fit 12x12 mm, Continuous hollow shaft
Position indication	Mechanically, with pointer	Mechanically, with pointer
Service life	Min. 10,000 cycles	Min. 10,000 cycles
Protection class IEC/EN	II reinforced insulation	III Safety Extra-Low Voltage (SELV)
Protection class auxiliary switch IEC/EN	II reinforced insulation	II reinforced insulation
Degree of protection IEC/EN	IP54	IP54
EMC	CE according to 2014/30/EU	CE according to 2014/30/EU
Low voltage directive	CE according to 2014/35/EU	CE according to 2014/35/EU
Certification IEC/EN	IEC/EN 60730-1 and IEC/EN 60730-2-14	IEC/EN 60730-1 and IEC/EN 60730-2-14
Mode of operation	Type 1.B	Type 1.B
Rated impulse voltage supply / control	4 kV	0.8 kV
Rated impulse voltage auxiliary switch	4 kV	4 kV
Control pollution degree	3	3
Ambient temperature	-30...55 °C	-30...55 °C
Non-operating temperature	-40...80 °C	-40...80 °C
Ambient humidity	Max. 95% r.h., non-condensing	Max. 95% r.h., non-condensing
Maintenance	Maintenance-free	Maintenance-free
Weight	1.1 kg	1.1 kg



<b>Technical data:</b>	<b>BE230</b>	<b>BE24 (-ST)</b>
Nominal voltage	AC 230 V	AC/DC 24 V
Nominal voltage frequency	50/60 Hz	50/60 Hz
Nominal voltage range	AC 198...264 V	AC 19.2...28.8 V / DC 21.6...28.8 V
Switching thresholds min. ON voltage	AC 198 V	AC 19.2 V / DC 21.6 V
Switching thresholds max. OFF voltage	AC 100 V	AC 6.5 V / DC 6.5 V
Power consumption in operation	8 W	12 W
Power consumption in rest position	0.5 W	0.5 W
Power consumption for wire sizing	15 VA	18 VA
Power consumption for wire sizing note	I <sub>max</sub> 7.9 A @ 5 ms	I <sub>max</sub> 8.2 A @ 5 ms
Auxiliary switch	2 x SPDT	2 x SPDT
Switching capacity auxiliary switch	1 mA...6 (3) A, DC 5 V...AC 250 V (II Protective insulated)	1 mA...6 (3) A, DC 5 V...AC 250 V (II Protective insulated)
Switching points auxiliary switch	3° / 87° (in relation to 0...90°)	3° / 87° (in relation to 0...90°)
Tolerance	±2°	±2°
Connection supply	Cable 1 m, 3 x 0.75 mm <sup>2</sup> , halogen-free	Cable 1 m, 3 x 0.75 mm <sup>2</sup> , halogen-free
Connection auxiliary switch	Cable 1 m, 6 x 0.75 mm <sup>2</sup> , halogen-free	Cable 1 m, 6 x 0.75 mm <sup>2</sup> , halogen-free
Torque motor	Min. 40 Nm	Min. 40 Nm
Inhibiting torque dynamic	40 Nm	40 Nm
Inhibiting torque static (voltage-free)	50 Nm	50 Nm
Direction of rotation motor	Can be selected by mounting L/R	Can be selected by mounting L/R
Angle of rotation	100° (including 5° mechanical overrun at both sides)	Max. 100° (including 5° mechanical overrun at both sides)
Running time motor	<60 s / 90°	<60 s / 90°
Sound power level motor	62 dB(A)	62 dB(A)
Spindle driver	Form fit 14 mm	Form fit 14 mm
Position indication	Mechanically, with pointer	Mechanically, with pointer
Service life	Min. 10,000 cycles	Min. 10,000 cycles
Protection class IEC/EN	II Protective insulated	III Safety extra-low voltage
Degree of protection IEC/EN	IP54	IP54
EMC	CE according to 2004/108/EC	CE according to 2004/108/EC
Low voltage directive	CE according to 2006/95/EC	CE according to 2006/95/EC
Certification IEC/EN	IEC/EN 60730-1 and IEC/EN 60730-2-14	IEC/EN 60730-1 and IEC/EN 60730-2-14
Mode of operation	Type 1.B	Type 1.B
Rated impulse voltage supply	4 kV	0.8 kV
Rated impulse voltage auxiliary switch	2.5 kV	2.5 kV
Control pollution degree	3	3
Ambient temperature	-30...50°C	-30...50°C
Non-operating temperature	-40...80°C	-40...80°C
Ambient humidity	95% r.h., non-condensing	95% r.h., non-condensing
Maintenance	Maintenance-free	Maintenance-free
Weight	2.7 kg	2.7 kg

## 6. CONDITIONS OF TRANSPORT AND STORAGE

Fire dampers KWP-P-E should be stored in cardboard boxes and/or on pallets. Dampers should have a pre-protected actuator cardboard box. Fire dampers should be stored indoors, providing protection against atmospheric agents, at a minimum temperature of +5°C.

Do not allow mechanical damage of damper, that may be caused e.g. blows or dropping.

During the transport the dampers should be package in cardboard, and/or put on a pallets and should be secured before relocating, and against weather conditions.

After each transport, visual inspection of each fire damper must be carried out.

## 7. INSTALLATION TECHNOLOGY

Before installing fire dampers, check whether the damper has been damaged during transport or storage.

Place the damper straight on a flat surface and check that the damper opens and closes properly throughout its full range of motion. Opening and full closing must be smooth, and the movement of rotating elements must not be hindered. If the damper partition is blocked, further installation is not allowed. In the case of dampers with an actuator, open the damper with the key attached to the actuator. Do not pull the damper by its partition to open/close, this may cause permanent damage to the device which is not covered by the warranty.

The damper must be protected with covering material before montage, so it will be protected from soiling, and consequently damaging the elements of the damper.

ATTENTION: Distance between fire dampers or fire damper and construction elements must be compatible with standard 1366-2:

- a. Minimal 200 mm between fire damper, which are installed in different ventilating wires,
- b. Minimal 75 mm between fire damper and construction element (wall/ceiling).

Before installing fire dampers please read assembly technology recommended by the manufacturer. The way of installing recommended by one manufacturer may not be the same for other dampers. Recommended material and dimensions of the openings follow from experience from conducted research. Moreover, in rectangular dampers, it is necessary to use assembly wedges and a spacer to protect the body against compression during assembly.

Squeezing the housing can change the dimensions of slot between baffle and housing, correct dimensions of this slot is needed to keep correct way of opening and closing the damper. Correct preparation of the damper for installation is presented on the figure 2 and figure 3.



Figure 2. Correct preparation of the damper for installation (using spreader securing the housing)



Figure 3. Correct preparation of the damper for installation (using mounting wedge)

**ATTENTION:**

- a. The damper must be installed in such way, that the axis of baffle must be in horizontal or vertical position,
- b. Damper can not be used as formwork for the wall,
- c. Ventilation ducts should be installed that they cannot put any load on the damper, their suspension must ensure their full load capacity,
- d. The suspensions of the ventilation ducts connected to the dampers batteries must be made in accordance with the instruction of the manufacturer of ventilation ducts,
- e. In place of Z1 and Z2 suspensions, which are installed for the time of assembly of the damper and in place of mortar binding, it is possible to use mounting brackets, paying attention to the immobilization of the damper.

### 7.1. INSTALLATION TECHNOLOGY – RIGID WALL

- a. Make an opening in the wall with the 100 [mm] (acceptable  $80 \div 120$  [mm]) greater than the nominal dimensions of the fire damper =  $B+100$  and  $H+100$ .
- b. Put the closed fire damper into the installation opening on the depth marked by undercuts on the damper body (dimension 60 mm), from one side fix it with suspension Z1, and from other side fix it to the ventilation duct on Z2 suspension.
- c. After setting the fire damper as described, fill the gap between the fire damper and the wall with cement, cement-lime mortar, concrete, or PROMASTOP MG III of production of the PROMAT company.
- d. After 48 hours from the installation, the suspensions and supports used during installation of the fire damper, may be removed.



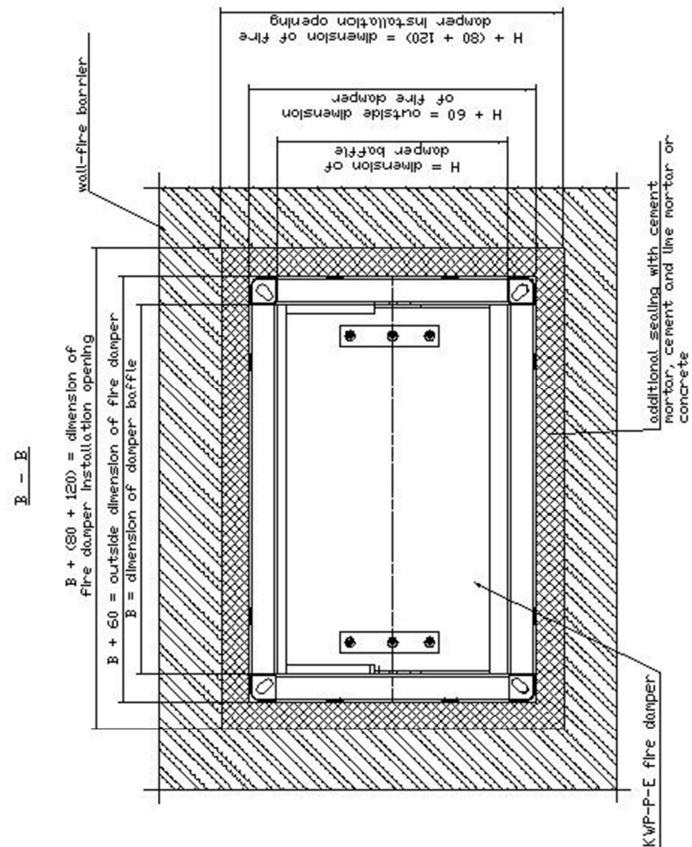
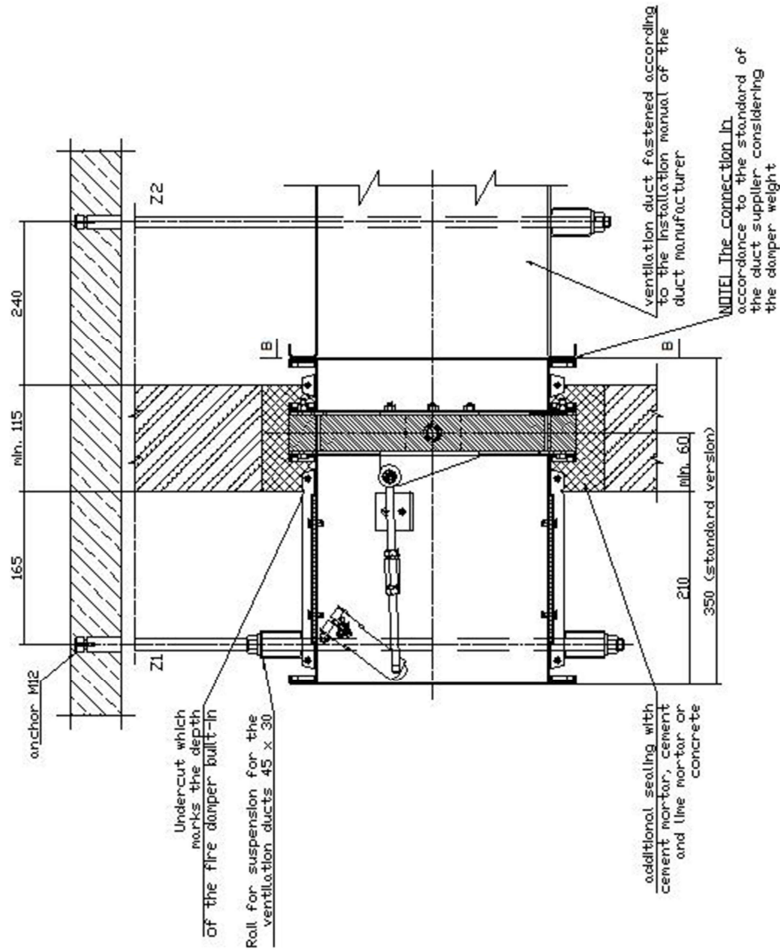
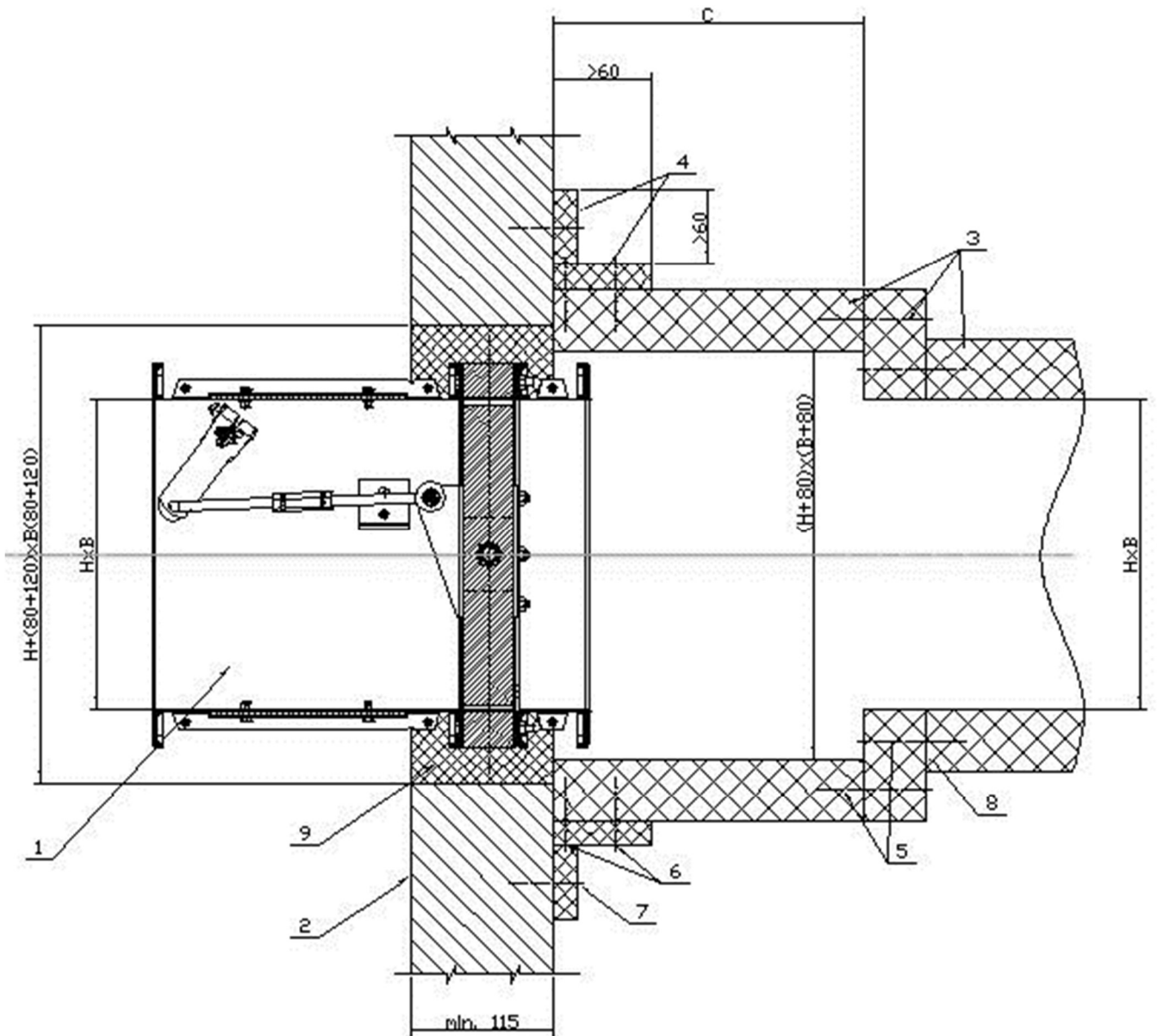
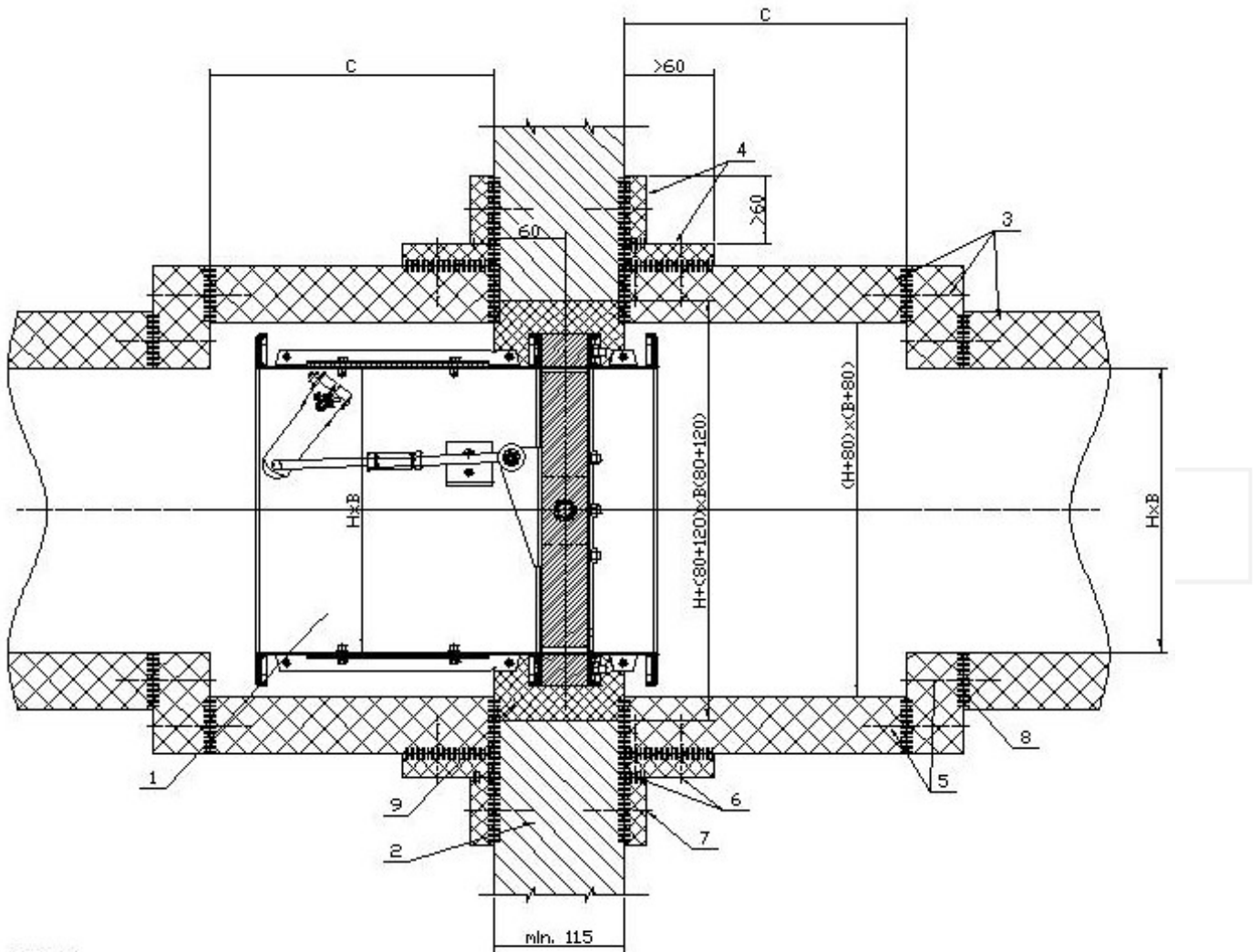

Figure 4. Installation method of fire dampers KWP-P in rigid wall

**NOTES:**

1. Smoke control damper KWP-P-E,
2. Wall, fire compartment,
3. PROMATECT L500 50mm,
4. PROMATECT -H 20mm,
5. Countersunk screw. UNIX 6x90,  $\alpha=200$ ,
6. Countersunk screw. UNIX 4x35,  $\alpha=200$ ,
7. Mounting anchor FPX M8,  $\alpha=200$ ,
8. PROMAT K-84 glue,
9. Cement mortar, cement and lime mortar or concrete  
 $C=H/2-50\text{mm}$ ,

Figure 5. Installation method of the damper in rigid wall with one-sidedly connected self-supporting smoke extract duct.

**NOTES:**

1. Smoke control damper KWP-P-E,
2. Wall, fire compartment,
3. PROMATECT L500 50mm,
4. PROMATECT -H 20mm,
5. Countersunk screw, UNIX 6x90;  $\alpha=200$ ,
6. Countersunk screw, UNIX 4x35;  $\alpha=200$ ,
7. Mounting anchor FPX MS1;  $\alpha=200$ ,
8. PROMAT K-84 glue,
9. Cement mortar, cement and lime mortar or concrete  
 $C=H/2-50\text{mm}$

Figure 6. Installation method of the damper in rigid wall with one-sidedly connected self-supporting smoke extract duct connected on both sides.

## 7.2. INSTALLATION TECHNOLOGY - CEILING

- a. Make an opening in the ceiling with the 100 [mm] (acceptable  $80 \div 120$  [mm]) greater than the nominal dimensions of the fire damper =  $B+100$  and  $H+100$ . In case of other dimensions than  $B+100 \times H+100$ , adjust dimensions of mounting brackets.
- b. Put the closed fire damper into the wall on the depth marked by undercuts on the damper body (dimension 60mm)
- c. After setting the fire damper as described, with use mounting brackets, fill the gap between the fire damper and the wall with cement, cement-lime mortar, concrete or with use mineral wool with density greater than  $100\text{kg/m}^3$  (item 1).
- d. Mount the mounting brackets properly:
  - a. Side length up to 500 mm – 1 pcs.
  - b. Side length from 500 to 800 mm – 2 pcs.

### PROMAT self-supporting duct:

- e. Make the duct with 50 mm thick PROMATECT-L500 panels (item 3).
- f. Make a band around the duct with 50 mm thick, 60 mm width PROMATECT-L500 panels (item 4).
- g. Make a band around the duct (under ceiling) with 20 mm thick, 200 mm width PROMATECT-H (item 5). \*This band is required only when mineral wool was used to seal the damper in point 3.
- h. Make a connection between the duct and ceiling likewise the duct with the band using glue K84.
- i. Connect the sides of the channel and sides the band with use screws  $4.2 \times 90$  -  $4.8 \times 120$ .
- j. Housing montage with actuator similarly as in the picture. Only the length of the mounting brackets will change. Mount the mounting brackets to the ceiling using raw bolts.

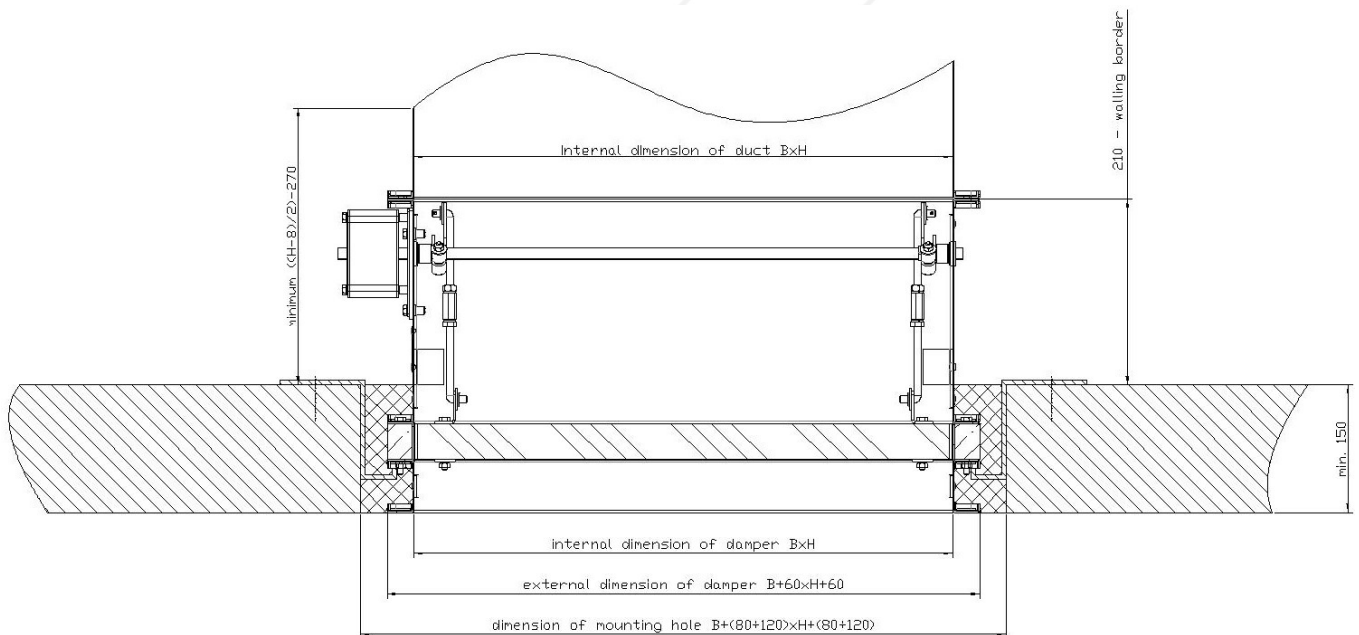

Figure 7. Installation method of fire dampers KWP-P in ceiling with a fire ventilation duct with sealing of cement mortar

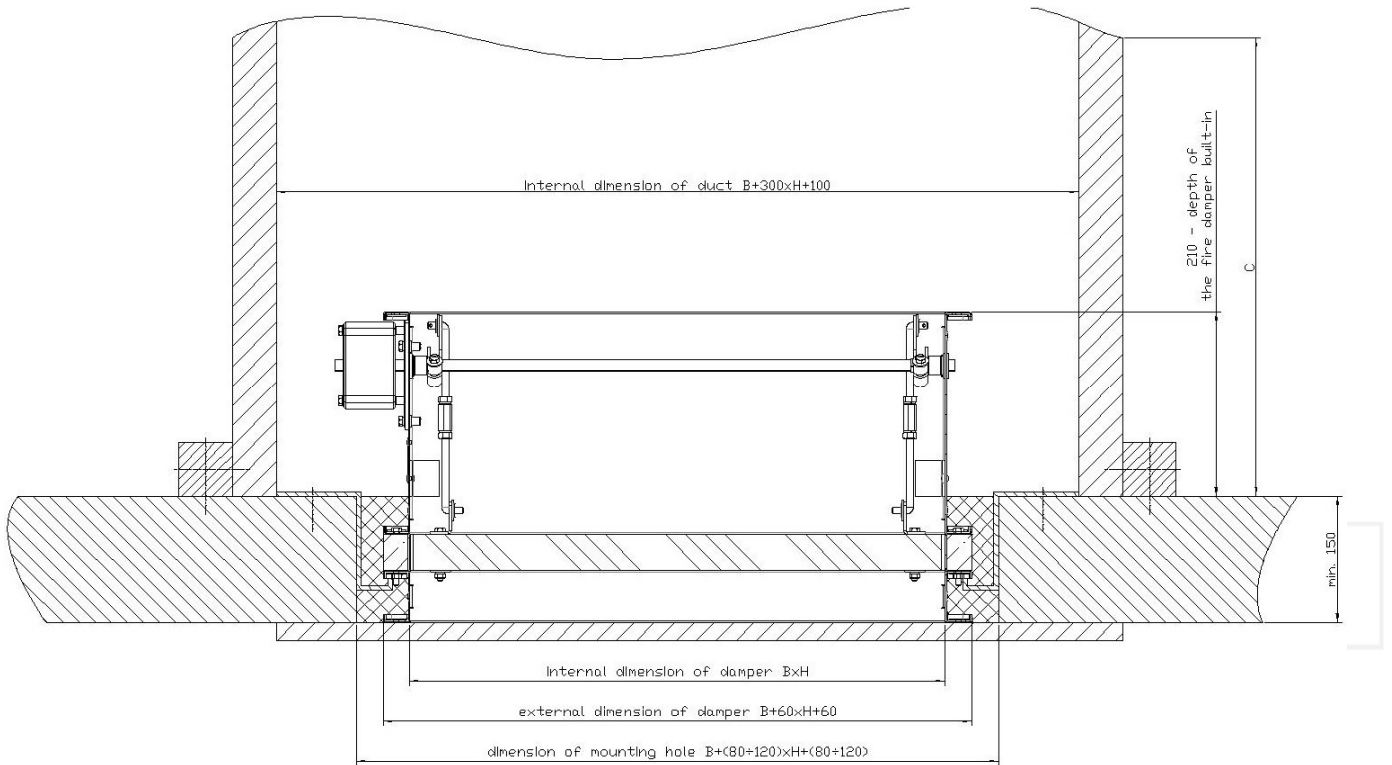

Figure 7. Installation method of fire dampers KWP-P in ceiling with a duct made of PROMAT boards with sealing of mineral wool

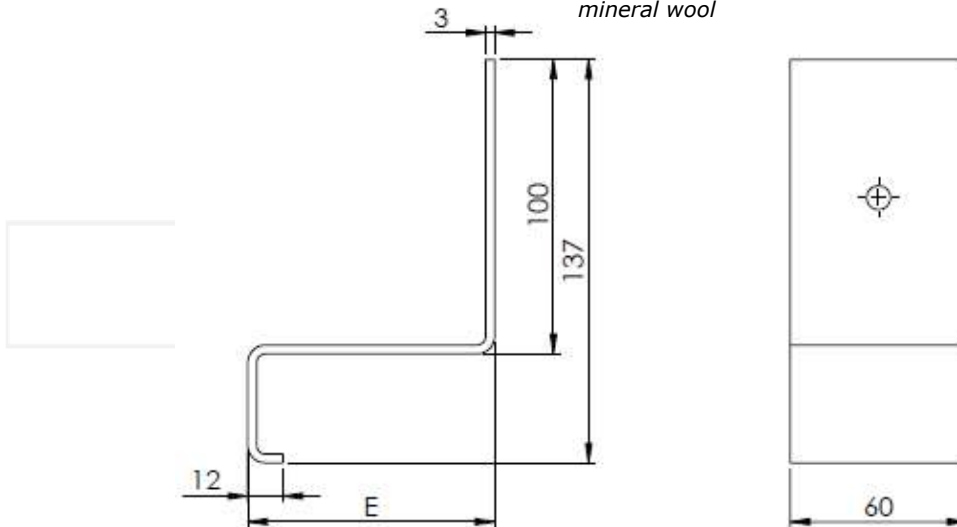

Figure 9. Proposed dimensions of mounting brackets for installation in a ceiling

	Actuator under ceiling	Actuator above ceiling
E [mm]	=Thickness of ceiling - 28	=96

For ceiling with thickness greater than 150 [mm]: connect the damper to the duct before the damper isolation with cement mortar (the damper frame will be bricked up along with a part of the duct).

### 7.3. INSTALLATION TECHNOLOGY - DUCT

- a. Make an opening in the PROMAT duct with the dimensions allowing for installing connection duct into them. (item 7),
- b. Connection duct which have been connect with a damper, connect with the duct with using screws and PROMAT L500 AND PROMATECT-H, and insulate according to Fig. 7.

The damper must be insulated at least to the minimum depth marked with cutouts on the housing.

- c. Suspend the housing taking into account its weight and ceiling load-bearing capacity
- d. Duct with a minimal length of C connect to the damper with a duct manufacturer's standard.
- e. Entire construction: duct, fasteners and insulation made in accordance with the National Technical Assessment No. ITB-KOT-2021/1823 and PROMAT guidelines

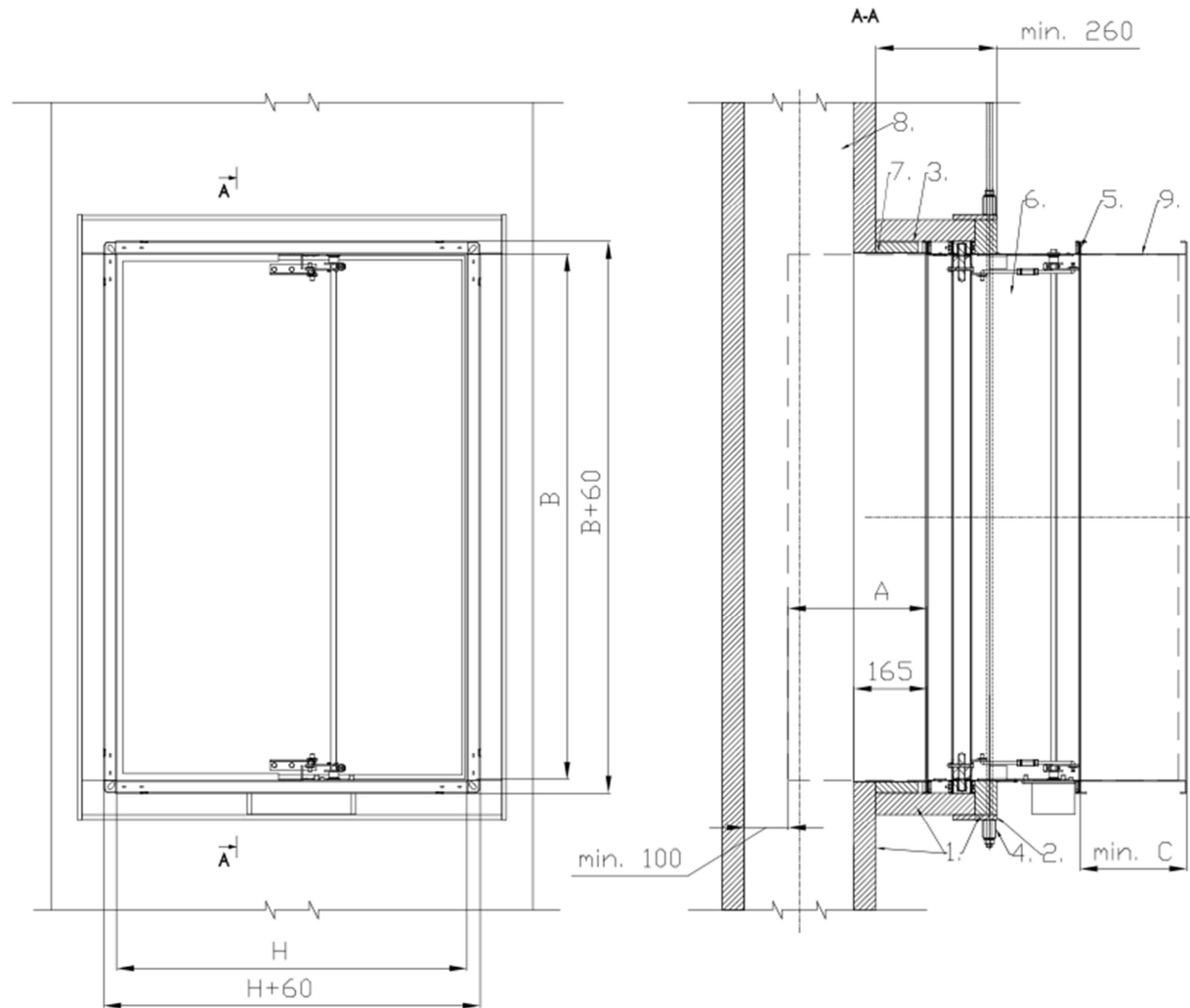

Figure 10. Installation method of dampers on the tee

1. Promatect L-500 board with thickness of 50mm,
2. Insulation of PROMATECT-H board with minimal thickness of 10mm,
3. Insulation of PROMATECT-H board with thickness of 25mm,
4. The support rail must take into account the magnitude of the load
5. Connection in accordance with the standard of the supplier of the ventilation duct, taking into account the weight of the damper,
6. KWP-P-E damper,
7. Connection stub DX51D-Z275 thickness of 1,5mm with dimensions B+5, H+5 [mm] and of length L (in the example 165 [mm]),
8. Length of connection stub should be select in way that distance between bottom of duct and open baffle totals minimal 100 [mm],
9. Multi-zone cable of the class EIS120,
10. Multi-zone / single-zone / ventilation duct or, if the damper completes the installation, a connector with a steel mesh 19x19x1,4mm.

C- length of connector with a steel mesh,  
 when  $H/2-270 < 100\text{mm}$  then  $C \geq 100\text{mm}$ ,  
 when  $H/2-270 > 100\text{mm}$  then  $C \geq H/2-270+50$

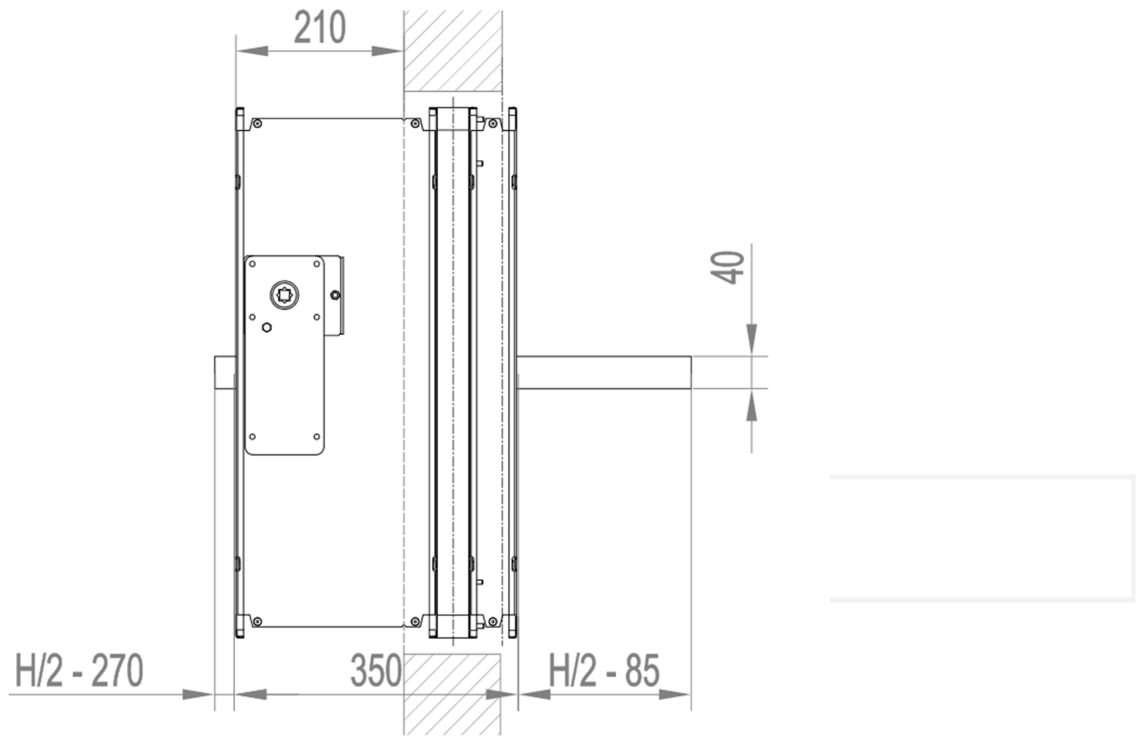

Figure 11. Dimensions of the building partition depending on the high of a damper

## 8. INSTALLATION TECHNOLOGY FOR FIRE DAMPERS IN BATTERIES

The assembly of fire dampers in batteries is possible only after previous delivery of the information (at the stage of ordering) about which fire dampers and in which arrangement (horizontal or vertical) would be installed in a wall, in order to prepare suitable opening for self-tapping screws in the fire damper body.

There are two possibilities of realizing the order of fire damper batteries: basic and complete. First one covers the set of fire dampers, assembly strips and complete set of self-tapping screws. The purchase of other materials needed such as: intumescent gasket (PROMASEAL-PL 20x1,8 mm), mineral wool for thermal insulation (with minimum density of 60 kg/m<sup>3</sup>) and aluminum tape remains with the Customer. The second variant provides for supply by the Manufacturer of complete set of fire dampers and all the elements needed for installation.

The fire dampers are assembled into batteries with use of assembly strips with length of 1200 [mm]. In case when total dimension of their battery is smaller than multiple of the length of the assembling strip, the last one should be cut with angle grinder on the construction site to match the dimension of the battery (basic variant) or cut in manufacturing facility by Manufacturer (complete variant)

Fire dampers should be marked with letters: A, B, C, D.

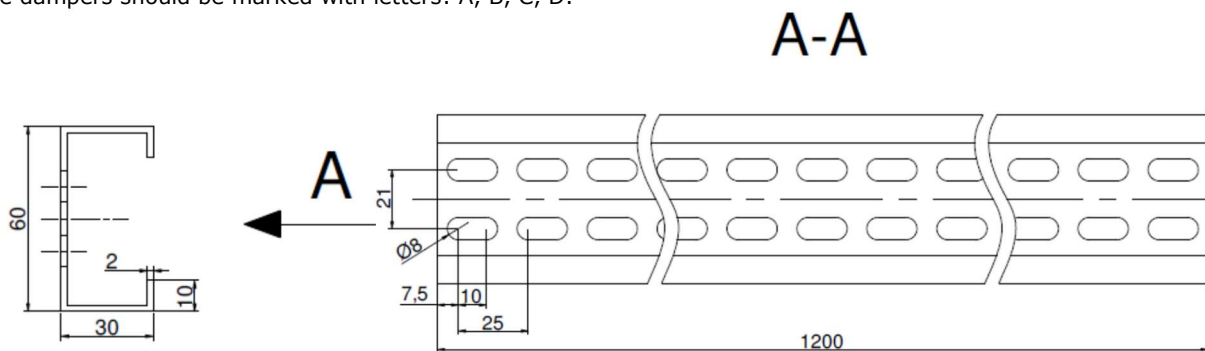

Figure 12. Connection strip

SMAY offers four basic types of damper battery systems.

**Arrangement 1** – vertical battery consisting of two fire dampers KWP

- a. Fix the PROMASEAL-PL gasket with a cross-section of 20×1.8 mm on insulating spacer of one of adjoining fire dampers (position (1) in the Figure 13).
- b. Put non-combustible mineral wool into recess in upper surface of the fire damper. The thickness of mineral wool should be twice as the thickness of the recess in upper surface of the fire damper in order to fill the whole free space between the fire dampers as shown in (w1).

**NOTE:** The alternative way of wool mounting is to use two layers of wool with thickness of 30 mm. In this case, apply the fire resistant PROMASTOP-CC with width of 50 mm. The mass is placed between the strips of wool and between wool and damper housings.

- c. Place the fire damper A on the fire damper B and assemble them together on the front and back with use of perforated assembly strips (2) and self-tapping screws M6x10 (3), which should be tightened into the openings in fire damper body. In order to carry out the correct assembly, 4 self-tapping screws should be used per each assembly strip with length of 1200 [mm].

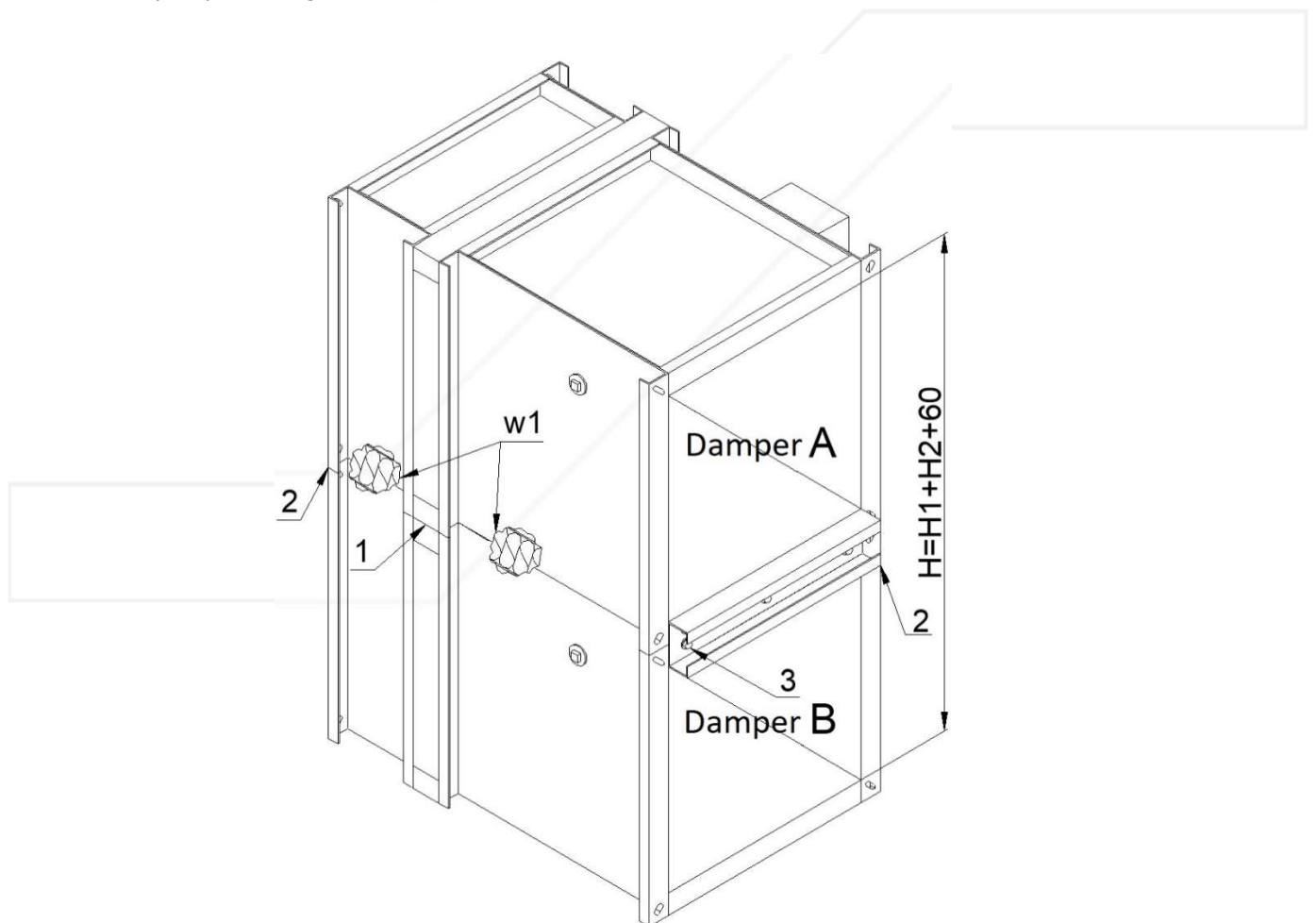

Figure 13. Arrangement 1 - vertical battery consisting of two fire dampers KWP



**Arrangement 2** - vertical battery consisting of three fire dampers KWP

- a. Fix the PROMASEAL-PL gasket with a cross-section of 20×1.8 mm on insulating spacer of one of adjoining fire dampers (position (1) in the Figure 14).
- b. Put non-combustible mineral wool into recess in upper surface of the fire damper. The thickness of mineral wool should be twice as the thickness of the recess in upper surface of the fire damper in order to fill the whole free space between the fire dampers as shown in (w1).

**NOTE:** The alternative way of wool mounting is to use two layers of wool with thickness of 30 mm. In this case, apply the fire resistant PROMASTOP-CC with width of 50 mm. The mass is placed between the strips of wool and between wool and damper housings.

- c. Place the fire damper B on the fire damper C and assemble them together on the front and back with use of perforated assembly strips (2) and self-tapping screws M6×10 (3), which should be tightened into the openings in fire damper body. In order to carry out the correct assembly, 4 self-tapping screws should be used per each assembly strip with length of 1200 [mm].
- d. Repeat accordingly paragraphs 2 and 3 to assemble fire damper A on fire damper B.

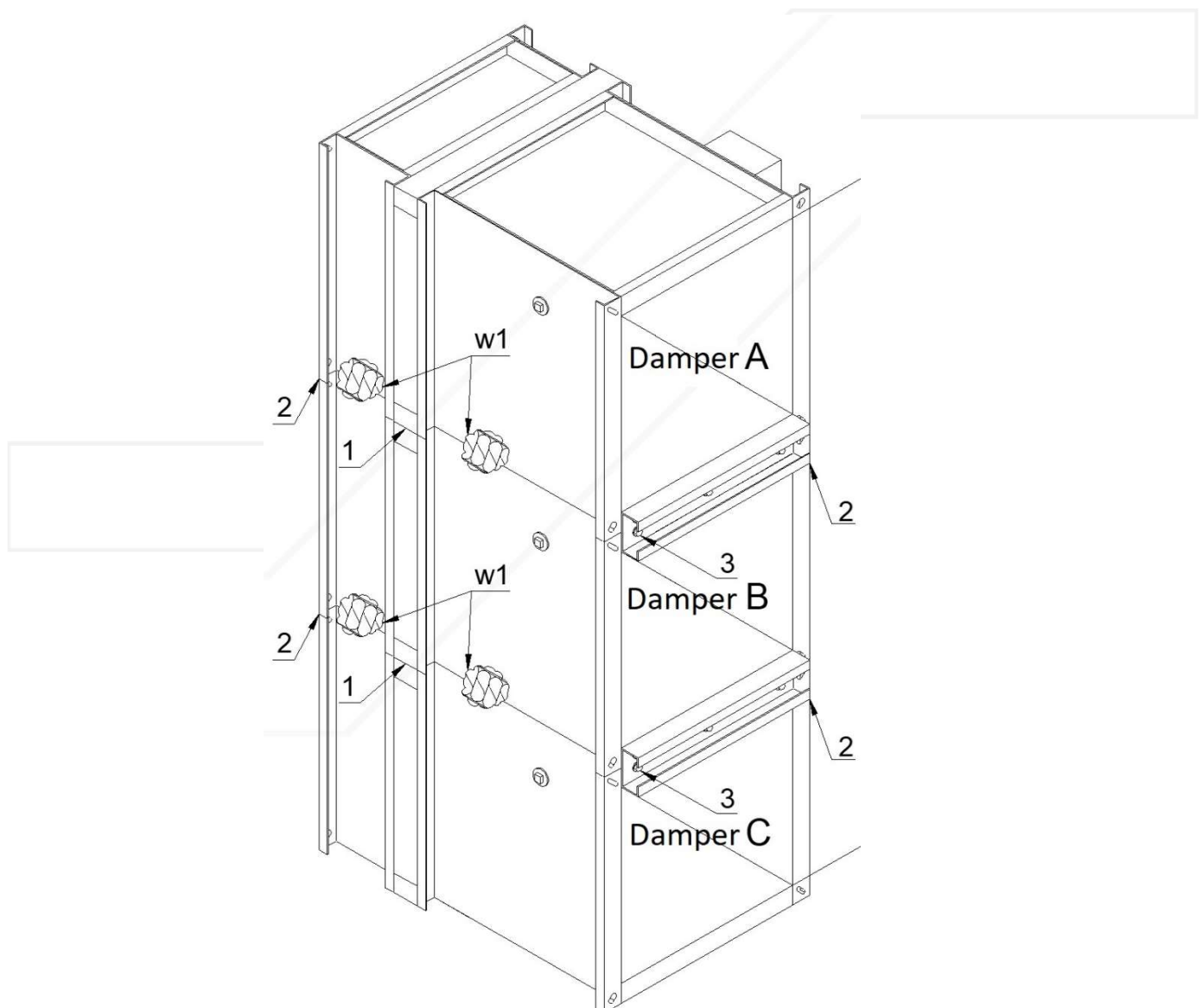

Figure 14. Arrangement 2 - vertical battery consisting of three fire dampers KWP

**Arrangement 3** - horizontal battery consisting of two fire dampers KWP

- a. Fix the PROMASEAL-PL gasket with a cross-section of 20×1.8 mm on insulating spacer of one of adjoining fire dampers (position (1) in the Figure 15).
- b. Set together the sides of fire damper A and the fire damper B (where the gasket was fixed) and assemble them together on the front and back with use of perforated assembly strips (2) and self-tapping screws M6×10 (3), which should be tightened into the openings in fire damper body. In order to carry out the correct assembly, 4 self-tapping screws should be used per each assembly strip with length of 1200 [mm].
- c. Fill the whole free space between the joint of fire dampers with non-combustible mineral wool, as shown in (w1).

**NOTE:** The alternative way of wool mounting is to use two layers of wool with thickness of 30 mm. In this case, apply the fire resistant PROMASTOP-CC with width of 50 mm. The mass is placed between the strips of wool and between wool and damper housings.

- d. The place of sealing the top of the fire damper with mineral wool should be sealed with aluminum tape (4).

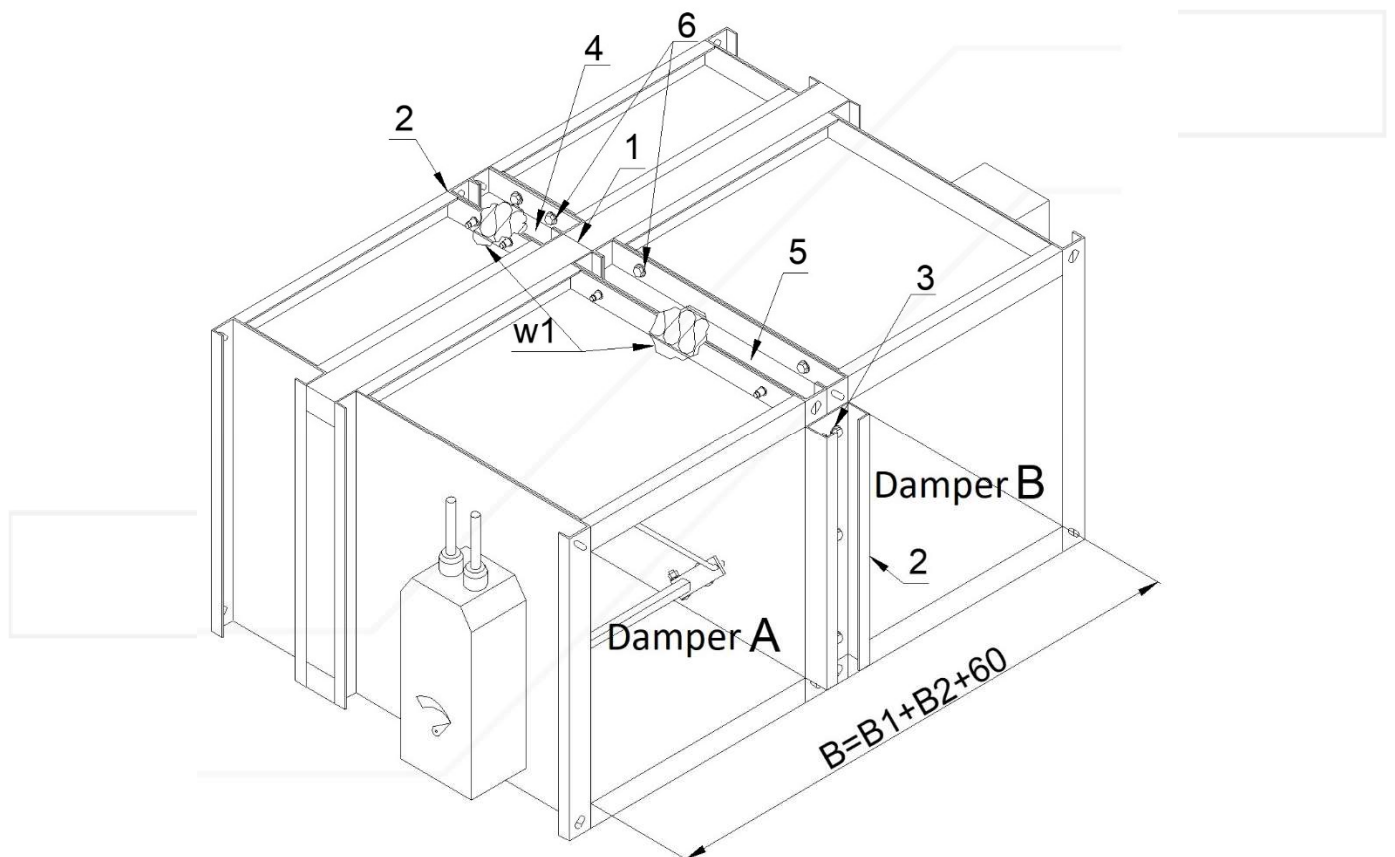

Figure 15. Arrangement 3 – horizontal battery consisting of two fire dampers KWP

**Arrangement 4** – battery consisting of four fire dampers KWP

The assembly of battery consisting of four fire dampers KWP is divided into two steps:

- Step 1 – assembly of fire damper A and fire damper B and assembly of fire damper C and fire damper D.
- Step 2 – assembly of the set of fire dampers A, B and the set of fire dampers C, D.

**STEP 1:**

- a. Fix the gasket on insulating spacer of one of adjoining fire dampers (position (1) in the Figure 16).
- b. Set together the sides of fire damper A and the fire damper B (where the gasket was fixed) and assemble them together on the front and back with use of perforated assembly strips (2) and self-tapping screws M6x10 (3), which should be tightened into the openings in fire damper body. In order to carry out the correct assembly, 4 self-tapping screws should be used per each assembly strip with length of 1200 [mm].
- c. Repeat paragraph 2 to assemble fire damper **C** on the fire damper **D**.

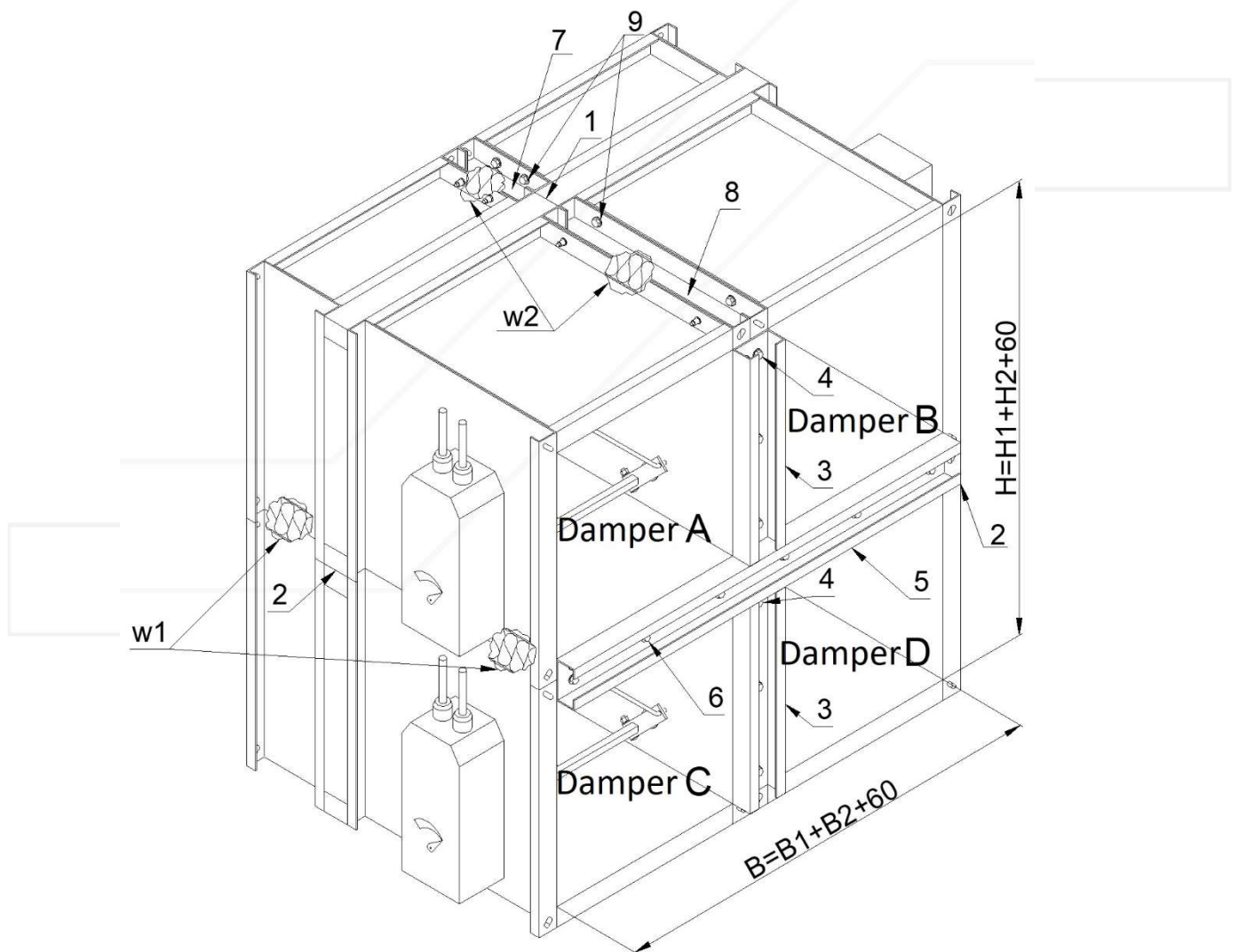

Figure 16. Battery made of four dampers KWP-P

**STEP 2:**

- a. Fix the PROMASEAL-PL gasket with a cross-section of 20×1.8 mm on insulating spacer of one of adjoining fire dampers (position (2) in the Figure 16).
- b. Put non-combustible mineral wool into recess in upper surface of the fire damper C and fire damper D. The thickness of mineral wool should be twice as the thickness of the recess in upper surface of the fire dampers in order to fill the whole free space between the fire dampers C and D and the fire dampers A and B, as shown in (w1).

**NOTE:** The alternative way of wool mounting is to use two layers of wool with thickness of 30mm. In this case, apply the fire resistant PROMASTOP-CC with width of 50 mm. The mass is placed between the strips of wool and between wool and damper housings.

- c. Place the set of fire dampers A and B on the set of fire dampers C and D and assemble them together on the front and back with use of perforated assembly strips (5) and self-tapping screws M6x10 (6), which should be tightened into the openings in fire damper body. In order to carry out the correct assembly, 4 self-tapping screws should be used per each assembly strip with length of 1200 [mm].
- d. The empty space between joint of the bodies of fire dampers A, B and fire dampers C, D should be filled with non-combustible mineral wool (as shown in (w2)).

**NOTE:** The alternative way of wool mounting is to use two layers of wool with thickness of 30mm. In this case, apply the fire resistant PROMASTOP-CC with width of 50 mm. The mass is placed between the strips of wool and between wool and damper housings.

- e. The place of sealing the top of the battery with mineral wool should be sealed with aluminum tape (7).

Installation of KWP fire dampers batteries in rigid wall compartment (Figure 13 to 16)

- a. Make an opening in the wall with dimensions depending on the battery size and its arrangement:
  - For vertical battery consisting of two KWP fire dampers:  $(B1+120) \times (H1+H2+180)$  (Figure 15),
  - For vertical battery consisting of three KWP fire dampers:  $(B1+120) \times (H1+H2+H3+240)$  (Figure 16),
  - For horizontal battery consisting of two KWP fire dampers:  $(B1+B2+180) \times (H1+120)$  (Figure 17),
  - For battery consisting of four KWP fire:  $(B1+B2+180) \times (H1+H2+180)$  (Figure 18),
- b. Put the battery of fire dampers into the installation opening on depth marked by undercuts on the damper body [dimension 60mm]. From one side fix it with suspension Z1, and from other side, fix it to ventilation duct suspended on suspension Z2 according to the figure).

**NOTE:** Fixing of the ductwork has to cover the weight of the battery of fire dampers. Specifically the bolts, anchors, installation frame of the duct and screws used to join the duct with battery of fire dampers should be taken into account. If there is no possibility of ensuring the safe suspension of the battery of fire dampers during installation, the battery should be supported from the bottom side.

- c. After setting the fire damper as described, fill the gap between the fire damper and the wall with cement, cement-lime mortar or concrete or PROMASTOP MG III of production of the PROMAT company.
- d. After 72 hours from the finish of assembly, you can disassemble suspensions.

**REMARKS:**

- a. Install the fire damper in such way, that the damper blades would be in horizontal position.
- b. Fire damper cannot be the support for the constructed wall.
- c. Ductwork cannot be the load for the fire damper, ductwork suspensions have to provide full load capacity.
- d. Ductwork suspensions fixed to the fire damper have to be made in accordance with the ductwork manufacturer instructions.
- e. Selection of mounting rails should be performed in accordance to the guidelines provided by the manufacturer of suspensions, considering weight and arrangement of the battery of fire dampers.
- f. In place of suspensions Z1, Z2 and cement mortar, mounting brackets may be applied! Paying special attention for immobilization of the fire damper).

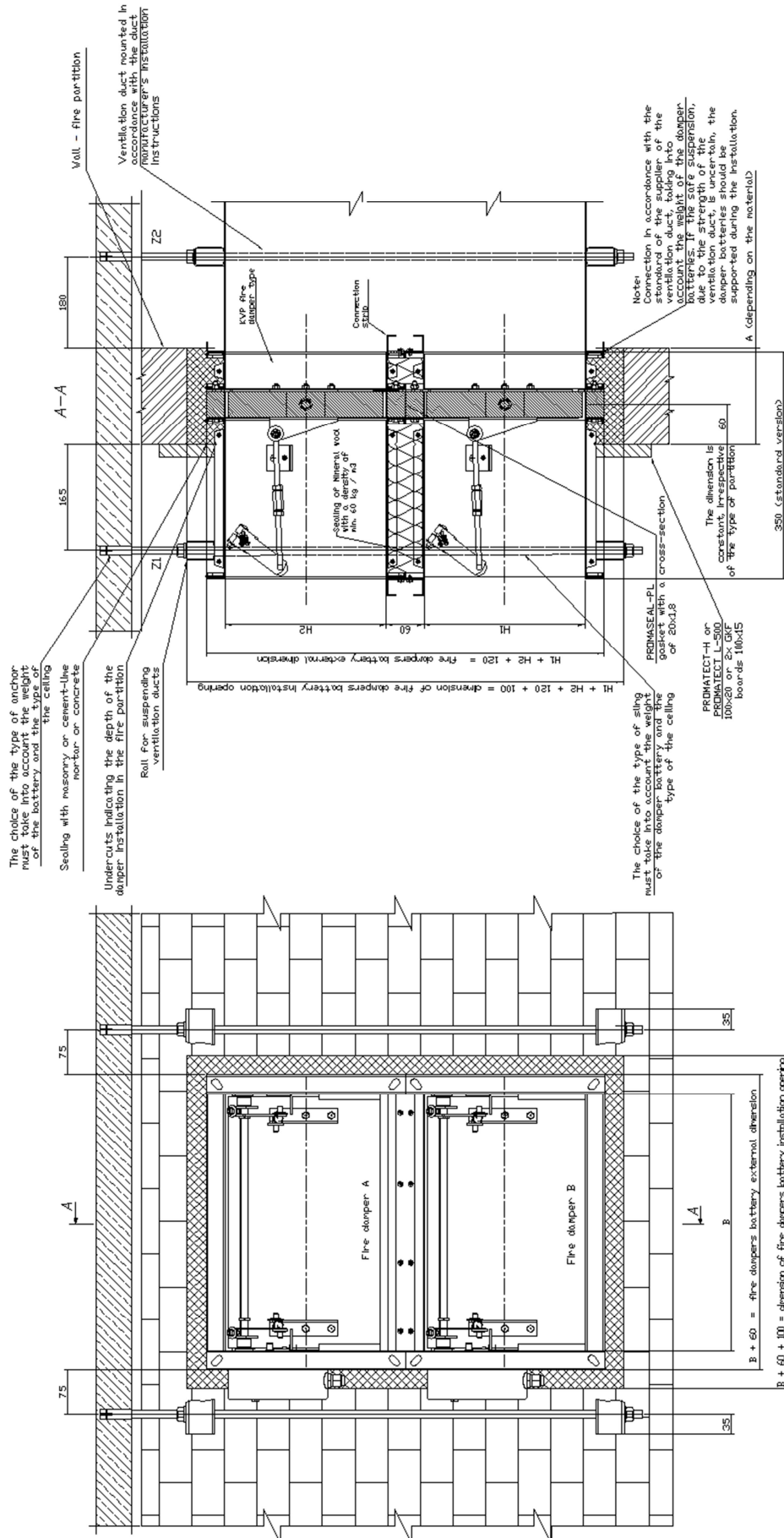

Figure 17. Installation of a battery consisting of two fire dampers KWP in vertical arrangement in wall

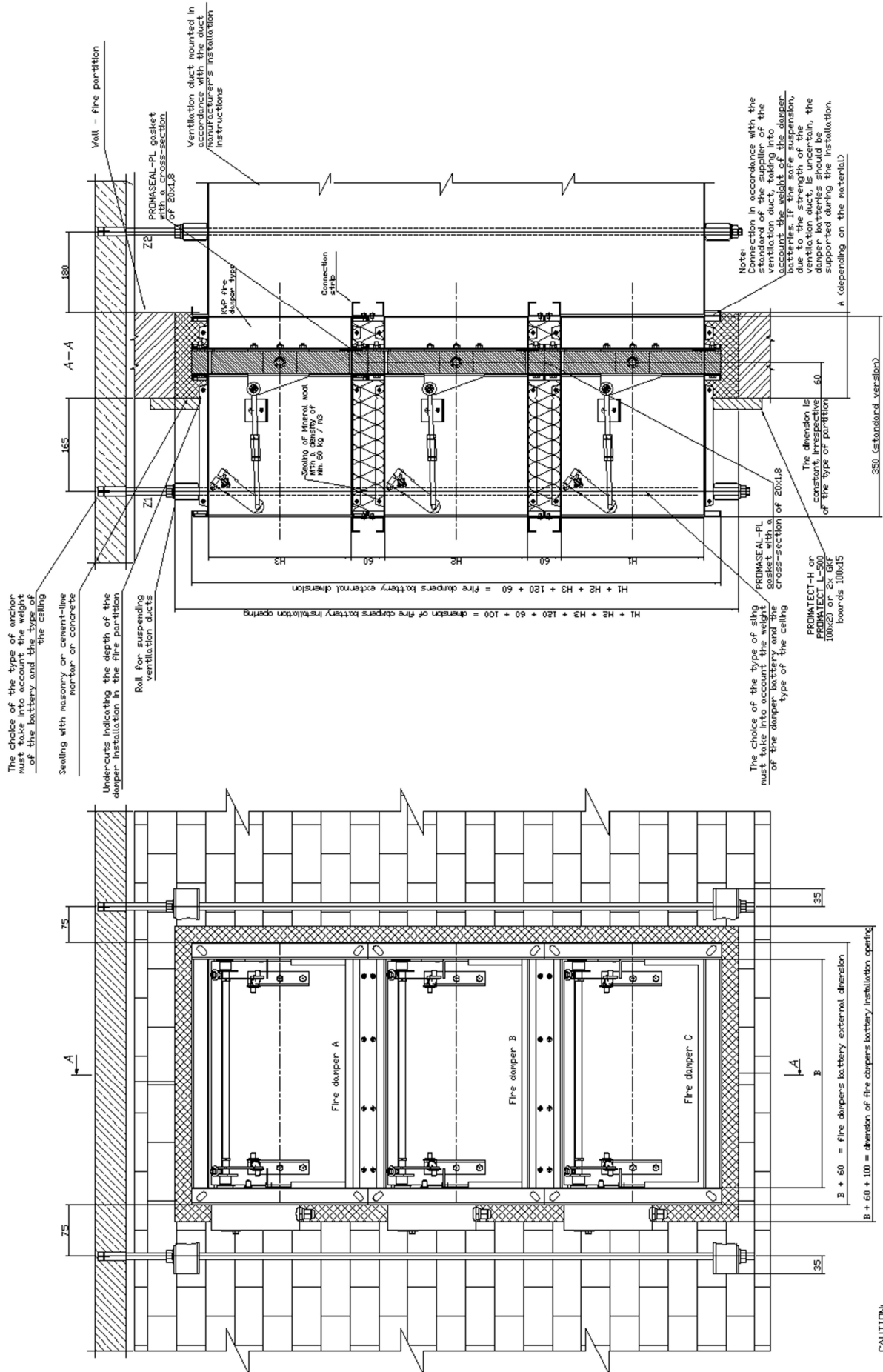

Figure 18. Installation of a battery consisting of three fire dampers KWP in vertical arrangement in wall

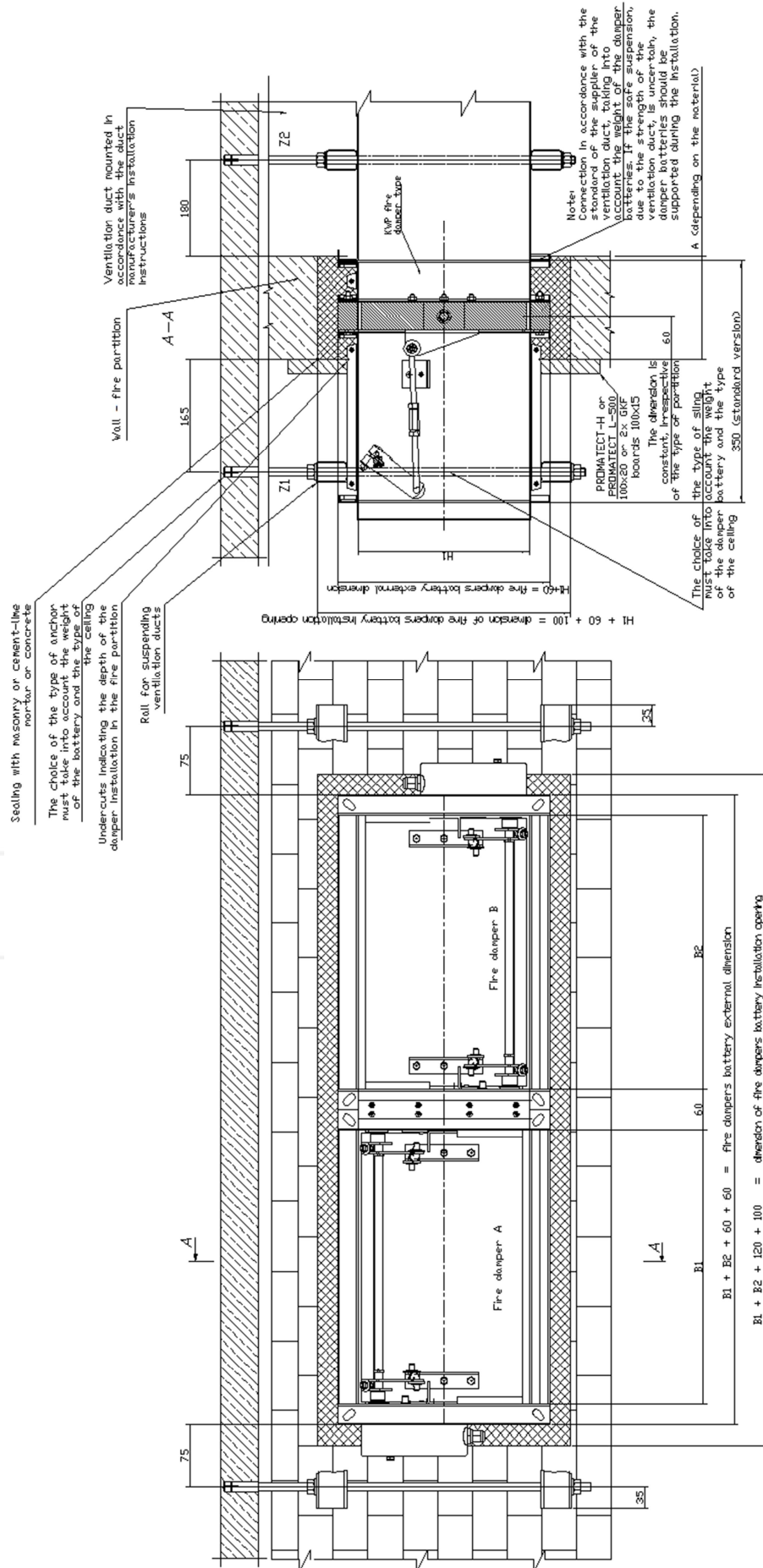

Figure 19. Installation of battery consisting of two fire dampers KWP in horizontal arrangement in wall

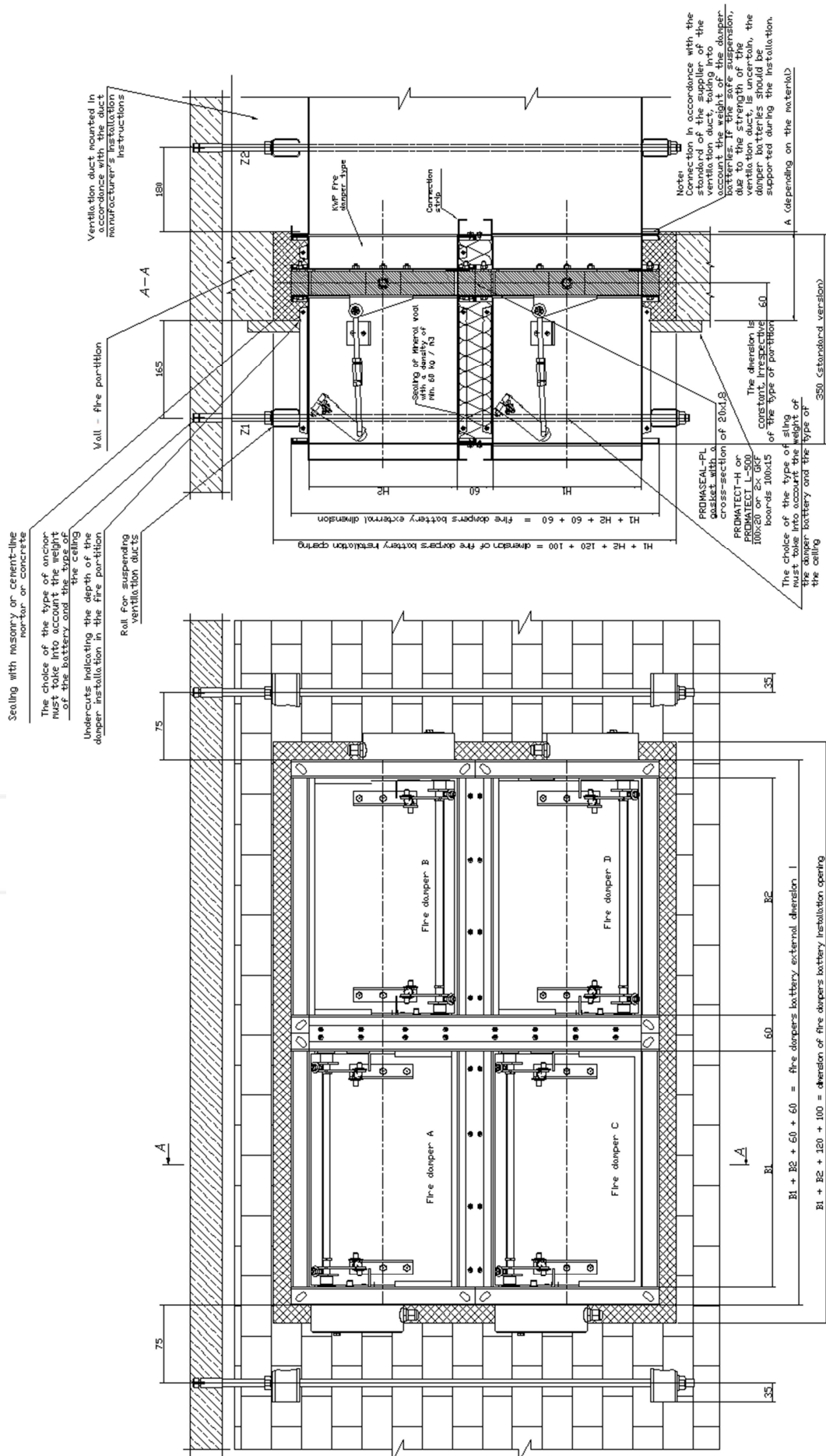

Figure 20. Installation of a battery consisting of four fire dampers KWP in wall



## 9. PRINCIPLES OF MAINTENANCE

Before started any operation and maintenance works it is recommended to read this documentation. This responsibility falls mostly on workers which will operate device/systems during operation and service works. In case of lack of trained personnel (which have specific technical skills) service works should be made by SMAY Service or SMAY Authorized service.

Damage to the KWP-P-E damper resulting from non-compliance with the guidelines included in this documentation, will not be subject to warranty repairs.

Exchange and modification of device components can be done, just by SMAY Service or SMAY Authorized service (does not apply to exchange fusible alloy).

Factory sealed elements, should have undamaged, original seals, installed by SMAY Service or SMAY Authorized service.

After installation of the KWP-P-E fire damper, when running the system, it is recommended to carry out regular checks and record them as shown in table below. It is recommended to repeat checks at intervals or at least once every 6 months.

Table 4. Recommended checks

Fire damper type	
Control date	
Check actuator wiring condition, if doesn` t damaged	
Check limit switch wiring condition, if doesn` t damaged	
Check cleanliness in fire damper, clean if necessary	
Check baffle and seal condition, if necessary report a problem	
Confirm correct operation of safe shutdown of the fire damper, if necessary report a problem	
Confirm correct operation of the fire damper when OPEN and CLOSE, using the control system and physical observation	
Confirm correct operation of limit switches in OPEN and CLOSED positions, if necessary report a problem	
Confirm that the fire damper meets its function as a part of the control system	
Confirm that the fire damper remains its working position	
<p><b>ATTENTION:</b> Fire dampers are usually part of ventilation system. In this case, the entire system should be checked according to the operating and maintenance requirements.</p>	

In order to check the proper functioning of fire damper, in particular:

- a. Check the fire damper without disconnecting the supply voltage from the actuator.
- b. The opening and closing test should be carried out by positioning the baffle from control system („open“ and „closed“ position read on the position indicator located on the actuator).
- c. Take off inspection hatch, make a visual inspection of the interior of fire damper, determine the condition of the baffle and seal, whether there are no damage or dirt that could block the fire baffle during closing. After an inspection put the inspection hatch back.
- d. Put the inspection hatch back. Leave the fire damper in the right work position.
- e. Make a control protocol.

Fire damper can be cleaned with a dry or damp cloth. Dirt and other pollution can be cleaned with generally available cleaners. Do not use aggressive, caustic cleaners and sharp tools.

Table 5.Diagnostic card

Diagnostic card			
No.	Symptoms of malfunction	Causes of malfunction	How to remove malfunction
1	No signaling opening/closing fire damper	1. Failure to fully open the baffle (wrong connected ventilation duct) 2. Improperly connected wires of limit switch 3. Damaged actuator	1. Removing the cause of blocking baffle 2. Correct wiring 3 . Replacing the actuator with a new one (after consulting with fire damper`s manufacturer)
2	No actuator response after connecting power	1 .Damaged actuator 2. Damaged temperature sensor 3. Locked baffle	1. Replacing the actuator with a new one (after consulting with fire damper`s manufacturer) 2. Replacing the temperature sensor to a new one 3 .Removing the cause of blocking baffle
3	No possibility of opening the fire damper with actuator by key	1 .Broken mechanism in the actuator (too rapid rotation) 2.Locked baffle	1. Replacing the actuator with a new one (after consulting with fire damper`s manufacturer) 2. Removing the cause of blocking baffle

## 10. TERMS OF WARRANTY

- a. The manufacturer provides guarantee for the delivered product for a period of 24 months from the date of sale or another period agreed in the contract. There is a possibility of extending the guarantee, provided that a separate Maintenance and Service Agreement is signed between the manufacturer and the owner/manager of the facility.
- b. The basis for complaint handling is to file a complaint within the warranty period, within 7 days of the defect being discovered. Make the product available in the state in which it appeared to be defective, together with a detailed description of the technical problem and documents confirming the performance of any inspection provided by the manufacturer and periodic maintenance.
- c. The manufacturer undertakes to remove the defect within 2 working days of receiving the notification. The manufacturer undertakes to remove the defect within 21 working days from the date of receipt of the application together with the complete set of documents, and in the case of necessity to bring in hard-to-reach materials or parts, the repair will be carried out within the shortest technically reasonable time.
- d. The warranty period is extended by the duration of the repair.
- e. The warranty is valid in the cases described in the OWG.
- f. OWG & OWS documents are available on the website [www.smay.pl](http://www.smay.pl)
- g. Above terms of warranty apply only in Poland.