



CARATTERISTICHE:

Diffusore a pavimento con effetto elicoidale.

COSTRUZIONE:

Alluminio pressofuso e sbavato.
Cestello raccogli-polvere e elicoide di regolazione in acciaio zincato.

IMPIEGO:

Su pavimento galleggiante, in mandata.

FISSAGGIO:

Mediante piastra di fissaggio e viti per pavimenti spessi fino a 50 mm.

CHARACTERISTICS:

Floor twist diffuser.

CONSTRUCTION:

Die-cast and deburred aluminium.
Dirt trap and adjustable swirl element are made of galvanized steel.

UTILIZATION:

For false floor installation and for air delivery.

FIXING:

by fixing plate and screws for false floors with thickness less than 50 mm.

PREZZI - PRICES

■ STOCK

↻	
mm	€
150	
200	

DISEGNI - DRAWINGS

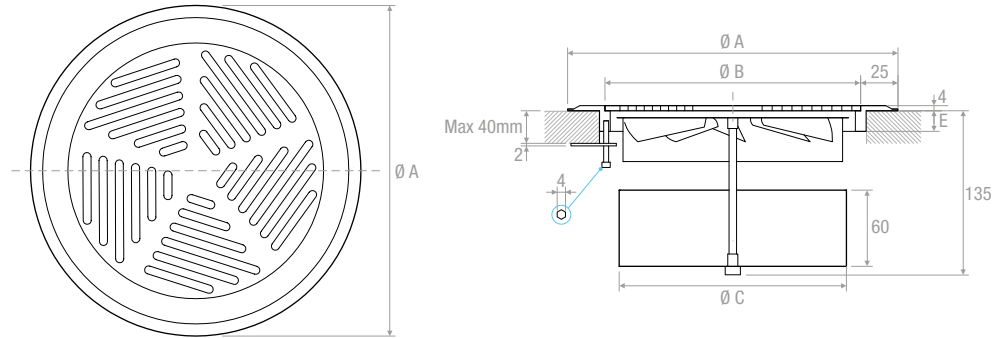

Dimensioni Dimension	Ø A	Ø B	Ø C	E
150	190	140	126	14
200	240	190	176	19

DIAGRAMMA SCELTA RAPIDA - QUICK SELECTION DIAGRAM

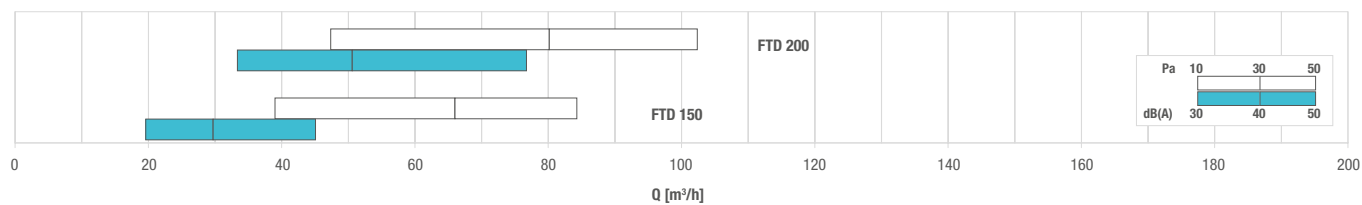

TABELLA DI SELEZIONE - SELECTION TABLE

Modello - Model	A _x [m²]	Q [m³/h]		L _{wa} [dB(A)]		X _(0,25) [m]		Dp _t [Pa]	
		min	max	min	max	min	max	min	max
FTD150	0,00446	40	80	41	58	0,47	0,72	10	50
FTD200	0,01600	50	100	34	50	0,38	0,55	10	50