

DUT

**CARATTERISTICHE:**

Diffusori a ugello a lancio profondo orientabili con angolo massimo di 30° nella versione base DUT e nella versione con serranda DUT-S.

COSTRUZIONE:

Alluminio satinato naturale con primer trasparente.

IMPIEGO:

A soffitto e a parete in mandata.
Altezza di installazione:
2,4-11,5 m.

FISSAGGIO:

Mediante viti frontali sul collare del diffusore al canale o al raccordo per canale circolare.

ACCESSORI:

- RF: Raccordo per tubo flessibile.
- RC: Raccordo per canale circolare.
- CV: copri vite.

CHARACTERISTICS:

Jet diffusers for long throw with orientable nozzle for a maximum angle of 30°.

Normal version DUT and version with damper DUT-S.

CONSTRUCTION:

Natural satinized aluminium with transparent primer.

UTILIZATION:

For ceiling or wall installation for air supply.

Installation height:
2,4-11,5 m.

FIXING:

Fixing by frontal screws mounted on the diffuser ring to the duct or to the connector on circular duct.

ACCESSORIES:

- RF: Flexible duct connection.
- RC: Circular duct connection.
- CV: Covers screws.

PREZZI - PRICES

Modello - Model	DUT	DUT-S	RF	RC	CV
	€	€	€	€	€
80					
110					
150					
200					
230					
250					
300					

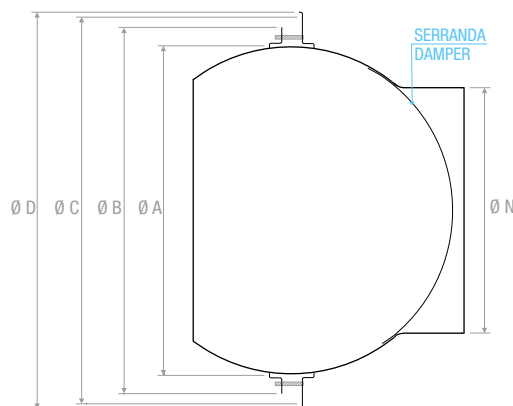
DIMENSIONI - DIMENSION

ØN	ØA	ØB	ØC	ØD
80	160	203	220	254
110	200	246	266	285
150	300	350	368	387
200	400	448	472	485
230	400	448	472	485
250	400	448	472	485
300	400	448	472	485

TABELLA DI SELEZIONE - SELECTION TABLE

Modello Model	A _x [m ²]	Q [m ³ /h]		L _{WA} [dB(A)]		X _(0,25) - Y _(0,25) [m]		Dp _t [Pa]	
		min	max	min	max	min	max	min	max
80	0,0050	60	230	27	54	7,8	20,4	10	70
110	0,0095	120	400	29	55	10,5	26,3	10	70
150	0,0177	240	680	31	58	13,1	28,3	10	70
200	0,0314	400	1200	33	61	14,6	32,4	10	70
230	0,0415	570	1580	36	62	15,9	35,7	10	70
250	0,0491	690	1850	37	64	17,5	38,8	10	70
300	0,0707	900	2650	39	67	18,2	42,9	10	70

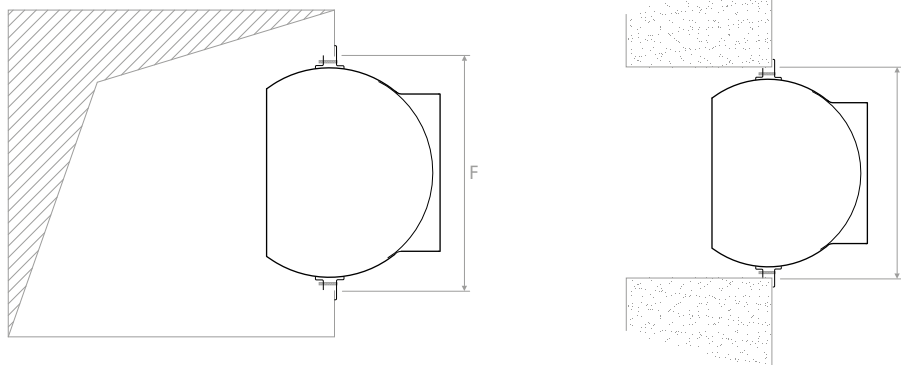
MONTAGGIO SU CANALE E SU PARETE - MOUNTING ON DUCT AND AT WALL

UGELLO - NOZZLE F						
DUT 80	DUT 110	DUT 150	DUT 200	DUT 230	DUT 250	DUT 300
207	250	354	452	452	452	452

Dimensioni foto su canale e su parete - Hole size on duct and at wall

MONTAGGIO SU CANALE E SU PARETE - MOUNTING ON DUCT AND WALL

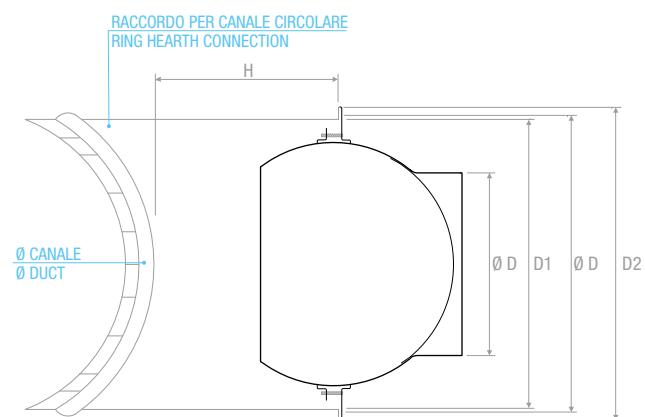

MOD.	N. FORI SU 360°	D	d	D1	D2	H	Ø CANALE Ø DUCT
DUT 80	3F Ø5	220	80	210	230	200	315-630
DUT 110	3F Ø5	266	110	251	282	200	250-800
DUT 150	6F Ø5	368	150	358	378	300	500-800
DUT 200	6F Ø5	472	200	460	480	350	500-1000
DUT 230	6F Ø5	472	230	460	480	350	500-1000
DUT 250	6F Ø5	472	250	460	480	350	500-1000
DUT 300	6F Ø5	472	300	460	480	350	500-1000

MONTAGGIO CON TUBO FLESSIBILE - MOUNTING WITH FLEXIBLE DUCT

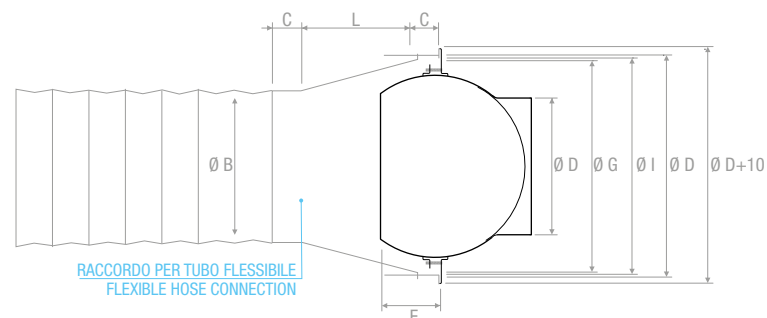

MOD.	D	d	F	B	G	I	L	C
DUT 80	220	80	57	158	203	210	100	60
DUT 110	266	110	100	195	246	251	100	60
DUT 150	368	150	60	313	350	358	170	60
DUT 200	472	200	141	398	448	462	170	60
DUT 230	472	230	141	398	448	462	170	60
DUT 250	472	250	141	398	448	462	170	60
DUT 300	472	300	141	398	448	462	170	60

MONTAGGIO IN BATTERIA - MOUNTING ON PANEL

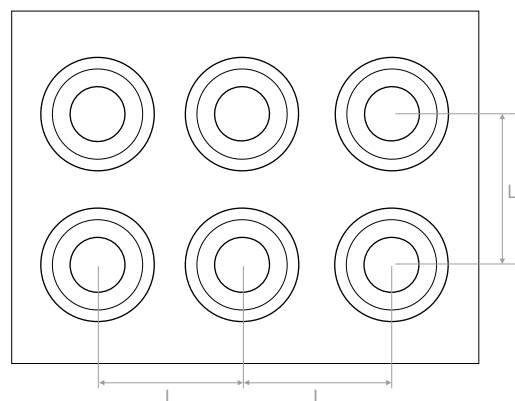

DATI DIMENSIONALI - DATA SHEET

Ugello - Nozzle	L min. (mm)
DUT 80	300
DUT 110	350
DUT 150	430
DUT 200	430
DUT 230	550
DUT 250	550
DUT 300	550

