

**Range extension:
New models up to 15.000 m³/h**



Constructive design of models RHE
VD: Vertical discharge

High efficient heat recovery units up to 88% with rotary wheel, plug-fans with backward curved blades and EC external-rotor motor. Pre-configured control system for easy start-up. The casing is made of 50 mm, self-supporting double skinned panels (mineral wool, 40 kg/m³, thermal conductivity 0.037 W/ mK). The outer skin is made from coated steel (RAL7024) with a high resistance against corrosion (class: RC3) and UV light (class: RUV3) according to EN 10169 and the inner skin is made from galvanised steel. Support feet are made from 3 mm, RAL9011 coated, 100 mm height (except RHE 6000 to 10000 models, which are base-mounted), with possibility to fit anti-vibration mounts or leveling feet (as accessories). Easy access to all components via large hinged front doors. Circular inlet and discharge connection flanges with EPDM rubber seal strip, VELODUCT® tightness class D up to size 3500 HD, rectangular connections for the sizes 4500 VD, 6000, 8000, 10000 and 15000.

Fan / Motor

Plug-fan with backward curved blades, external rotor EC motor with maintenance free ball bearings and permanent lubrication, with integrated electronic protection (locked-rotor, phase failure, under-voltage, over-temperature, short-circuit). Protection IP54, Class B. (RHE-8000/10000/15000 models, Class F)

Application

Public buildings, offices, stores, schools, restaurants.

Range

Versions:

- horizontal discharge HD
- vertical discharge VD
- horizontal discharge for outdoor installation HD OI

Sizes: 700 m³/h, 1300 m³/h, 1900 m³/h, 2500 m³/h, 3.500 m³/h, 4500 m³/h, 6000 m³/h, 8000 m³/h, 10000 m³/h and 15000 m³/h.

Models:

- RHE D: without additional heater
- RHE DI: with built-in electric post-heating
- RHE DC: with built-in hot water coil
- RHE DFR: with 2-row coil built-in reversible hot/chilled water integrated (the cold water version coil only for the models HD)
- RHE DFR4R: with 4-row coil built-in reversible hot/chilled water integrated (for models 6000, 8000, 10000 and 15000).
- RHE DC/DF: with 2 independent integrated coils (chilled water and hot water).
- RHE DX: direct expansion integrated coil (only for horizontal discharge, HD versions, except 15000 model).

Control (Pul&Play):

VAV - variable air volume

Fan speed can be adjusted with a 0 - 10V signal from the remote touchscreen panel (included) or an external CO₂, temperature or humidity sensor (accessories).

CAV - constant air volume

Manual pre-setting of 2 working points. The fans are controlled separately.

COP - constant pressure

Constant pressure measured by an external sensor (accessory).



Constructive design of models RHE HDR:
Horizontal discharge and access from the right side.

RHE - standard range

RHE-SO - range with sorption exchanger wheel



Heat Recovery

REFERENCE

R	H	E	-	2	5	0	0	-	HDR	-	DC	-	OI	-	SO
1				2					3		4		5		6

- 1 - Serie.
- 2 - Size.
- 3 - **HDR:** Horizontal discharge and access from the right side.
HDL: Horizontal discharge and access from the left side.
VDR: Top connections. Inner air side on the right.
VDL: Top connections. Inner air side on the left.
- 4 - **D:** Standard range.
DI: Range with built-in electric heater.
DC: Range with built-in hot water coil.
DFR: Range with 2-row coil build in reversible water coil.
DFR4R: Range with built-in reversible 4-row water coil
DC/DF: With 2 separated integrated coils(chilled and hot water).
DX: Range with integrated direct expansion coil.
- 5 - **Ø:** Without roof.
OI: Outdoor installation.
- 6 - **Ø:** Aluminum rotary exchanger (Std.).
SO: Sorption wheel.

VERSIONS ACCORDING TO ACCESS SIDE

The access side is defined by the direction of supply air.

HDR models, with access from the right side.

HDL models, with access from the left side.

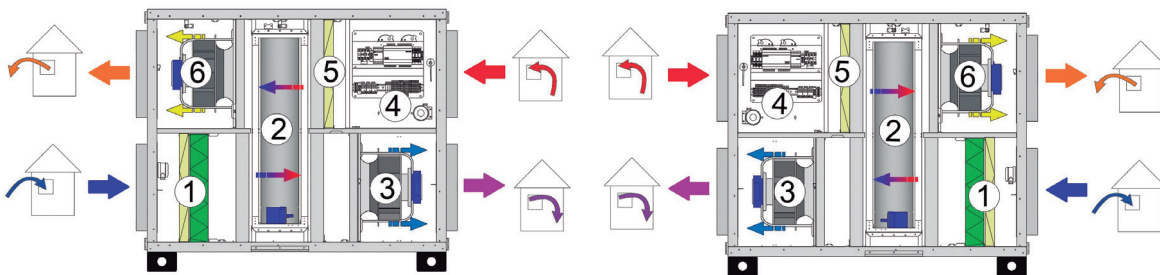

Only models with horizontal discharge are available with access from different sides.

Vertical configuration

VDR models: Inner side connections on the right.

VDL models: Inner side connections on the left.

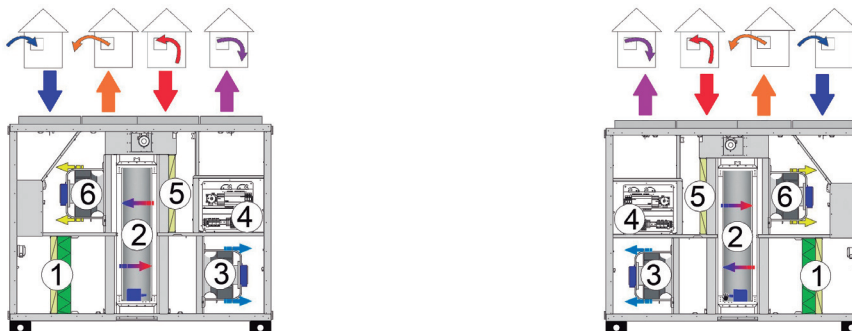

Component Identification

- 1. Supply filters.
- 2. Heat exchanger.
- 3. Supply fan.
- 4. Electronic control.
- 5. Extraction filter.
- 6. Extraction fan.

COMPONENTS ACCORDING TO VERSIONS

Electric heater coil (DI)

- Heater elements are made of stainless Steel AISI 430.
- Built-in overheating protection thermostat with automatic reset at 70°C and manual reset at 120°C.

Hot water coil (DC)

- 2 row hot water coil made of copper pipes and aluminium fins.
- Motorized (24V) 3 way valve for proportional (0-10V) control (accessory).
- Anti-frost protection by clamp-on temperature sensor to the return flow pipe.

Hot / Chilled water, reversible coil (DFR / DFR4R) (Only for HD version available)

- 2 or 4 row hot water coil made of copper pipes and aluminium fins.
- Motorized (24V) 3 way valve for proportional (0-10V) control (accessory).
- Anti-frost protection by clamp-on temperature sensor to the return flow pipe.
- With welded stainless steel condensate dip tray and droplet separator.
- Condensate drain (diameter ½") located under the unit. It has to be connected to a siphon.
- Built-in changeover thermostat (THCO) which controls a mixing valve depending on the outdoor temperature.

Hot water coil+ chilled water coil (DC/DF) (only for 6000, 8000, 10000 and 15000 models)

- 2 row coils in hot water and chilled water.
- Anti-frost protection by clamp-on temperature sensor to the return flow pipe.
- Construction:
 - Copper tubes and collectors.
 - Tubes with threaded connection.
 - Aluminium fins.
 - Galvanised steel frame.
- 3-way motorised valves (24V) for proportional control 0-10V (accessory).
 - With condensate tray of stainless steel.

Direct expansion coil (DX) only for HD versions, provided without control (direct expansion coil does not exist for RHE 15000 model)

- 2 or 3 row coils, designed to operate in evaporation mode or in condensation mode.
- Construction:
 - Copper tubes and collectors.
 - Aluminium fins.
 - Galvanised steel frame.
 - With condensate tray of stainless steel.

Filter

- M5 (ePM10 75%) filter on the extract air side to protect the heat exchanger.
- G4 (Grossier 60%) and F7 (ePM1 55%) filters on the outdoor air side.
- The filter clogging is checked by differential pressure sensor measuring and transmitting the pressure drop to the control.

Control system

- Built-in programmable control system (Plug & Play).
- MODBUS RTU (RS485) and BACNET IP communication protocol.
- Remote touchscreen panel (ETD) included.

CONTROL SYSTEM FEATURES AND FUNCTIONS

RHE control system	D	DI	DC	DFR	DC/DF	DX
MAIN COMPONENTS						
Internal electrical box – composition:						
• Main power connection switch / safety circuit breaker	●	●	●	●	●	●
• Controller and terminal strip integrated into the unit, easy access main side	●	●	●	●	●	●
FUNCTIONS						
Air flow control						
• Constant air volume (CAV): 2 different setpoint speed on supply and exhaust air	●	●	●	●	●	●
• Variable air volume (VAV): signal 0-10V coming from an outdoor probe (CO ₂ , temperature, relative humidity, etc.) or a manual percentage across the control panel	●	●	●	●	●	●
• Constant pressure (COP) value measured by an outdoor pressure sensor (SPRD+KTPR = Accessories)	●	●	●	●	●	●
• Time programming (week timer, Holiday periods...)	●	●	●	●	●	●
• Extending running BOOST by external contact demand	●	●	●	●	●	●
• On/Off system by external contact	●	●	●	●	●	●
Temperature control						
Temperature sensor:						
• Outdoor air temperature sensor	●	●	●	●	●	●
• Extract air temperature sensor	●	●	●	●	●	●
• Supply air temperature sensor	●	●	●	●	●	●
• Anti-frost sensor on water coil (DC-DFR)			●	●	●	
• «CHANGE OVER» thermostat installed on water input pipe (DFR)				●		
Free cooling by switching off the heat exchanger rotation (Intermittant rotation of wheel reduces risk of dust clogging)						
	●	●	●	●	●	●
Outdoor air damper actuator control (damper-accessory)						
	●	●	●	●	●	●
Internal electric heater coil control:						
• Proportional control (PWM)		●			●	
Internal water coil control:						
• Motorized 3 way valve proportional 0-10 V unmounted			⊙	⊙	⊙	
• Airflow regulation via 3-way valve.			●	●	●	
External water coil(s) control:						
• Power control of the external hot or chilled water coil by a proportional signal 0-10V	⊙ (1)	⊙ (1)	⊙ (2)	⊙ (3)		
• Supply air duct sensor TKG3 PT1000	⊙	⊙	⊙	⊙		
• Anti-frost sensor on water coil TGA1 PT1000	⊙	⊙		⊙		
• CHANGE OVER thermostat to be installed on water input pipe	⊙	⊙				
Security and alarm control						
• Filter clogging indication	●	●	●	●	●	●
• Malfunction of connected sensor	●	●	●	●	●	●
• Malfunction of fan	●	●	●	●	●	●
• Result deviates too much from the set point (Airflow, Pressure, T°)	●	●	●	●	●	●
• Fire alarm (contact available)	●	●	●	●	●	●
• Communication failure between controller and display control	●	●	●	●	●	●
• Anti-frost protection for the water coil (force the heating valve to open thereby preventing freeze-up of the heater if water T° lower than 7°C on heating mode - stop the unit if the water T° do not increase)	●	●	●	●	●	
• Alarm management (40 latest alarms)	●	●	●	●	●	●
Communication						
• Remote touch screen panel	●	●	●	●	●	●
• Maintenance display DSP	⊙	⊙	⊙	⊙	⊙	⊙
• MODBUS RTU (RS485) and BACNET IP communication protocol.	●	●	●	●	●	●
• BACNET IP	●	●	●	●	●	●

● Included

⊙ Accessory

(1) hot or chilled water coil, (2) chilled water coil, (3) hot water coil

TECHNICAL CHARACTERISTICS

Hot water coil data DC for units with vertical discharge (VD)

RHE 700 VD - Airflow 700 m³/h											
Outdoor Air (ODA)	Extract Air (ETA)	Supply Air (SUP) before DC coil	Water Temp. (°C)	Heating Power (kW)	Supply Air (SUP) after DC coil		Air Pressure Drop (Pa)	Water flow (l/h)	Water pressure drop (kPa)	Coil connection Ø (")	Recommended 3 way valve
					Temperature (°C)	Relative Humidity (%)					
-10°C - 90% RH	20°C - 50% RH	15°C - 47%RH	45/40	2,99	28	22	27	517	7,5	1/2	3WV DN15 KVS1,6 PROP 24V
			60/40	3,15	28	21		137	4,8	1/2	3WV DN15 KVS1 PROP 24V
			80/60	5,73	39	11		253	5,2	1/2	3WV DN15 KVS1 PROP 24V
			90/70	6,97	44	9		390	5,5	1/2	3WV DN15 KVS1 PROP 24V

RHE 1300 VD - Airflow 1300 m³/h											
Outdoor Air (ODA)	Extract Air (ETA)	Supply Air (SUP) before DC coil	Water Temp. (°C)	Heating Power (kW)	Supply Air (SUP) after DC coil		Air Pressure Drop (Pa)	Water flow (l/h)	Water pressure drop (kPa)	Coil connection Ø (")	Recommended 3 way valve
					Temperature (°C)	Relative Humidity (%)					
-10°C - 90% RH	20°C - 50% RH	12°C - 53%RH	45/40	4,8	23	26	84	846	12	1/2	3WV DN15 KVS1,6 PROP 24V
			60/40	5,14	24	25		224	5,1	1/2	3WV DN15 KVS1,6 PROP 24V
			80/60	8,86	32	26		391	6,2	1/2	3WV DN15 KVS1,6 PROP 24V
			90/70	10,71	36	12		475	6,8	1/2	3WV DN15 KVS1,6 PROP 24V

RHE 1900 VD - Airflow 1900 m³/h											
Outdoor Air (ODA)	Extract Air (ETA)	Supply Air (SUP) before DC coil	Water Temp. (°C)	Heating Power (kW)	Supply Air (SUP) after DC coil		Air Pressure Drop (Pa)	Water flow (l/h)	Water pressure drop (kPa)	Coil connection Ø (")	Recommended 3 way valve
					Temperature (°C)	Relative Humidity (%)					
-10°C - 90% RH	20°C - 50% RH	13°C - 51%RH	45/40	7,85	24	23	67	1358	33,9	1/2	3WV DN15 KVS1,6 PROP 24V
			60/40	8,77	25	21		382	6,9	1/2	3WV DN15 KVS1,6 PROP 24V
			80/60	14,4	34	13		637	10,2	1/2	3WV DN15 KVS1,6 PROP 24V
			90/70	17,3	39	10		767	12,4	1/2	3WV DN15 KVS1,6 PROP 24V

RHE 2500 VD - Airflow 2500 m³/h											
Outdoor Air (ODA)	Extract Air (ETA)	Supply Air (SUP) before DC coil	Water Temp. (°C)	Heating Power (kW)	Supply Air (SUP) after DC coil		Air Pressure Drop (Pa)	Water flow (l/h)	Water pressure drop (kPa)	Coil connection Ø (")	Recommended 3 way valve
					Temperature (°C)	Relative Humidity (%)					
-10°C - 90% RH	20°C - 50% RH	13°C - 51%RH	45/40	10,67	25	23	49	1848	25	3/4	3WV DN20 KVS4 PROP 24V
			60/40	12,05	27	21		525	6,3	3/4	3WV DN15 KVS2,5 PROP 24V
			80/60	20,02	36	12		883	8,9	3/4	3WV DN15 KVS2,5 PROP 24V
			90/70	24	41	9		1065	10,6	3/4	3WV DN15 KVS2,5 PROP 24V

RHE 3500 VD - Airflow 3500 m³/h											
Outdoor Air (ODA)	Extract Air (ETA)	Supply Air (SUP) before DC coil	Water Temp. (°C)	Heating Power (kW)	Supply Air (SUP) after DC coil		Air Pressure Drop (Pa)	Water flow (l/h)	Water pressure drop (kPa)	Coil connection Ø (")	Recommended 3 way valve
					Temperature (°C)	Relative Humidity (%)					
-10°C - 90% RH	20°C - 50% RH	13°C - 51%RH	45/40	15,3	26	23	44	2655	34,3	3/4	3WV DN20 KVS4 PROP 24V
			60/40	17,4	28	20		762	7,1	3/4	3WV DN20 KVS4 PROP 24V
			80/60	28,8	37	12		1272	10,8	3/4	3WV DN20 KVS4 PROP 24V
			90/70	34,5	42	8		1531	13	3/4	3WV DN20 KVS4 PROP 24V

RHE 4500 VD - Airflow 4500 m³/h											
Outdoor Air (ODA)	Extract Air (ETA)	Supply Air (SUP) before DC coil	Water Temp. (°C)	Heating Power (kW)	Supply Air (SUP) after DC coil		Air Pressure Drop (Pa)	Water flow (l/h)	Water pressure drop (kPa)	Coil connection Ø (")	Recommended 3 way valve
					Temperature (°C)	Relative Humidity (%)					
-10°C - 90% RH	20°C - 50% RH	12°C - 53%RH	45/40	18,41	24	24	68	2656	35,5	3/4	3WV DN20 KVS4 PROP 24V
			60/40	21,32	25	22		929	8,3	3/4	3WV DN20 KVS4 PROP 24V
			80/60	34,67	34	13		1529	13,3	3/4	3WV DN20 KVS4 PROP 24V
			90/70	41,3	39	11		1833	16,4	3/4	3WV DN20 KVS4 PROP 24V

HIGH EFFICIENCY HEAT RECOVERY UNITS WITH ROTARY WHEEL

RHE Series



TECHNICAL CHARACTERISTICS

Water coil data for units with horizontal discharge, hot water or reversible hot/chilled water coil DC/DFR

RHE 700 HD - Airflow 700 m³/h											
Outdoor Air (ODA)	Extract Air (ETA)	Supply Air (SUP) before DC coil	Water Temp. (°C)	Heating Power (kW)	Supply Air (SUP) after DC coil		Air Pressure Drop (Pa)	Water flow (l/h)	Water pressure drop (kPa)	Coil connection Ø (")	Recommended 3 way valve
					Temperature (°C)	Relative Humidity (%)					
-10°C - 90% RH	20°C - 50% RH	15°C - 47%RH	45/40	3,48	29	19	14	602	9,7	1/2	3WV DN15 KVS1,6 PROP 24V
			60/40	3,97	31	17		173	5	1/2	3WV DN15 KVS1 PROP 24V
			80/60	6,78	43	9		299	5,8	1/2	3WV DN15 KVS1 PROP 24V
			90/70	8,17	49	7		363	6,3	1/2	3WV DN15 KVS1 PROP 24V
35°C - 40% RH	26°C - 50% RH	28°C - 61% RH	7/12	2,42	21	82	34	417	7,6	1/2	3WV DN15 KVS1 PROP 24V

RHE 1300 HD - Airflow 1300 m³/h											
Outdoor Air (ODA)	Extract Air (ETA)	Supply Air (SUP) before DC coil	Water Temp. (°C)	Heating Power (kW)	Supply Air (SUP) after DC coil		Air Pressure Drop (Pa)	Water flow (l/h)	Water pressure drop (kPa)	Coil connection Ø (")	Recommended 3 way valve
					Temperature (°C)	Relative Humidity (%)					
-10°C - 90% RH	20°C - 50% RH	12°C - 53%RH	45/40	5,81	25	23	44	1006	18,2	1/2	3WV DN15 KVS1,6 PROP 24V
			60/40	6,47	27	21		282	5,8	1/2	3WV DN15 KVS1,6 PROP 24V
			80/60	10,7	36	12		474	7,6	1/2	3WV DN15 KVS1,6 PROP 24V
			90/70	12,8	41	9		571	8,8	1/2	3WV DN15 KVS1,6 PROP 24V
35°C - 40% RH	26°C - 50% RH	28°C - 58% RH	7/12	3,56	22	77	92	612	10,7	1/2	3WV DN15 KVS1,6 PROP 24V

RHE 1900 HD - Airflow 1900 m³/h											
Outdoor Air (ODA)	Extract Air (ETA)	Supply Air (SUP) before DC coil	Water Temp. (°C)	Heating Power (kW)	Supply Air (SUP) after DC coil		Air Pressure Drop (Pa)	Water flow (l/h)	Water pressure drop (kPa)	Coil connection Ø (")	Recommended 3 way valve
					Temperature (°C)	Relative Humidity (%)					
-10°C - 90% RH	20°C - 50% RH	12°C - 51%RH	45/40	8,9	26	21	37	1542	16,7	3/4	3WV DN15 KVS2,5 PROP 24V
			60/40	9,98	27	19		435	5,7	3/4	3WV DN15 KVS2,5 PROP 24V
			80/60	16,4	37	11		724	7,3	3/4	3WV DN15 KVS2,5 PROP 24V
			90/70	19,6	42	8		871	8,3	3/4	3WV DN15 KVS2,5 PROP 24V
35°C - 40% RH	26°C - 50% RH	28°C - 58% RH	7/12	5,47	22	78	79	940	10,2	3/4	3WV DN15 KVS2,5 PROP 24V

RHE 2500 VD - Airflow 2500 m³/h											
Outdoor Air (ODA)	Extract Air (ETA)	Supply Air (SUP) before DC coil	Water Temp. (°C)	Heating Power (kW)	Supply Air (SUP) after DC coil		Air Pressure Drop (Pa)	Water flow (l/h)	Water pressure drop (kPa)	Coil connection Ø (")	Recommended 3 way valve
					Temperature (°C)	Relative Humidity (%)					
-10°C - 90% RH	20°C - 50% RH	13°C - 51%RH	45/40	11,7	27	21	33	2032	37,9	3/4	3WV DN15 KVS2,5 PROP 24V
			60/40	13,5	29	18		591	7,4	3/4	3WV DN15 KVS2,5 PROP 24V
			80/60	22,1	39	10		978	11,3	3/4	3WV DN15 KVS2,5 PROP 24V
			90/70	26,4	44	8		1175	13,7	3/4	3WV DN15 KVS2,5 PROP 24V
35°C - 40% RH	26°C - 50% RH	28°C - 59% RH	7/12	7,6	22	78	72	1307	19,7	3/4	3WV DN15 KVS2,5 PROP 24V

RHE 3500 HD - Airflow 3500 m³/h											
Outdoor Air (ODA)	Extract Air (ETA)	Supply Air (SUP) before DC coil	Water Temp. (°C)	Heating Power (kW)	Supply Air (SUP) after DC coil		Air Pressure Drop (Pa)	Water flow (l/h)	Water pressure drop (kPa)	Coil connection Ø (")	Recommended 3 way valve
					Temperature (°C)	Relative Humidity (%)					
-10°C - 90% RH	20°C - 50% RH	13°C - 51%RH	45/40	16,8	27	21	28	2910	30,6	3/4	3WV DN20 KVS4 PROP 24V
			60/40	19,3	29	19		843	6,8	3/4	3WV DN20 KVS4 PROP 24V
			80/60	31,7	40	10		1400	10	3/4	3WV DN20 KVS4 PROP 24V
			90/70	37,9	45	8		1683	11,9	3/4	3WV DN20 KVS4 PROP 24V
35°C - 40% RH	26°C - 50% RH	28°C - 59% RH	7/12	10,9	22	79	63	1873	16,5	3/4	3WV DN20 KVS4 PROP 24V

TECHNICAL CHARACTERISTICS

Water coil data for units with horizontal discharge, hot water or reversible hot/chilled water coil DC/DFR

RHE 4500 HD - Airflow 4500 m ³ /h											
Outdoor Air (ODA)	Extract Air (ETA)	Supply Air (SUP) before DC coil	Water Temp. (°C)	Heating Power (kW)	Supply Air (SUP) after DC coil		Air Pressure Drop (Pa)	Water flow (l/h)	Water pressure drop (kPa)	Coil connection Ø (")	Recommended 3 way valve
					Temperature (°C)	Relative Humidity (%)					
-10°C - 90% RH	20°C - 50% RH	12°C - 47%RH	45/40	20,86	25	22	43	3611	4,5	3/4	3WV DN32 KVS16 PROP 24V
			60/40	23,7	27	20		1033	7,9	3/4	3WV DN20 KVS4 PROP 24V
			80/60	38,37	37	11		1692	12,2	3/4	3WV DN20 KVS4 PROP 24V
			90/70	45,67	41	9		2027	14,9	3/4	3WV DN20 KVS4 PROP 24V
35°C - 40% RH	26°C - 50% RH	29°C - 58% RH	7/12	12,89	23	77	95	2216	21,8	3/4	3WV DN20 KVS4 PROP 24V

RHE 6000 HD - Airflow 6000 m ³ /h												
Outdoor Air (ODA)	Extract Air (ETA)	Supply Air (SUP) before DC coil	Water Temp. (°C)	Type of coil	Heating Power (kW)	Supply Air (SUP) after DC coil		Air Pressure Drop (Pa)	Water flow (l/h)	Water pressure drop (kPa)	Coil connection Ø (")	Recommended 3 way valve
						Temperature (°C)	Relative Humidity (%)					
-10°C - 90% RH	20°C - 50% RH	13°C - 48%RH	45/40	DC/DFR	26	26	21	37	4.568	15	1	3WV DN25 KVS10 PROP 24V
				DFR4R	45	35	13	71	7.824	27,3	1 1/4	3WV DN40 KVS16 PROP 24V
			60/40	DC/DFR	29	28	20	37	1.279	5,5	1	3WV DN25 KVS6,3 PROP 24V
				DFR4R	53	39	10	71	2.347	9,4	1 1/4	3WV DN25 KVS6,3 PROP 24V
			80/60	DC/DFR	50	38	11	37	2.184	7	1	3WV DN25 KVS10 PROP 24V
				DFR4R	86	55	4	71	3.840	10,9	1 1/4	3WV DN25 KVS10 PROP 24V
			90/70	DC/DFR	60	42	9	37	2.643	8	1	3WV DN25 KVS10 PROP 24V
				DFR4R	-	-	-	-	-	-	-	-
35°C - 40% RH	26°C - 50% RH	28°C - 59% RH	7/12	DFR	17	22	78	84	2.847	9,7	1	3WV DN25 KVS10 PROP 24V
				DFR4R	29	16	92	137	5.011	14,7	1 1/4	3WV DN40 KVS16 PROP 24V

RHE 8000 HD - Airflow 8000 m ³ /h												
Outdoor Air (ODA)	Extract Air (ETA)	Supply Air (SUP) before DC coil	Water Temp. (°C)	Type of coil	Heating Power (kW)	Supply Air (SUP) after DC coil		Air Pressure Drop (Pa)	Water flow (l/h)	Water pressure drop (kPa)	Coil connection Ø (")	Recommended 3 way valve
						Temperature (°C)	Relative Humidity (%)					
-10°C - 90% RH	20°C - 50% RH	13°C - 48%RH	45/40	DC/DFR	36	27	21	32	6.311	15,7	1 1/4	3WV DN25 KVS10 PROP 24V
				DFR4R	60	35	12,5	60	10.605	16,5	1 1/2	3WV DN40 KVS25 PROP 24V
			60/40	DC/DFR	41	28	19	32	1.779	5,6	1 1/4	3WV DN25 KVS10 PROP 24V
				DFR4R	71	39	10	60	3.145	5,5	1 1/2	3WV DN40 KVS16 PROP 24V
			80/60	DC/DFR	69	38	11	32	3.024	7,2	1 1/4	3WV DN25 KVS10 PROP 24V
				DFR4R	117	56	4	60	5.189	7,3	1 1/2	3WV DN40 KVS16 PROP 24V
			90/70	DC/DFR	82	46	8	32	3.655	8,2	1 1/4	3WV DN25 KVS10 PROP 24V
				DFR4R	-	-	-	-	-	-	-	-
35°C - 40% RH	26°C - 50% RH	28°C - 59% RH	7/12	DFR	23	22	78	72	3.981	10,1	1 1/4	3WV DN25 KVS10 PROP 24V
				DFR4R	48	17	93	118	8.377	13,3	1 1/2	3WV DN40 KVS25 PROP 24V

RHE 10000 HD - Airflow 10000 m ³ /h												
Outdoor Air (ODA)	Extract Air (ETA)	Supply Air (SUP) before DC coil	Water Temp. (°C)	Type of coil	Heating Power (kW)	Supply Air (SUP) after DC coil		Air Pressure Drop (Pa)	Water flow (l/h)	Water pressure drop (kPa)	Coil connection Ø (")	Recommended 3 way valve
						Temperature (°C)	Relative Humidity (%)					
-10°C - 90% RH	20°C - 50% RH	13°C - 51%RH	45/40	DC/DFR	46	27	22	29	8.019	22	1 1/4	3WV DN32 KVS16 PROP 24V
				DFR4R	77	36	13	56	13.420	24,9	1 1/2	3WV DN40 KVS25 PROP 24V
			60/40	DC/DFR	52	28	20	29	2.290	6,1	1 1/4	3WV DN25 KVS10 PROP 24V
				DFR4R	92	40	10	56	4.028	6,2	1 1/2	3WV DN40 KVS16 PROP 24V
			80/60	DC/DFR	87	39	12	29	3.864	8,4	1 1/4	3WV DN32 KVS16 PROP 24V
				DFR4R	149	57	4	56	6.607	8,8	1 1/2	3WV DN40 KVS25 PROP 24V
			90/70	DC/DFR	105	44	8	29	4.662	9,9	1 1/4	3WV DN32 KVS16 PROP 24V
				DFR4R	-	-	-	-	-	-	-	-
35°C - 40% RH	26°C - 50% RH	28°C - 60% RH	7/12	DFR	30	22	80	68	5.227	13,2	1 1/4	3WV DN32 KVS16 PROP 24V
				DFR4R	64	17	93	111	11.025	19,6	1 1/2	3WV DN40 KVS25 PROP 24V

TECHNICAL CHARACTERISTICS

Hot/cold water coil data (DC-DFR) for horizontal discharge equipment (HD)

RHE 15000 HD - Airflow 15000 m ³ /h												
Outdoor Air (ODA)	Extract Air (ETA)	Supply Air (SUP) before DC coil	Water Temp. (°C)	Type of coil	Heating Power (kW)	Supply Air (SUP) after DC coil		Air Pressure Drop (Pa)	Water flow (l/h)	Water pressure drop (kPa)	Coil connection Ø (")	Recommended 3 way valve
						Temperature (°C)	Relative Humidity (%)					
-10°C - 90% RH	20°C - 50% RH	13°C - 51%RH	45/40	DC/DFR	66	26	23	25	9.578	47,3	1 1/2	3WV DN32 KVS16 PROP 24V
			60/40	DC/DFR	80	29	19	26	3.493	10,6		3WV DN32 KVS16 PROP 24V
			80/60	DC/DFR	129	39	11	26	5.714	17,5		3WV DN32 KVS16 PROP 24V
			90/70	DC/DFR	154	43	9	26	6.835	22,6		3WV DN32 KVS16 PROP 24V
35°C - 40% RH	26°C - 50% RH	28°C - 60% RH	7/12	DFR	45	22	78	61	7.795	38,9	1 1/2	3WV DN32 KVS16 PROP 24V
				DFR4R	88	18	88	105	15.079	40,6		3WV DN40 KVS25 PROP 24V

TECHNICAL CHARACTERISTICS

Direct expansion coils (DX) data- Condensation

Fluid R410A - Condensation T° 51°C

Outdoor Air (ODA)	Extract Air (ETA)	Supply Air (SUP) before DX coil	Cooling Power (kW)	Supply Air (SUP) after DX coil (°C)	Relative Humidity Supply Air (% RH)	Air Pressure Drop (Pa)	Volume coil (dm³)	DX Coil connection Ø (mm)	
-10°C 90% HR	20°C 50% HR	RHE 700 HD - Airflow 700 m³/h							
		15°C 47%HR	4	33	16	11	0,5	9,5/9,5	
		RHE 1300 HD - Airflow 1.600 m³/h							
		12°C 50%HR	9	33	15	49	0,7	12,7/15,8	
		RHE 1900 HD - Airflow 2.100 m³/h							
		13°C 51%HR	13	34	15	54	1,0	12,7/15,8	
		RHE 2500 HD - Airflow 2.800 m³/h							
		13°C 51%HR	17	33	15	46	1,5	12,7/22,2	
		RHE 3500 HD - Airflow 3.500 m³/h							
		13°C 51%HR	25	34	15	43	2,1	12,7/22,2	
		RHE 4500 HD - Airflow 4.500 m³/h							
		11°C 53%HR	29	32	15	67	2,1	12,7/22,2	
		RHE 6000 HD - Airflow 6.000 m³/h							
		13°C 50%HR	42	33	16	64	4,7	12,7/28,5	
RHE 8000 HD - Airflow 8.000 m³/h									
13°C 51%HR	49	31	17	38	4,8	2x15,8/2x22,2			
RHE 10000 HD - Airflow 10.000 m³/h									
13°C 51%HR	59	30	17	35	6,1	2x22,2/2x28,5			

Direct expansion coils (DX) data- Evaporation

Fluid R410A - Evaporation T° 6,5°C

Outdoor Air (ODA)	Extract Air (ETA)	Supply Air (SUP) before DX coil	Cooling Power (kW)	Supply Air (SUP) after DX coil (°C)	Relative Humidity Supply Air (% RH)	Air Pressure Drop (Pa)	Volume coil (dm³)	DX Coil connection Ø (mm)	
35°C 40% HR	26°C 50% HR	RHE 700 HD - Airflow 700 m³/h							
		26°C 61%HR	2	18	81	15	0,5	9,5/9,5	
		RHE 1300 HD - Airflow 1.600 m³/h							
		27°C 57%HR	4	18	78	67	0,7	12,7/15,8	
		RHE 1900 HD - Airflow 2.100 m³/h							
		27°C 57%HR	6	18	81	73	1,0	12,7/15,8	
		RHE 2500 HD - Airflow 2.800 m³/h							
		27°C 57%HR	8	18	82	62	1,5	12,7/22,2	
		RHE 3500 HD - Airflow 3.500 m³/h							
		27°C 57%HR	11	18	82	58	2,1	12,7/22,2	
		RHE 4500 HD - Airflow 4.500 m³/h							
		27°C 57%HR	13	19	80	92	2,1	12,7/22,2	
		RHE 6000 HD - Airflow 6.000 m³/h							
		27°C 57%HR	18	18	80	88	4,7	12,7/28,5	
RHE 8000 HD - Airflow 8.000 m³/h									
27°C 57%HR	21	19	77	56	4,8	2x15,8/2x22,2			
RHE 10000 HD - Airflow 10.000 m³/h									
27°C 57%HR	25	20	76	50	6,1	2x22,2/2x28,2			

ELECTRICAL CHARACTERISTICS

All models (except DI model)

Model	Heat exchanger motor (1)			Fan motor (2)				Global unit		
	Power supply voltage (V)	Nominal power (W)	Current (A)	Voltage (V)	Frequency (Hz)	Max. absorbed power (W)	Current (A)	Power supply voltage (V)	Total supply power (kW)	Total current max. (A)
RHE 700	230 V single phase	40	0,2	230 V single phase	50/60	200	1,6	230 V single phase	1	4,2
RHE 1300	230 V single phase	40	0,2	230 V single phase	50/60	700	3	230 V single phase	2	7,3
RHE 1900	230 V single phase	40	0,2	230 V single phase	50/60	715	3,1	230 V single phase	2	7,5
RHE 2500	400 V three phase	55	0,28	400 V three phase	50/60	1000	1,6	400 V three phase + N	3	4,5
RHE 3500	400 V three phase	55	0,28	400 V three phase	50/60	1000	1,7	400 V three phase + N	3	4,6
RHE 4500	400 V three phase	55	0,28	400 V three phase	50/60	1850	2,9	400 V three phase + N	4	7,2
RHE 6000	400 V three phase	55	0,28	400 V three phase	50/60	1850	2,9	400 V three phase + N	4	7,2
RHE 8000	400 V three phase	120	0,35	400 V three phase	50/60	2730	4,2	400 V three phase + N	6	9,8
RHE 10000	400 V three phase	120	0,35	400 V three phase	50/60	3000	4,6	400 V three phase + N	6,5	10,5
RHE 15000	400 V three phase	180	1,11	400 V three phase	50/60	5000	7,7	400 V three phase + N	12,0	18,5

(1) 1 wheel drive motor per unit (2) Data for 1 fan motor - Each unit has 2 fan motors.

DI Models

Model	Heat exchanger motor (1)			Fan motor (2)				Electric coil		Global unit		
	Power supply voltage (V)	Nominal power (W)	Current (A)	Voltage (V)	Frequency (Hz)	Max. absorbed power (W)	Current (A)	Total supply power (kW)	Total current max. (A)	Power supply voltage (V)	Total supply power (kW)	Total current max. (A)
RHE 700	230 V single phase	40	0,2	230 V single phase	50/60	200	1,6	3	13,1	230 V single phase	4	17,3
RHE 1300	230 V single phase	40	0,2	230 V single phase	50/60	700	3	4	17,4	230 V single phase	6	24,6
RHE 1900	230 V single phase	40	0,2	230 V single phase	50/60	715	3,1	8	34,8	230 V single phase	10	42,2
RHE 2500	400 V three phase	55	0,28	400 V three phase	50/60	1000	1,6	12	17,3	400 V three phase + N	15	21,8
RHE 3500	400 V three phase	55	0,28	400 V three phase	50/60	1000	1,7	15	21,7	400 V three phase + N	18	26,3
RHE 4500	400 V three phase	55	0,28	400 V three phase	50/60	1850	2,9	15	21,7	400 V three phase + N	19	29
RHE 6000	400 V three phase	55	0,28	400 V three phase	50/60	1850	2,9	24	34,7	400 V three phase + N	28	41,9
RHE 8000	400 V three phase	120	0,35	400 V three phase	50/60	2730	4,2	36	52	400 V three phase + N	42	61,8
RHE 10000	400 V three phase	120	0,35	400 V three phase	50/60	3000	4,6	48	69,3	400 V three phase + N	55	79,8
RHE 15000	400 V three phase	180	1,1	400 V three phase	50/60	5000	7,7	-	-	400 V three phase + N	12	18,5
								-	-	400 V three phase	72	104

(1) 1 wheel drive motor per unit (2) Data for 1 fan motor - Each unit has 2 fan motors.

Electric heater coil	
Unit power (kW)	Unit current (A)
3	13,1
4	17,4
8	34,8
12	17,3
15	21,7
15	21,7
24	34,7
36	52,0
48	69,3

SCHEMATIC DIAGRAM

RHE DC-DFR
Control system for water coil

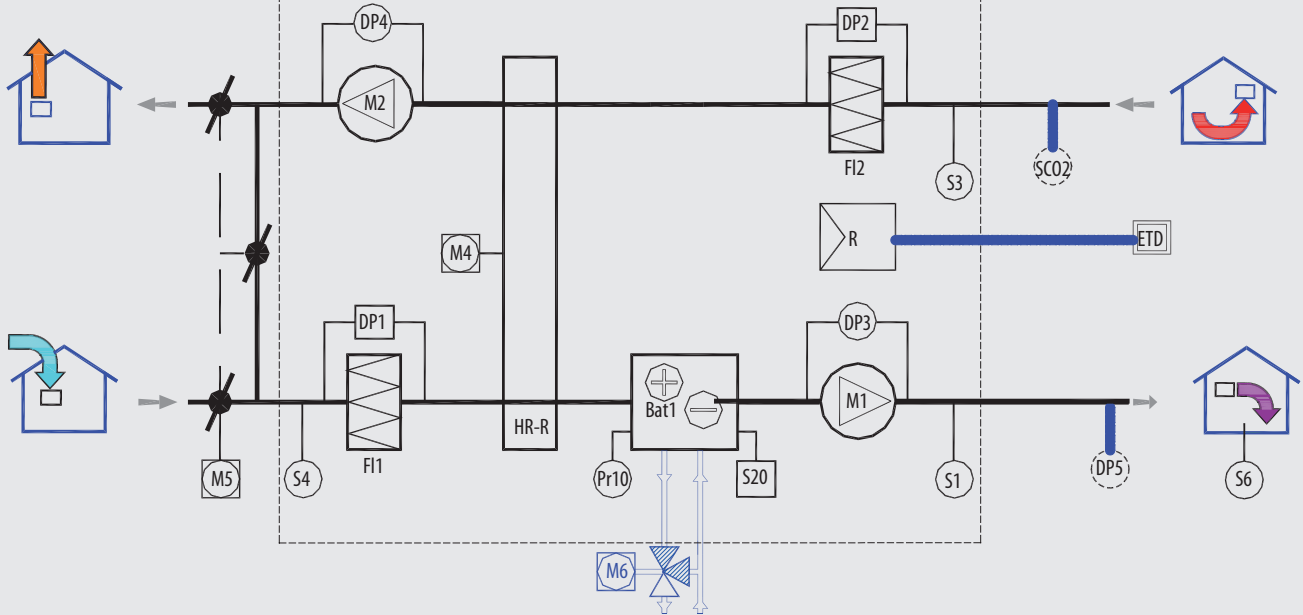

RHE DI
Control system for electric heater coil

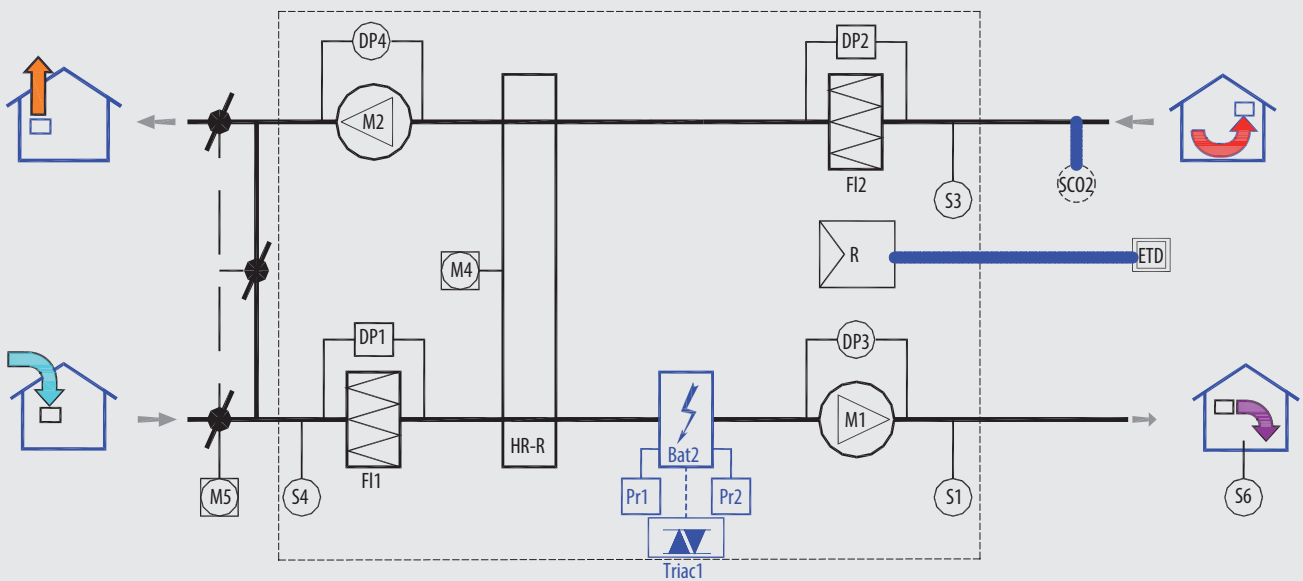

M1	Supply air fan motor	SCO2	Air quality sensor (accessory)	Pr10	Antifrost sensor
M2	Exhaust air fan motor	HR-R	Rotary wheel	Pr1/Pr2	Security thermostat (manu/auto)
M4	Rotary exchanger motor	Fi1	Outdoor air filters	S20	Thermostat change-over
M5	Fresh air motorized damper (accessory)	Fi2	Extract air filter	Bat 1	Water coil
M6	3 way valve actuator (accessory)	DP1	Outdoor air filter pressure guard	Bat 2	Electrical heating resistance
S1	Supply air T° sensor	DP2	Extract air filter pressure guard	R	Controller CORRIGO E28
S3	Extract air T° sensor	DP3	Supply air fan pressure transmitter	ETD	Room touch screen display
S4	Outdoor T° sensor	DP4	Exhaust air fan pressure transmitter		
S6	Room T° sensor	DP5	Duct pressure transmitter (accessory)		

SCHEMATIC DIAGRAM

RHE DC/DF (models 6000, 8000, 10000 and 15000)
Control system for 2 water coils

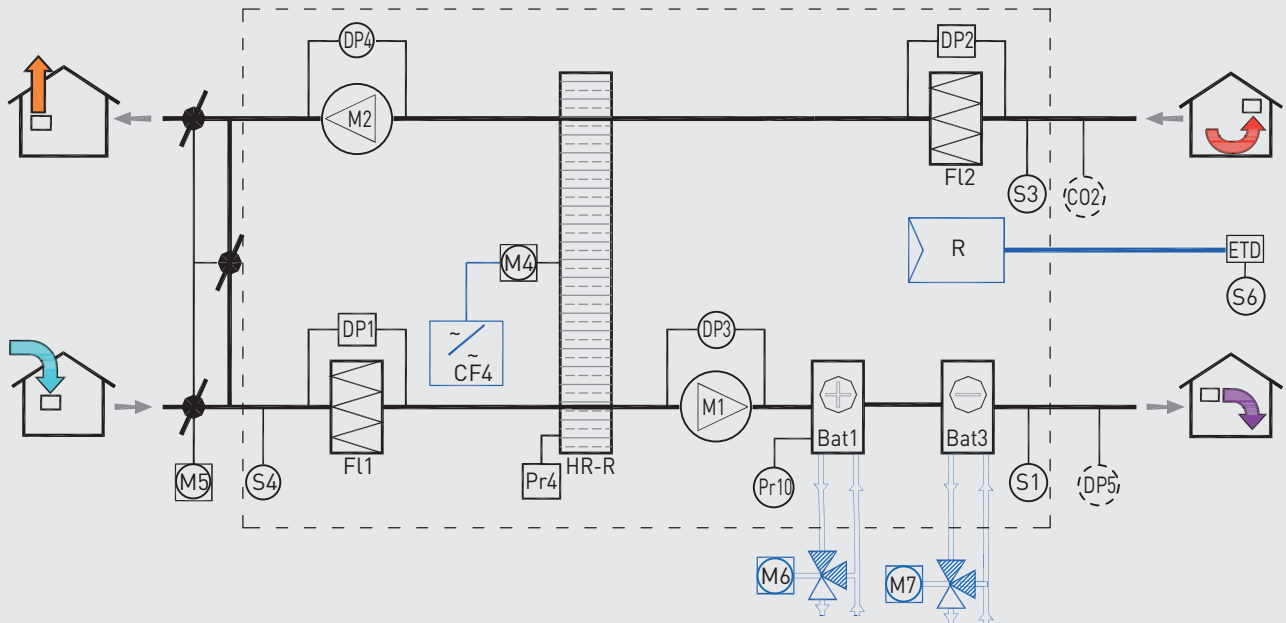

RHE DX
Control system for direct expansion coils

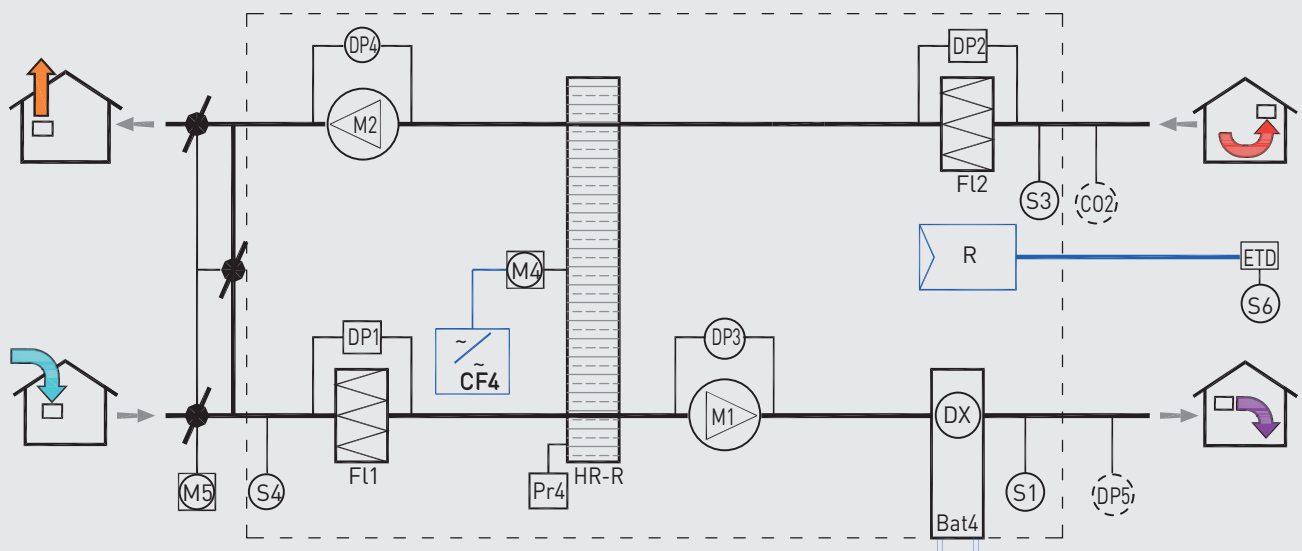

- | | | | | | |
|----|--|------|---|---------|---------------------------------------|
| M1 | Supply air fan motor | SC02 | Air quality sensor (accessory) | DP4 | Exhaust air fan pressure transmitter |
| M2 | Exhaust air fan motor | HR-R | Rotary wheel | DP5 | Duct pressure transmitter (accessory) |
| M4 | Rotary exchanger motor | Pr4 | Tachometer (rotation control of the exchanger) | Pr10 | Antifrost sensor |
| M5 | Fresh air motorized damper (accessory) | CF4 | Frequency converter (enthalpic or adsorption exchanger) | Pr1/Pr2 | Security thermostat (manu/auto) |
| M6 | 3 way valve actuator (accessory) | Fi1 | Outdoor air filters | S20 | Thermostat change-over |
| M7 | 3-way motorised valve (accessory) | Fi2 | Extract air filter | Bat 1 | Hot water coil |
| S1 | Supply air T° sensor | DP1 | Outdoor air filter pressure guard | Bat 2 | Electrical heating resistance |
| S3 | Extract air T° sensor | DP2 | Extract air filter pressure guard | Bat 3 | RHE DC/DF chilled water coil |
| S4 | Outdoor T° sensor | DP3 | Supply air fan pressure transmitter | Bat 4 | DX direct expansion coil |
| S6 | Room T° sensor | | | R | Controller CORRIGO E28 |
| | | | | ETD | Room touch screen display |

DIMENSIONS (mm)

RHE VDR 700 a 3500

Vertical discharge

Inner side connections
on the right

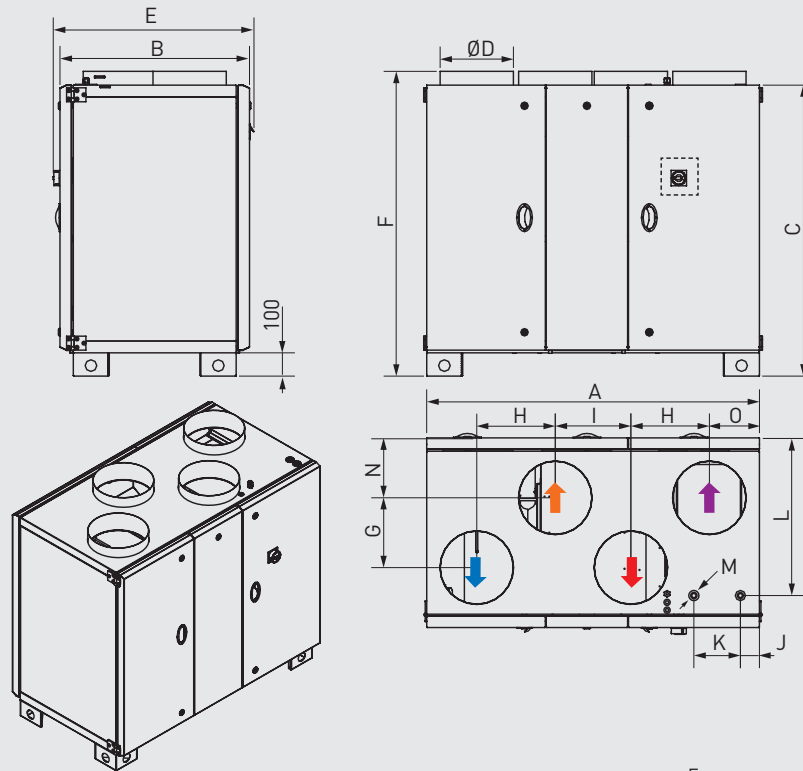

RHE VDL 700 a 3500

Vertical discharge

Inner side connections
on the left

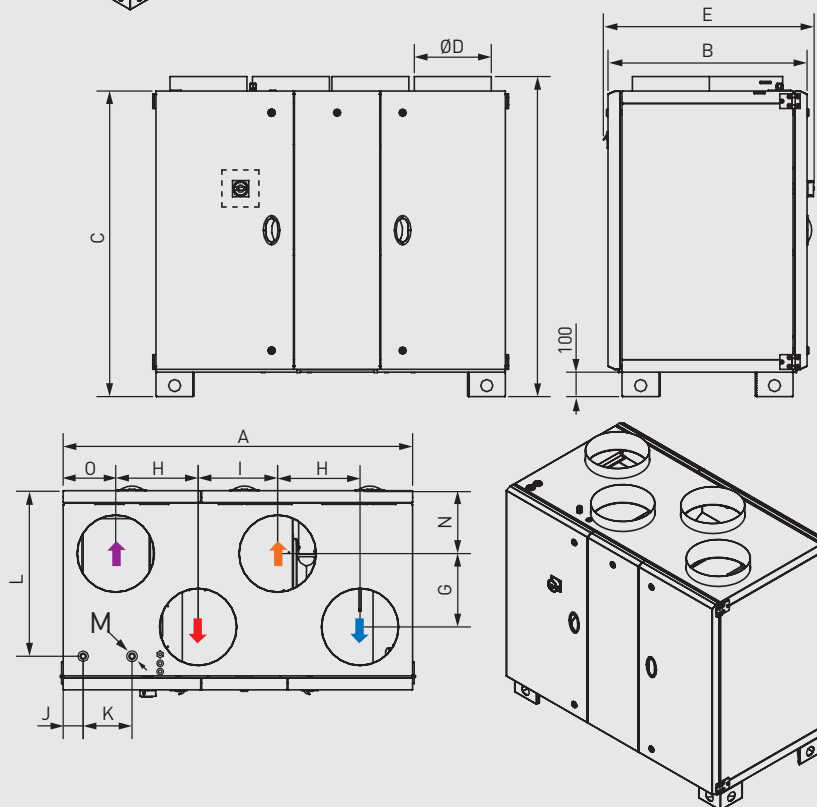

- Outdoor air duct connection
- Supply air duct connection
- Extract air duct connection
- Exhaust air duct connection
- Control position

Model	A	B	C	ØD	E	F	G	H	I	J	K	L	M	N	O	Weight (kg)
RHE 700/1300 VD	1285	715	1125	250	750	1185	200	310	300	101	195	569	1/2"	258	183	196
RHE 1900 VD	1490	815	1250	315	850	1309	300	355	350	90	255	689	1/2"	258	215	257
RHE 2500 VD	1740	965	1350	355	1000	1410	400	420	400	105	307	825	3/4"	283	250	328
RHE 3500 VD	1900	1125	1530	450	1156	1590	450	460	400	105	367	985	3/4"	338	290	395

DIMENSIONS (mm)

RHE VDL 4500

Vertical discharge

Inner side connections on the right

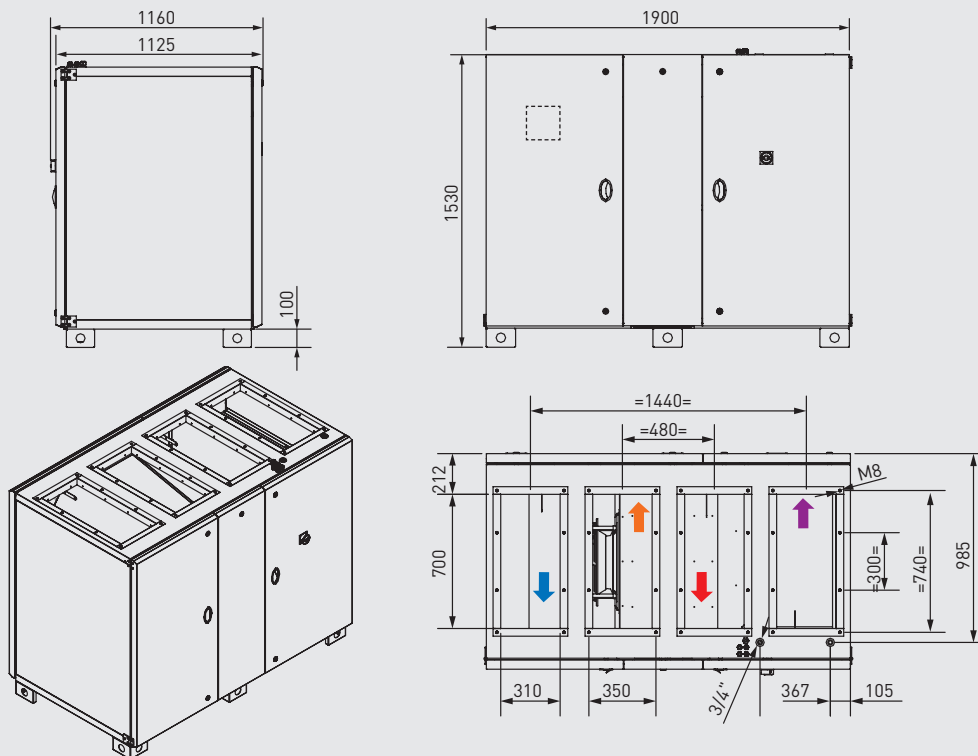

RHE VDL 4500

Vertical discharge

Inner side connections on the left

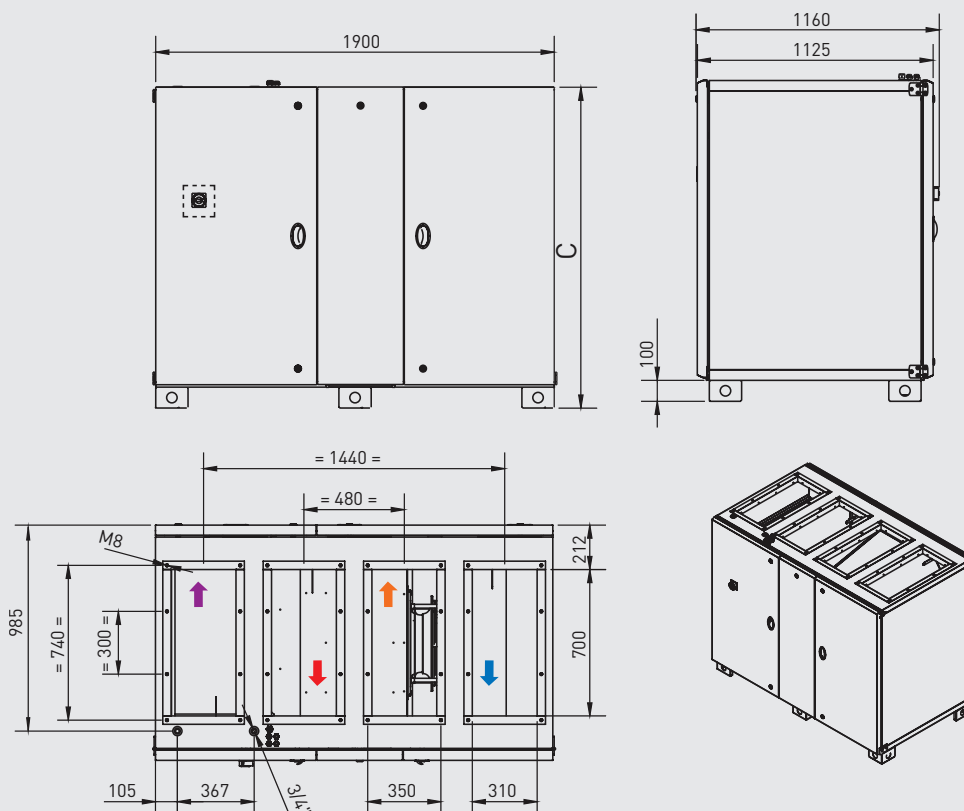

- Outdoor air duct connection
- Supply air duct connection
- Extract air duct connection
- Exhaust air duct connection
- Control position

DIMENSIONS (mm)

RHE HDR 700 to 4500
Horizontal discharge
 Right side access.

- Outdoor air duct connection
- Supply air duct connection
- Extract air duct connection
- Exhaust air duct connection
- Control position

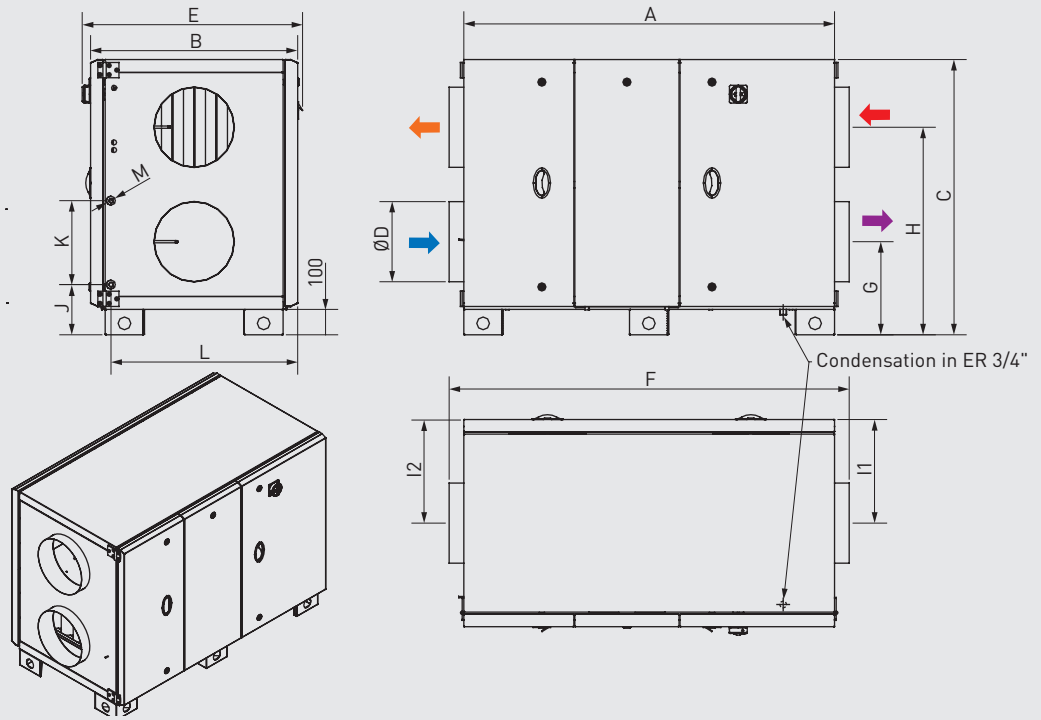

RHE HDL 700 to 4500
Horizontal discharge
 Left side access.

- Outdoor air duct connection
- Supply air duct connection
- Extract air duct connection
- Exhaust air duct connection
- Control position

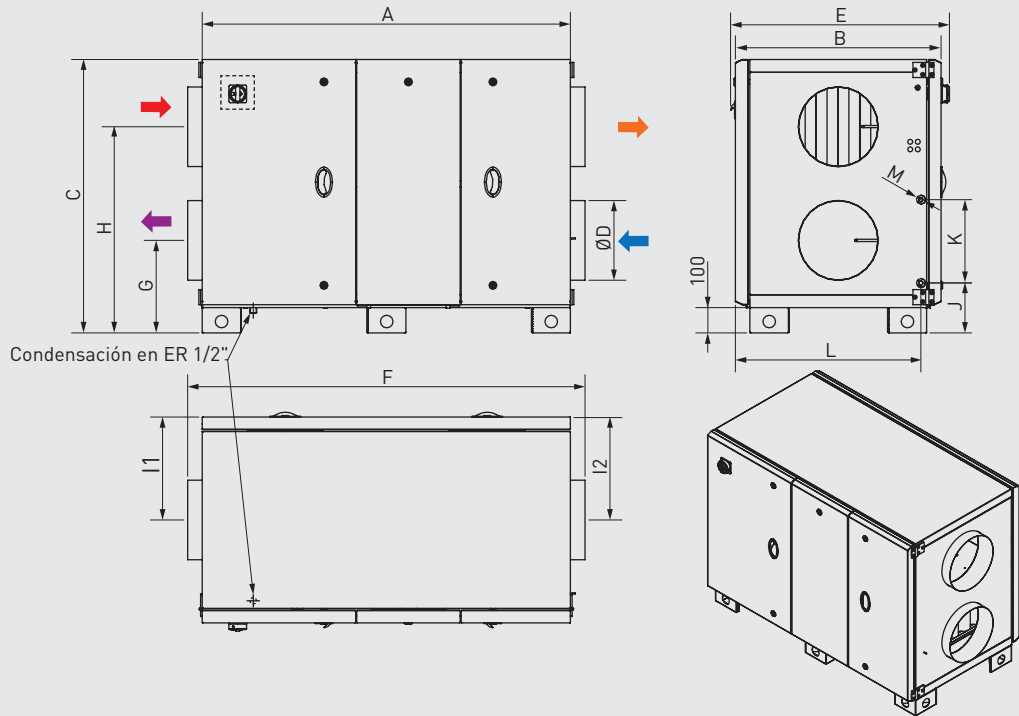

Model	A	B	C	ØD	E	F	G	H	I1	I2	J	K	L	M	Weight (kg)
RHE 700/1300 HD	1309	715	983	315	763	1425	329	754	327,5	357,5	210	255	625	1/2"	173
RHE 1900 HD	1459	815	1085	355	851	1575	356	826	407,5	407,5	194	337	719	3/4"	217
RHE 2500 HD	1558	965	1183	400	1000	1675	379	904	482,5	482,5	204	367	869	3/4"	242
RHE 3500 HD	1558	1125	1363	450	1160	1675	436	1026	562,5	562,5	204	457	1030	3/4"	323
RHE 4500 HD	1558	1125	1363	500	1160	1675	436	1026	562,5	562,5	204	457	1030	3/4"	326

HIGH EFFICIENCY HEAT RECOVERY UNITS WITH ROTARY WHEEL

RHE Series



DIMENSIONES (mm)

RHE HDR 6000 a 10000
Horizontal discharge
 Inner side connections
 on the right

These models are supplied in 2 modules,
 easily joined at the time of installation.

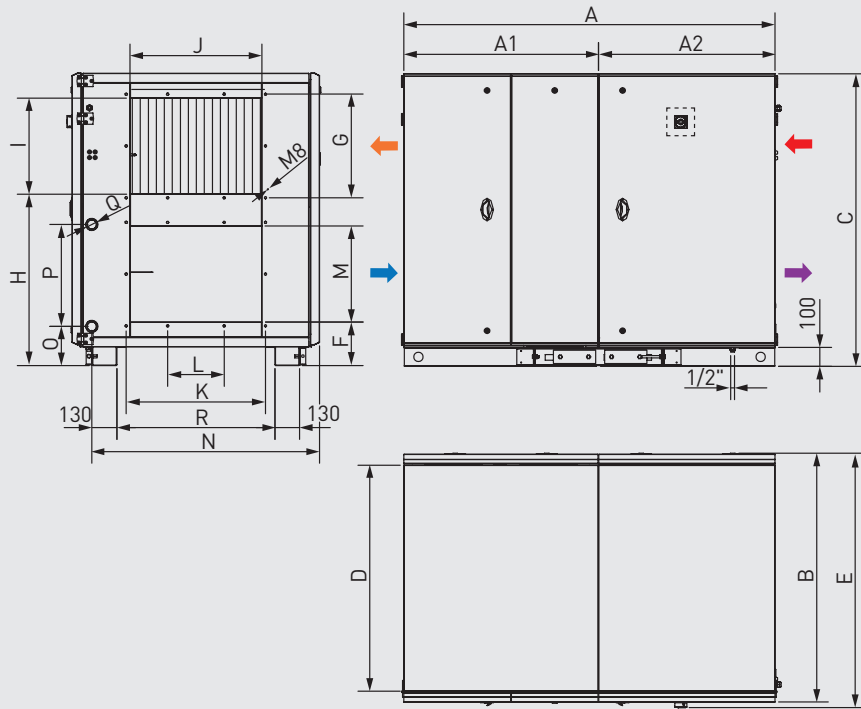

RHE 6000 DX
 with direct expansion coil

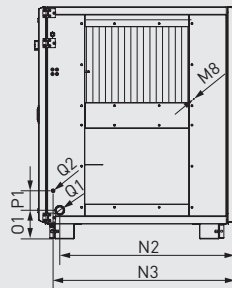

RHE 8000/10000 DX
 with direct expansion coil

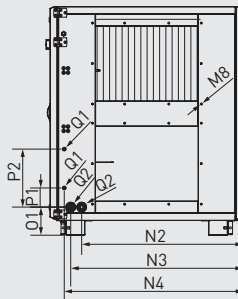

RHE DC/DF
 with reversible hot/cold water coil

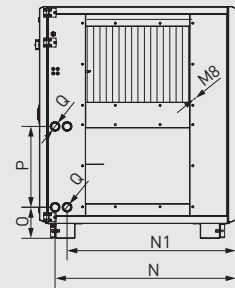

- ➡ Outdoor air duct connection
- ➡ Supply air duct connection
- ➡ Extract air duct connection
- ➡ Exhaust air duct connection
- Control position

Model	A	A1*	A2	B	C	D	E	F	G	H	I	J	K
RHE 6000 HD	1972	1034	938	1315	1553	1200	1350	235	550	915	510	700	740
RHE 8000 HD	2112	1114	998	1565	1803	1450	1600	245	650	1050	610	900	940
RHE 10000 HD	2412	1263	1149	1735	1971	1620	1770	285	650	1175	610	1100	1140

* To take into account: 50mm of one module are fit into the other one.

Model	L	M	N	N1	N2	N3	O	O1	P	P1	Q	Q1	Q2	R
RHE 6000 HD	300	510	1210	1131	1174	1218	208	191	541	130	1"	12	28	840
RHE 8000 HD	300	610			1389	1438	216	179	653	206	1"1/4	22	28	1090
RHE 10000 HD	600	610	1614	1514	1559	1616	214	195	743	235	1"1/4	22	35	1260

* To take into account: 50mm of one module are fit into the other one.

Models	Weight (kg)																	
	Versions																	
	D			DI			DC			DFR			DC/DF			DX		
A1	A2	A1 + A2	A1	A2	A1 + A2	A1	A2	A1 + A2	A1	A2	A1 + A2	A1	A2	A1 + A2	A1	A2	A1 + A2	
RHE 6000 HD	345	224	569	345	251	596	345	245	590	345	252	597	345	273	618	345	262	607
RHE 8000 HD	457	285	742	457	322	779	457	313	770	457	323	780	457	352	809	457	337	794
RHE 10000 HD	550	354	904	550	398	948	550	388	938	550	400	950	550	434	984	550	416	966

DIMENSIONES (mm)

RHE HDL 6000 a 10000

Horizontal discharge

Inner side connections on the left

These models are supply in 2 modules, which easily join in the moment of facility.

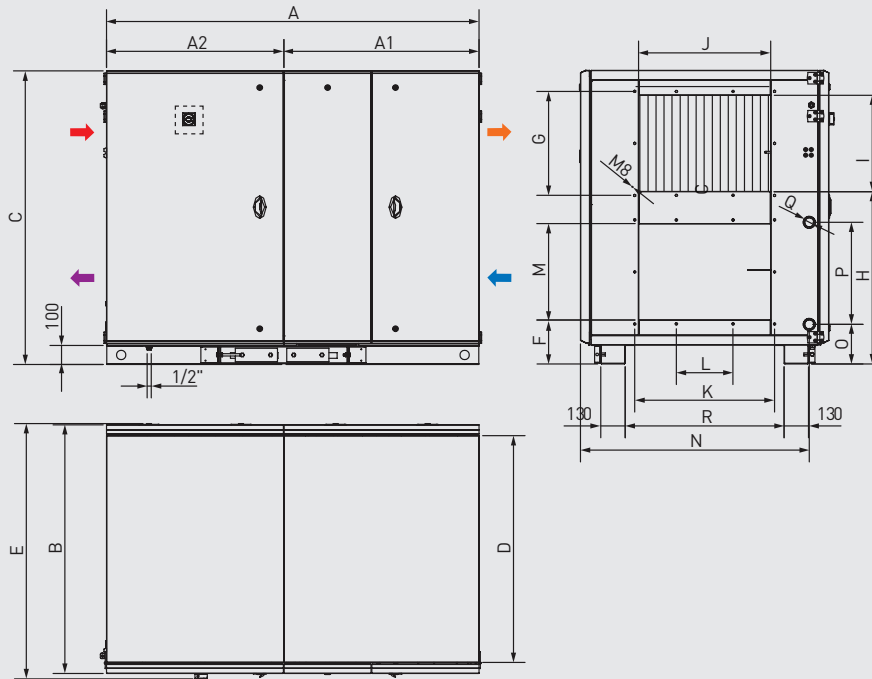

RHE 6000 DX with direct expansion coil

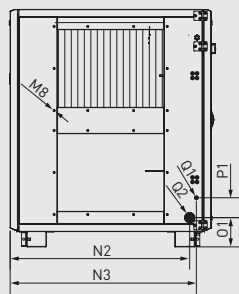

RHE 8000/10000 DX with direct expansion coil

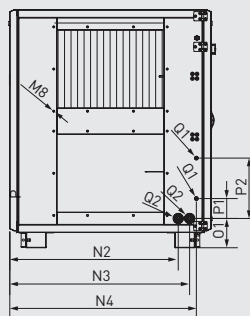

RHE DC/DF with reversible hot/cold water coil

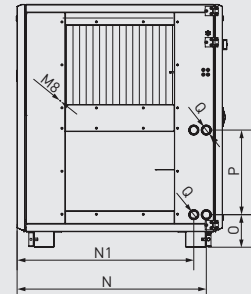

- Outdoor air duct connection
- Supply air duct connection
- Extract air duct connection
- Exhaust air duct connection
- Control position

Model	A	A1*	A2	B	C	D	E	F	G	H	I	J	K
RHE 6000 HD	1972	1034	938	1315	1553	1200	1350	235	550	915	510	700	740
RHE 8000 HD	2112	1114	998	1565	1803	1450	1600	245	650	1050	610	900	940
RHE 10000 HD	2412	1263	1149	1735	1971	1620	1770	285	650	1175	610	1100	1140

* To take into account: 50mm of one module are fit into the other one.

Model	L	M	N	N1	N2	N3	N4	O	O1	P	P1	P2	Q*	Q1	Q2	R
RHE 6000 HD	300	510	1210	1131	1174	1218	-	208	213	541	109	-	1"11/4"	12,7	28,5	840
RHE 8000 HD	300	610	1434	1334	1364	1410	1410	216	213	653	172	422	1"1/4(1"1/2)	15,8	22,2	1090
RHE 10000 HD	600	610	1614	1514	1580	1580	1610	214	213	743	217	522	1"1/4(1"1/2)	22,2	28,5	1260

* To take into account: 50mm of one module are fit into the other one.

Model	Weight (kg)																	
	Versions																	
	D			DI			DC			DFR			DC/DF			DX		
A1	A2	A1 + A2	A1	A2	A1 + A2	A1	A2	A1 + A2	A1	A2	A1 + A2	A1	A2	A1 + A2	A1	A2	A1 + A2	
RHE 6000 HD	345	224	569	345	251	596	345	245	590	345	252	597	345	273	618	345	262	607
RHE 8000 HD	457	285	742	457	322	779	457	313	770	457	323	780	457	352	809	457	337	794
RHE 10000 HD	550	354	904	550	398	948	550	388	938	550	400	950	550	434	984	550	416	966

DIMENSIONS (Mm)

RHE HDR 15000

Horizontal discharge.
Right side access.

These models are supplied with 2 modules, which are easily fit together in the moment of installation.

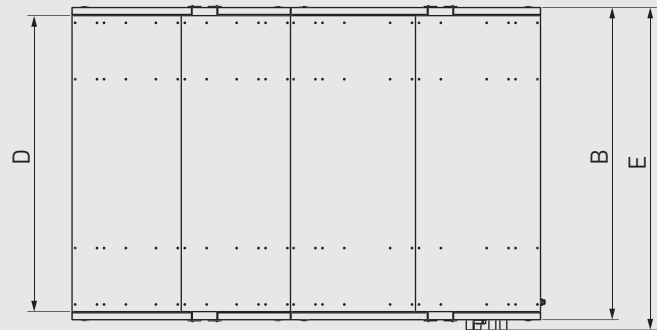
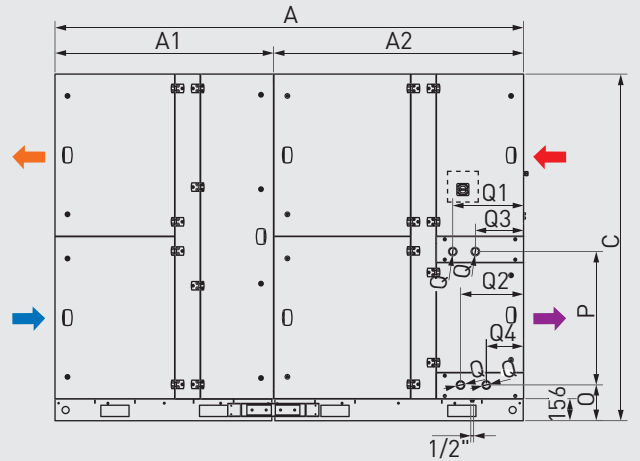
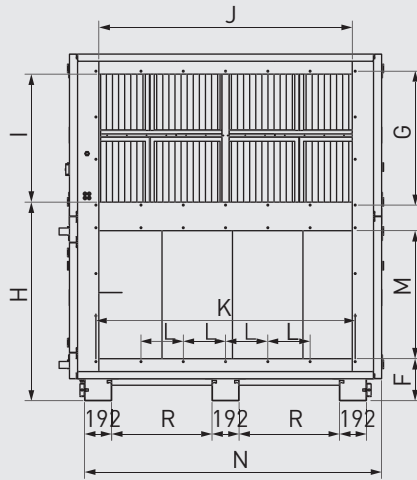

- Outdoor air duct connection
- Supply air duct connection
- Extract air duct connection
- Exhaust air duct connection
- Control position

RHE DC and DFR

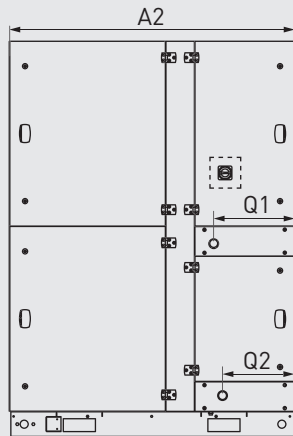

RHE DFR4R

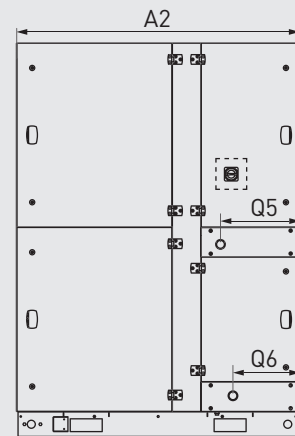

Model	A	A1*	A2	B	C	D	E	F	G	H	I	J	K
RHE 15000 HD	3325	1552	1774	2215	2460	2100	2288	298	950	1409	908	1798	1840

* To take into account: 50mm of one module are fit into the other one.

Model	L	M	N	N1	O	P	Q	Q1	Q2	Q3	Q4	Q5	Q6	R
RHE 15000 HD	300	908	2107	254	254	947	1"1/2	502	447	342	264	498	420	712

Model	Weight (kg)														
	Versions														
	D			DI			DC			DFR			DC/DF		
A1	A2	A1 ↓ A2	A1	A2	A1 ↓ A2	A1	A2	A1 ↓ A2	A1	A2	A1 ↓ A2	A1	A2	A1 ↓ A2	
RHE 15000 HD	930	710	1640	930	800	1730	930	750	1680	930	790	1720	930	830	1760

DIMENSIONES (mm)

RHE HDL 15000

Horizontal discharge

Inner side connections to left

These models are supplied in 2 modules, easily joined at the time of installation.

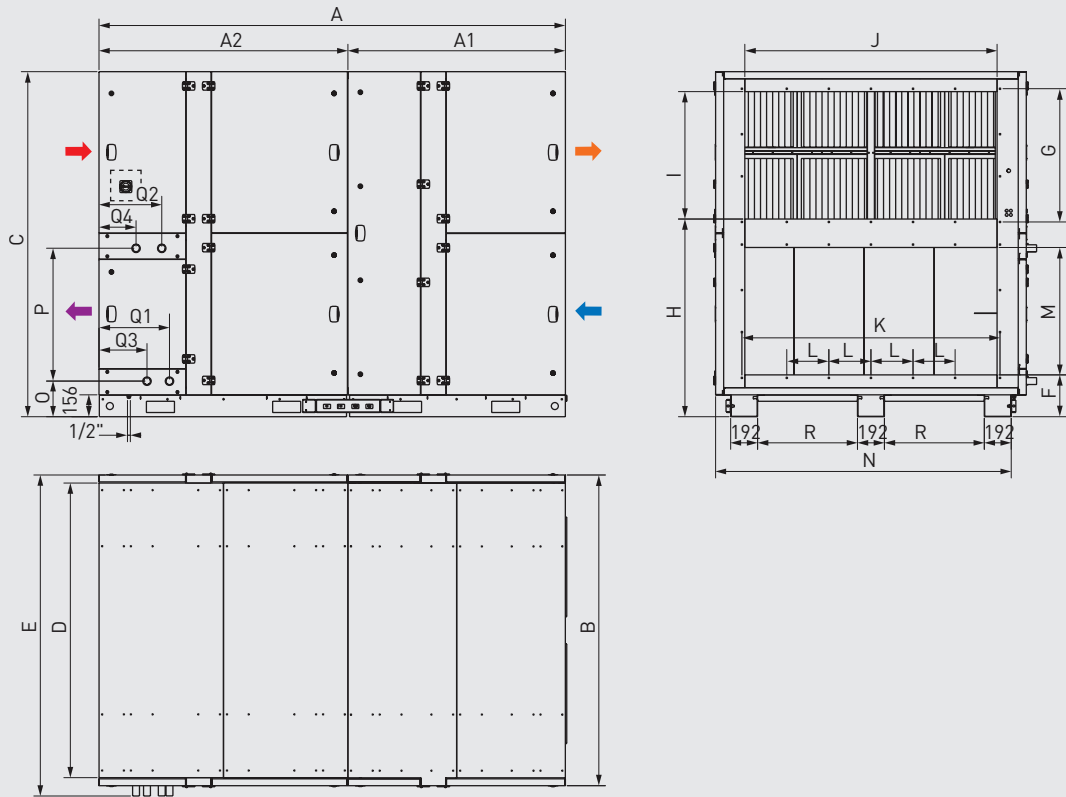

RHE DC and DFR

RHE DFR4R

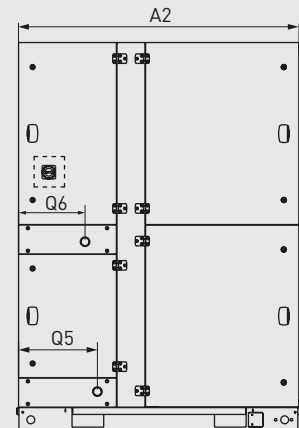
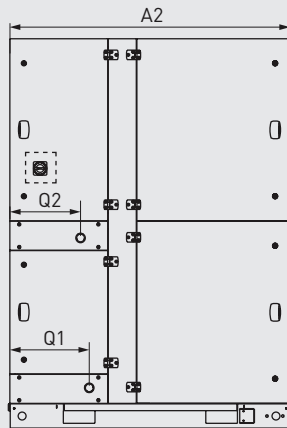

- Outdoor air duct connection
- Supply air duct connection
- Extract air duct connection
- Exhaust air duct connection
- Control position

Model	A	A1*	A2	B	C	D	E	F	G	H	I	J	K
RHE 15000 HD	3325	1552	1774	2215	2460	2100	2288	298	950	1409	908	1798	1840

* To take into account: 50mm of one module are fit into the other one.

Model	L	M	N	N1	O	P	Q	Q1	Q2	Q3	Q4	Q5	Q6	R
RHE 15000 HD	300	908	2107	254	254	947	1 1/2	502	447	342	264	498	420	712

Model	Weight (kg)														
	Versions														
	D			DI			DC			DFR			DC/DF		
	A1	A2	A1 + A2	A1	A2	A1 + A2	A1	A2	A1 + A2	A1	A2	A1 + A2	A1	A2	A1 + A2
RHE 15000 HD	930	710	1640	930	800	1730	930	750	1680	930	790	1720	930	830	1760

DIMENSIONS (mm)

Outdoor version
Right side access.

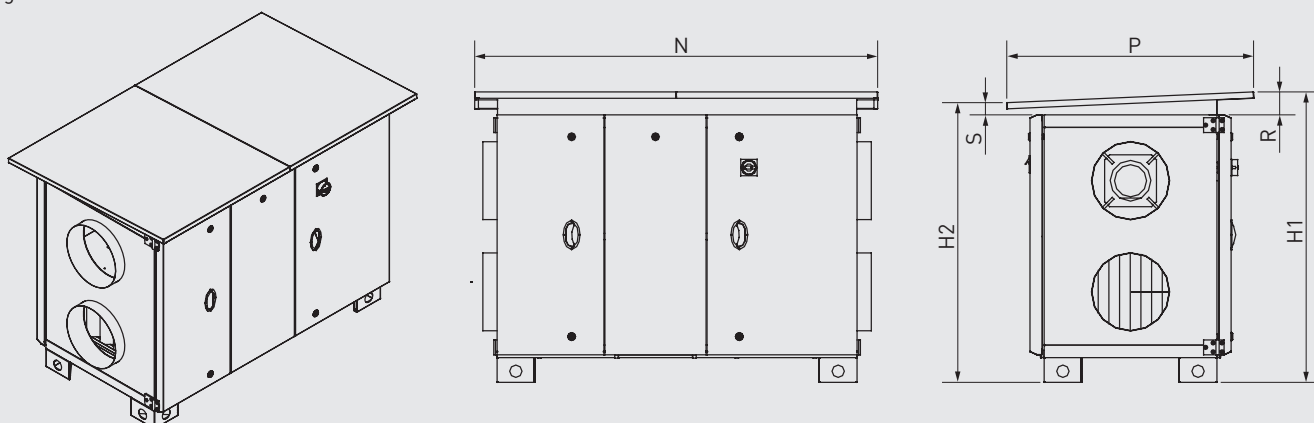

Control position

Outdoor version
Left side access.

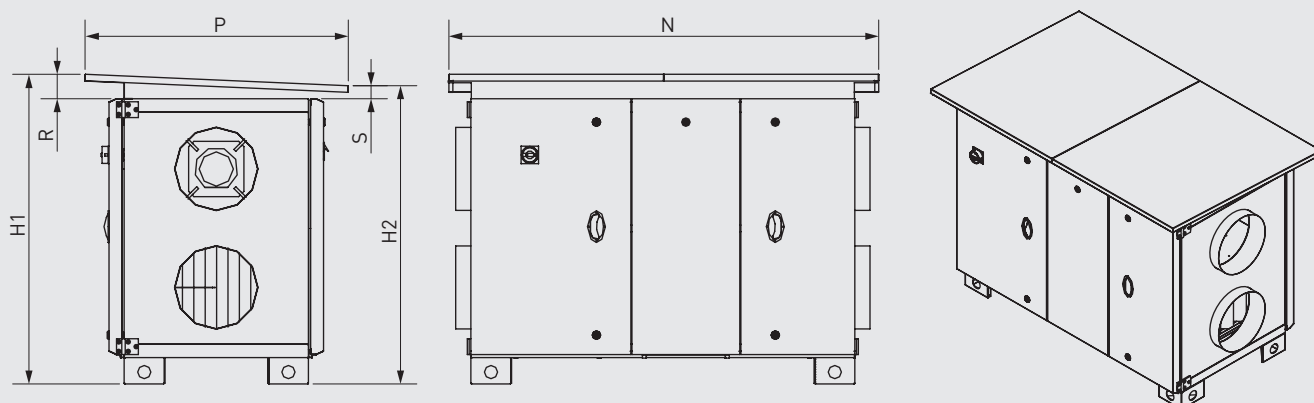

Control position

Model	H1	H2	N	P	R	S	Weight (Kg)
RHE 700/1300 HD OI	1068	1036	1568	900	85	54	192
RHE 1900 HD OI	1171	1136	1719	1000	89	54	239
RHE 2500 HD OI	1276	1236	1818	1150	94	54	268
RHE 3500/4500 HD OI	1462	1416	1818	1309	99	54	355
RHE 6000 HD OI	1659	1606	2232	1500	106	54	570
RHE 8000 HD OI	1917	1856	2372	1750	115	54	838
RHE 10000 HD OI	2093	2026	2672	1920	122	54	1034
RHE 15000 HD OI	2500	2500	3325	2215	-	40	

ETD
Remote control with
touch display

It is provided with 10m
cable and equipped with
RJ10 4P 4C connector to
connect with the control
(a cable until 100m length
can be used, if necessary)

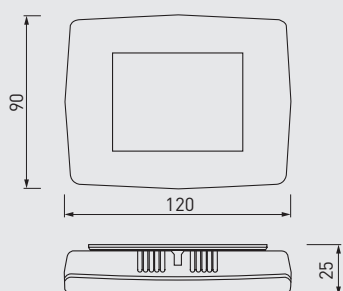

PERFORMANCE CURVE

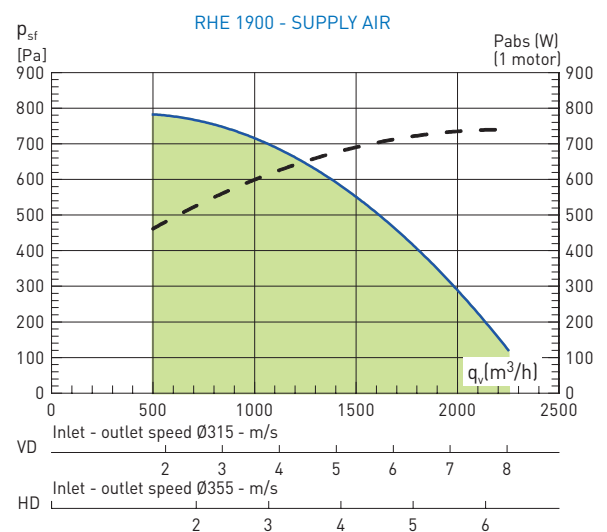
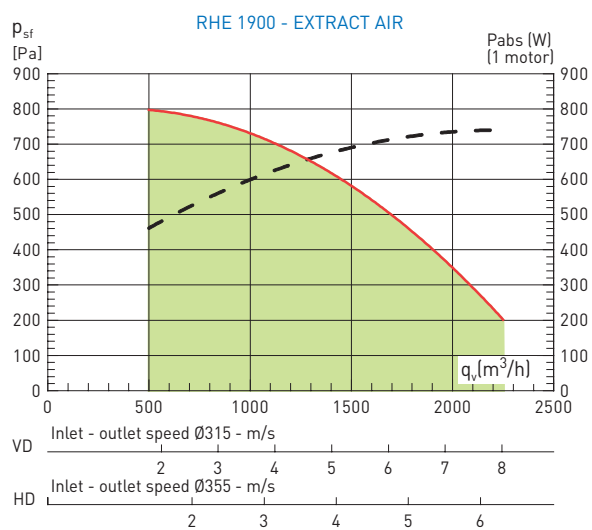
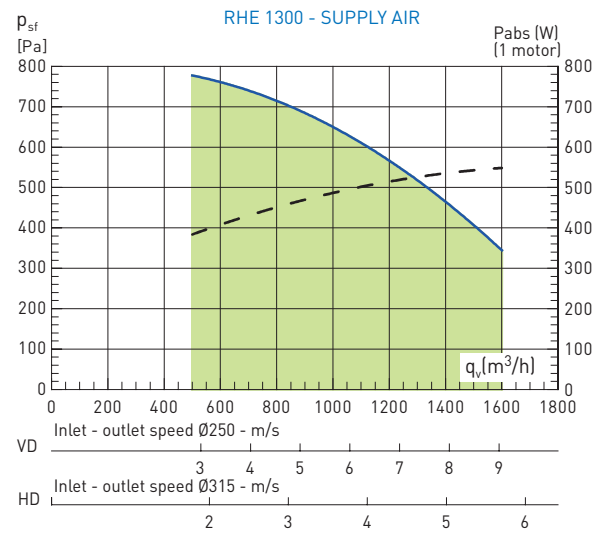
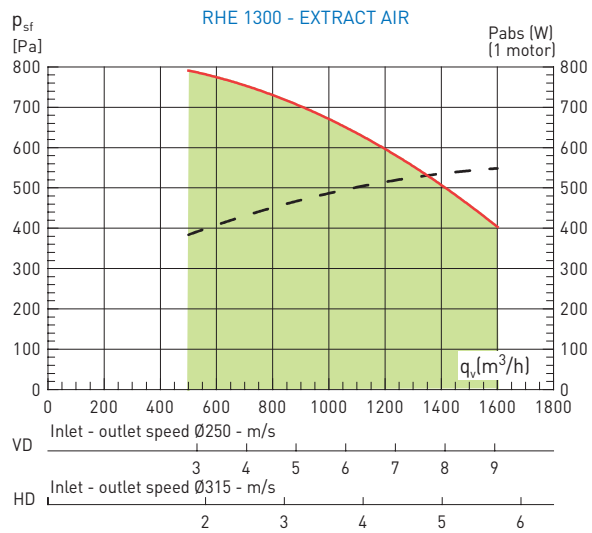
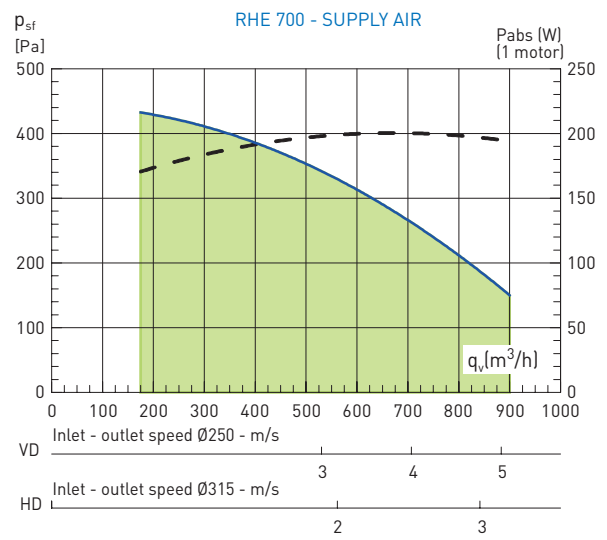
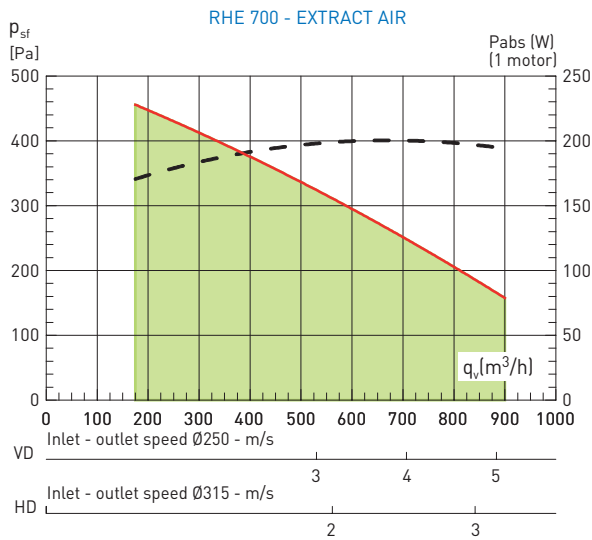

PERFORMANCE CURVE

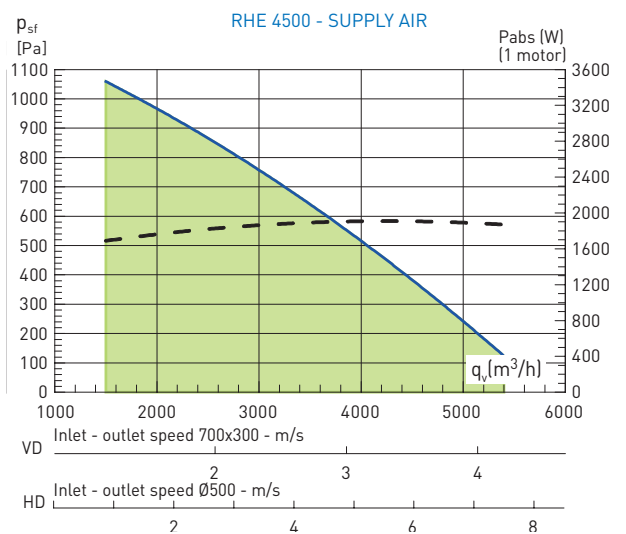
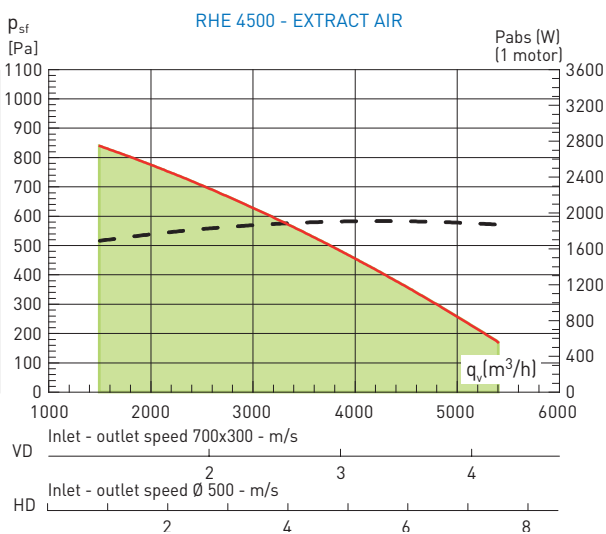
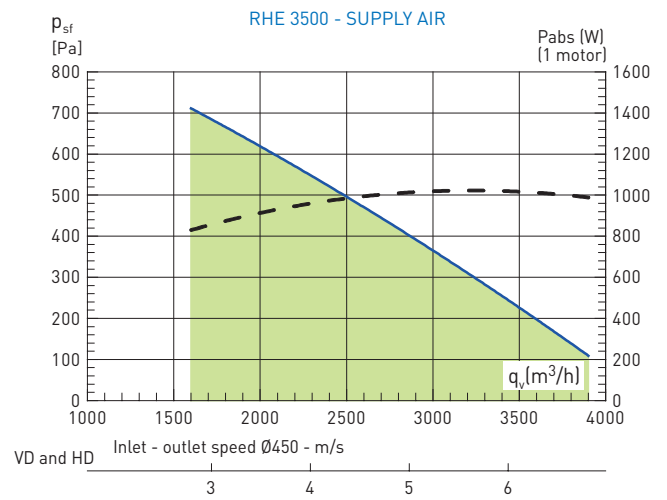
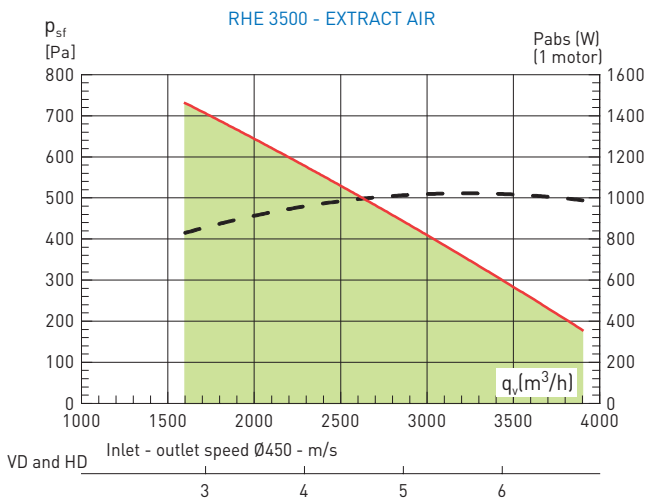
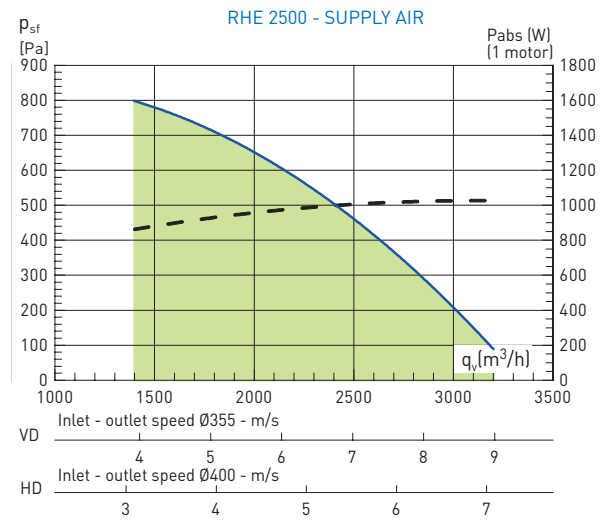
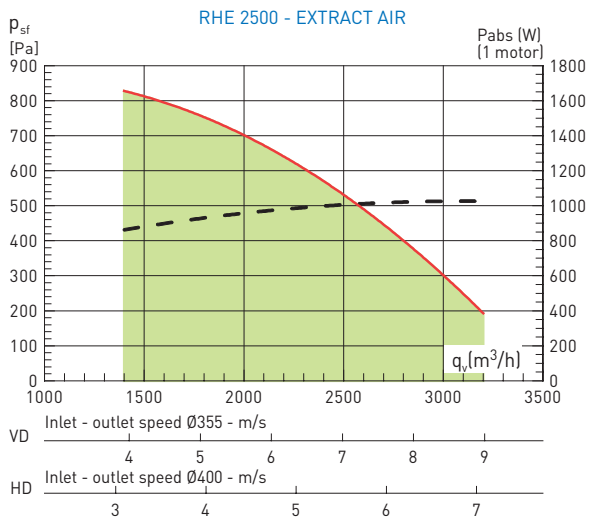

PERFORMANCE CURVE

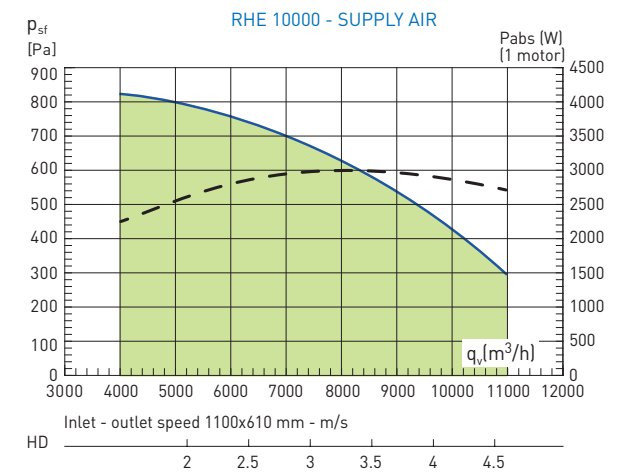
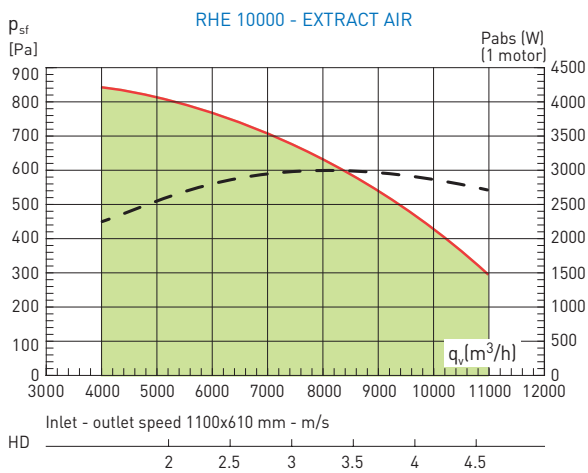
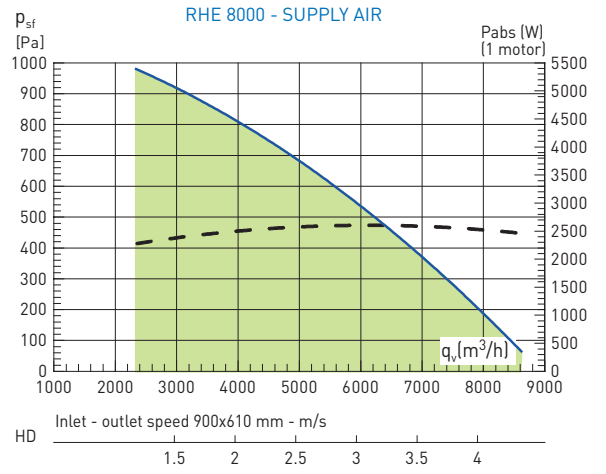
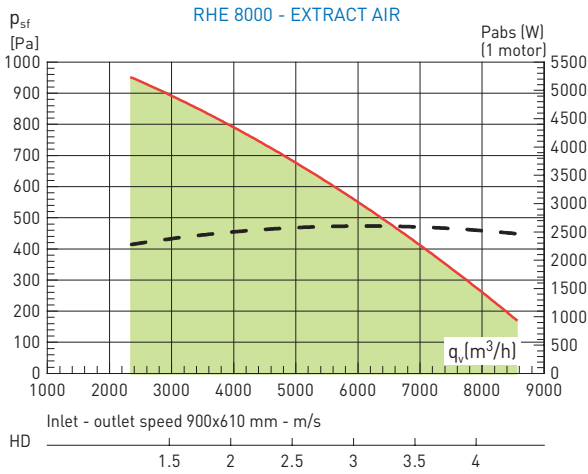
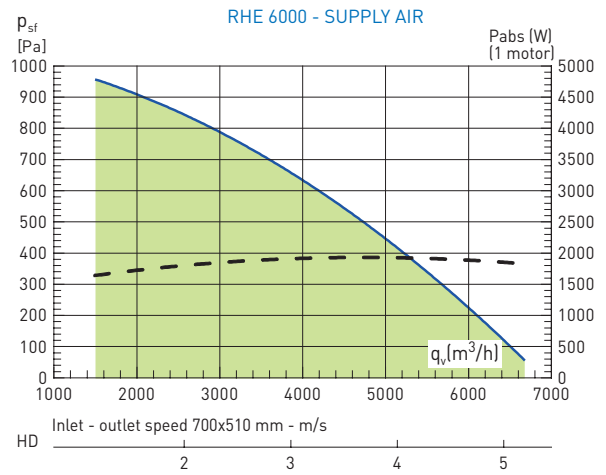
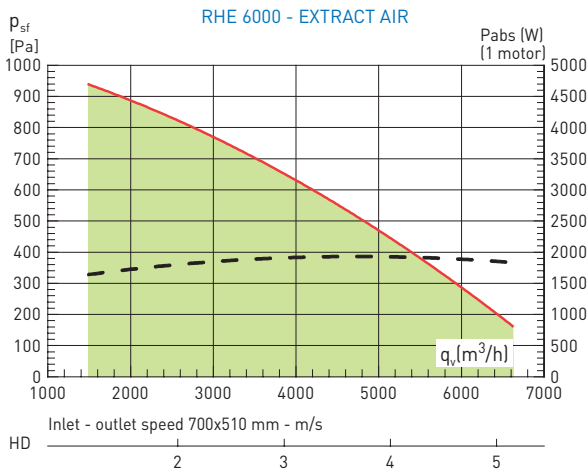

PERFORMANCE CURVE

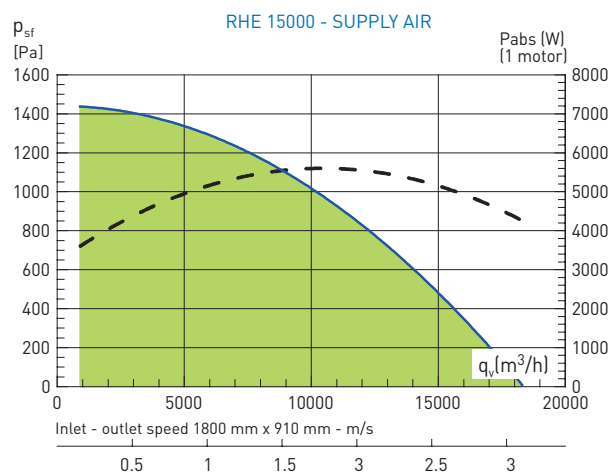
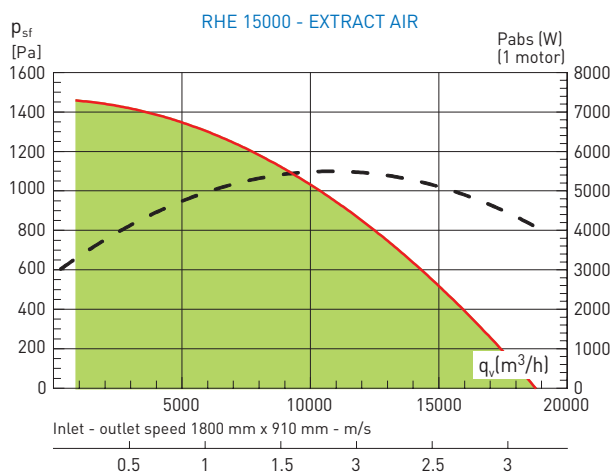

HIGH EFFICIENCY HEAT RECOVERY UNITS WITH ROTARY WHEEL

RHE Series



THERMAL CHARACTERISTICS

RHE 700								
Airflow (m³/h)	WINTER Outdoor air -5°C HR 80% Extract air 20°C HR 50%				SUMMER Outdoor air 35°C HR 50% Extract air 25°C HR 45%			
	Temperature efficiency (sensible heat) (%)	T° supply air	% RH supply air	Sensible heat recovery (kW)	Temperature efficiency (sensible heat) (%)	T° supply air	% RH supply air	Sensible heat recovery (kW)
300	84	16	41	2,8	84	27	81	0,9
400	84	16	41	3,7	84	27	81	1,1
500	85	16	41	4,7	85	27	81	1,4
600	84	16	41	5,6	84	27	81	1,7
700	83	16	42	6,5	84	27	81	2

RHE 700 SO (SORPTION)												
Airflow (m³/h)	WINTER Outdoor air -5°C HR 80% Extract air 20°C HR 50%					SUMMER Outdoor air 35°C HR 50% Extract air 25°C HR 45%						
	Temperature efficiency (sensible heat) (%)	T° supply air	% RH supply air	Sensible + latent heat recovery (kW)	Temperature efficiency (sensible heat) (%)	T° supply air	% RH supply air	Sensible + latent heat recovery (kW)	Temperature efficiency (sensible heat) (%)	T° supply air	% RH supply air	Sensible + latent heat recovery (kW)
300	84	16	59	3,3	84	27	46	2,8	84	27	46	3,8
400	84	16	58	4,4	84	27	46	3,8	84	27	46	4,7
500	85	16	58	5,5	84	27	46	4,7	84	27	46	5,6
600	84	16	58	6,6	84	27	46	5,6	84	27	46	6,5
700	83	16	59	7,6	84	27	46	6,5	84	27	46	7,4

RHE 1300								
Airflow (m³/h)	WINTER Outdoor air -5°C RH 80% Extract air 20°C RH 50%				SUMMER Outdoor air 35°C RH 50% Extract air 26°C RH 50%			
	Temperature efficiency (sensible heat) (%)	T° supply air	% RH supply air	Sensible heat recovery (kW)	Temperature efficiency (sensible heat) (%)	T° supply air	% RH supply air	Sensible heat recovery (kW)
500	85	16	41	4,7	85	27	81	1,4
700	83	16	42	6,5	84	27	81	2
900	81	15	44	8,2	81	27	79	2,5
1000	80	15	42	8,7	80	27	79	2,7
1100	78	14	44	9,5	78	27	78	2,9
1200	76	14	45	10,1	76	27	77	3,1
1300	74	14	46	10,8	74	28	76	3,3

RHE 1300 SO (SORPTION)												
Airflow (m³/h)	WINTER Outdoor air -5°C RH 80% Extract air 20°C RH 50%					SUMMER Outdoor air 35°C RH 50% Extract air 25°C RH 45%						
	Temperature efficiency (sensible heat) (%)	T° supply air	% RH supply air	Sensible + latent heat recovery (kW)	Temperature efficiency (sensible heat) (%)	T° supply air	% RH supply air	Sensible + latent heat recovery (kW)	Temperature efficiency (sensible heat) (%)	T° supply air	% RH supply air	Sensible + latent heat recovery (kW)
500	85	16	58	5,5	85	27	46	4,7	85	27	46	5,6
700	83	16	59	7,6	84	27	46	6,5	84	27	46	7,4
900	81	15	60	9,5	81	27	46	8,1	81	27	46	9,0
1000	80	15	61	10,4	80	27	47	8,9	80	27	47	9,8
1100	78	14	61	11,1	78	27	47	9,5	78	27	47	10,4
1200	76	14	62	11,9	76	27	47	10,2	76	27	47	10,9
1300	74	14	63	12,6	74	28	47	10,8	74	28	47	11,5

RHE 1900								
Airflow (m³/h)	WINTER Outdoor air -5°C RH 80% Extract air 20°C RH 50%				SUMMER Outdoor air 35°C RH 50% Extract air 25°C RH 45%			
	Temperature efficiency (sensible heat) (%)	T° supply air	% RH supply air	Sensible heat recovery (kW)	Temperature efficiency (sensible heat) (%)	T° supply air	% RH supply air	Sensible heat recovery (kW)
500	84	16	42	4,7	84	27	81	1,4
750	84	16	41	7	84	27	81	2,2
1000	84	16	42	9,3	84	27	81	2,8
1250	82	15	43	11,4	82	27	80	3,5
1500	79	15	43	13	79	27	79	4
1750	76	14	45	14,8	76	27	77	4,5
1900	74	14	46	15,7	74	28	76	4,8

RHE 1900 SO (SORPTION)												
Airflow (m³/h)	WINTER Outdoor air -5°C RH 80% Extract air 20°C RH 50%					SUMMER Outdoor air 35°C RH 50% Extract air 25°C RH 45%						
	Temperature efficiency (sensible heat) (%)	T° supply air	% RH supply air	Sensible + latent heat recovery (kW)	Temperature efficiency (sensible heat) (%)	T° supply air	% RH supply air	Sensible + latent heat recovery (kW)	Temperature efficiency (sensible heat) (%)	T° supply air	% RH supply air	Sensible + latent heat recovery (kW)
500	84	16	58	5,5	84	27	46	4,7	84	27	46	5,6
750	84	16	58	8,2	84	27	46	7	84	27	46	7,9
1000	84	16	59	10,9	84	27	46	9,3	84	27	46	10,2
1250	82	15	60	13,3	82	27	46	11,4	82	27	46	12,3
1500	79	15	61	15,4	79	27	47	13,2	79	27	47	14,1
1750	76	14	62	17,3	76	27	47	14,8	76	27	47	16,7
1900	74	14	63	18,3	74	28	47	15,7	74	28	47	17,6

RHE 2500								
Airflow (m³/h)	WINTER Outdoor air -5°C RH 80% Extract air 20°C RH 50%				SUMMER Outdoor air 35°C RH 50% Extract air 25°C RH 45%			
	Temperature efficiency (sensible heat) (%)	T° supply air	% RH supply air	Sensible heat recovery (kW)	Temperature efficiency (sensible heat) (%)	T° supply air	% RH supply air	Sensible heat recovery (kW)
1400	84	16	42	13	84	27	81	4
1600	83	16	42	14,8	83	27	80	4,5
1800	82	16	43	16,5	82	27	80	5
2000	81	15	44	18,1	81	27	79	5,5
2200	80	15	42	19,2	80	27	79	6
2400	78	15	43	20,7	78	27	78	6,4
2600	77	14	45	22	77	27	77	6,8

RHE 2500 SO (SORPTION)												
Airflow (m³/h)	WINTER Outdoor air -5°C RH 80% Extract air 20°C RH 50%					SUMMER Outdoor air 35°C RH 50% Extract air 25°C RH 45%						
	Temperature efficiency (sensible heat) (%)	T° supply air	% RH supply air	Sensible + latent heat recovery (kW)	Temperature efficiency (sensible heat) (%)	T° supply air	% RH supply air	Sensible + latent heat recovery (kW)	Temperature efficiency (sensible heat) (%)	T° supply air	% RH supply air	Sensible + latent heat recovery (kW)
1400	84	16	59	15,3	84	27	46	13,1	84	27	46	14,0
1600	83	16	59	17,3	83	27	46	14,8	83	27	46	15,7
1800	82	16	59	19,3	82	27	46	16,5	82	27	46	17,4
2000	81	15	60	21,1	81	27	46	18	81	27	46	19,7
2200	80	15	61	22,8	80	27	47	19,5	80	27	47	21,2
2400	78	15	61	24,4	78	27	47	20,9	78	27	47	22,4
2600	77	14	62	25,9	77	27	47	22,1	77	27	47	23,3

RHE 3.500								
Airflow (m³/h)	WINTER Outdoor air -5°C RH 80% Extract air 20°C RH 50%				SUMMER Outdoor air 35°C RH 50% Extract air 25°C RH 45%			
	Temperature efficiency (sensible heat) (%)	T° supply air	% RH supply air	Sensible heat recovery (kW)	Temperature efficiency (sensible heat) (%)	T° supply air	% RH supply air	Sensible heat recovery (kW)
1600	85	16	41	15	85	27	81	4,6
1900	84	16	42	17,7	84	27	81	5,4
2200	83	16	42	20,4	83	27	81	6,2
2500	82	16	43	23	82	27	80	7
2800	81	15	44	25,4	81	27	79	7,7
3100	80	15	42	27,1	80	27	79	8,4
3500	78	14	44	29,9	78	27	78	9,2

RHE 3500 SO (SORPTION)												
Airflow (m³/h)	WINTER Outdoor air -5°C RH 80% Extract air 20°C RH 50%					SUMMER Outdoor air 35°C RH 50% Extract air 25°C RH 45%						
	Temperature efficiency (sensible heat) (%)	T° supply air	% RH supply air	Sensible + latent heat recovery (kW)	Temperature efficiency (sensible heat) (%)	T° supply air	% RH supply air	Sensible + latent heat recovery (kW)	Temperature efficiency (sensible heat) (%)	T° supply air	% RH supply air	Sensible + latent heat recovery (kW)
1600	85	16	58	17,6	85	27	46	15	85	27	46	16,5
1900	84	16	58	20,8	84	27	46	17,8	84	27	46	18,7
2200	83	16	59	23,9	83	27	46	20,4	83	27	46	21,3
2500	82	16	59	26,8	82	27	46	22,9	82	27	46	24,8
2800	81	15	60	29,5	81	27	46	25,3	81	27	46	27,2
3100	80	15	61	32,1	80	27	47	27,5	80	27	47	29,6
3500	78	14	62	35,2	78	27	47	30,2	78	27	47	32,6

HIGH EFFICIENCY HEAT RECOVERY UNITS WITH ROTARY WHEEL

RHE Series



THERMAL CHARACTERISTICS

RHE 4500								
Airflow (m³/h)	WINTER Outdoor air -5°C RH 80% Extract air 20°C HR 50%				SUMMER Outdoor air 35°C RH 50% Extract air 25°C HR 45%			
	Temperature efficiency (sensible heat) (%)	T° supply air	% RH supply air	Sensible heat recovery (kW)	Temperature efficiency (sensible heat) (%)	T° supply air	% RH supply air	Sensible heat recovery (kW)
	2000	84	16	42	18,6	84	27	81
2500	82	16	43	23	82	27	80	7
3000	80	15	42	26,4	80	27	79	8,2
3500	78	14	44	29,9	78	27	78	9,2
4000	75	14	46	33,3	75	28	76	10,2
4500	72	13	45	35,4	72	28	75	11

RHE 4500 SO (SORPTION)								
Airflow (m³/h)	WINTER Outdoor air -5°C RH 80% Extract air 20°C HR 50%				SUMMER Outdoor air 35°C RH 50% Extract air 25°C HR 45%			
	Temperature efficiency (sensible heat) (%)	T° supply air	% RH supply air	Sensible heat recovery (kW)	Temperature efficiency (sensible heat) (%)	T° supply air	% RH supply air	Sensible heat recovery (kW)
	2000	84	16	58	21,9	84	27	46
2500	82	16	59	26,8	82	27	46	22,9
3000	80	15	60	31,3	80	27	47	26,7
3500	78	14	62	35,2	78	27	47	30,2
4000	75	14	63	38,8	75	28	47	33,2
4500	72	13	64	42	72	28	50	36

RHE 6000								
Airflow (m³/h)	WINTER Outdoor air -5°C RH 80% Extract air 20°C RH 50%				SUMMER Outdoor air 35°C RH 50% Extract air 25°C RH 45%			
	Temperature efficiency (sensible heat) (%)	T° supply air	% RH supply air	Sensible heat recovery (kW)	Temperature efficiency (sensible heat) (%)	T° supply air	% RH supply air	Sensible heat recovery (kW)
	2000	88	17	40	19,6	88	26	83
2750	87	17	41	26,7	87	26	82	8,2
3500	85	16	42	33,5	85	26	82	10,2
4250	83	16	41	38,8	83	27	80	12
5000	80	15	43	44,4	80	27	79	13,6
5500	78	14	45	47,8	78	27	78	14,5
6000	76	14	44	49,7	76	27	77	15,4

RHE 6000 SO (SORPTION)								
Airflow (m³/h)	WINTER Outdoor air -5°C RH 80% Extract air 20°C RH 50%				SUMMER Outdoor air 35°C RH 50% Extract air 25°C RH 45%			
	Temperature efficiency (sensible heat) (%)	T° supply air	% RH supply air	Sensible + latent heat recovery (kW)	Temperature efficiency (sensible heat) (%)	T° supply air	% RH supply air	Sensible + latent heat recovery (kW)
	2000	88	17	57	22,9	88	26	45
2750	87	17	57	31,3	87	26	46	26,7
3500	85	16	58	39	85	26	46	33,2
4250	83	16	59	45,9	83	27	46	39,1
5000	80	15	60	52	80	27	47	44,4
5500	78	14	61	55,6	78	27	47	47,5
6000	76	14	62	59	76	27	47	50,4

RHE 8000								
Airflow (m³/h)	WINTER Outdoor air -5°C RH 80% Extract air 20°C RH 50%				SUMMER Outdoor air 35°C RH 50% Extract air 25°C RH 45%			
	Temperature efficiency (sensible heat) (%)	T° supply air	% RH supply air	Sensible heat recovery (kW)	Temperature efficiency (sensible heat) (%)	T° supply air	% RH supply air	Sensible heat recovery (kW)
	2500	88	17	40	24,4	88	26	83
3000	88	17	40	29,3	88	26	83	9
4000	87	17	41	38,9	87	26	82	11,9
5000	86	16	42	47,9	86	26	82	14,6
6000	83	16	43	56,3	83	27	80	17
7000	81	15	43	62,5	81	27	79	19,2
8000	78	14	45	69,5	78	27	78	21,1

RHE 8000 SO (SORPTION)								
Airflow (m³/h)	WINTER Outdoor air -5°C RH 80% Extract air 20°C RH 50%				SUMMER Outdoor air 35°C RH 50% Extract air 25°C RH 45%			
	Temperature efficiency (sensible heat) (%)	T° supply air	% RH supply air	Sensible + latent heat recovery (kW)	Temperature efficiency (sensible heat) (%)	T° supply air	% RH supply air	Sensible + latent heat recovery (kW)
	2500	88	17	57	28,6	88	26	45
3000	88	17	57	34,4	88	26	45	29,3
4000	87	17	57	45,6	87	26	46	38,8
5000	86	16	58	55,7	86	26	46	48
6000	83	16	59	65,1	83	27	46	55,5
7000	81	15	60	73,4	81	27	47	62,7
8000	78	14	61	80,8	78	27	47	69

RHE 10000								
Airflow (m³/h)	WINTER Outdoor air -5°C RH 80% Extract air 20°C RH 50%				SUMMER Outdoor air 35°C RH 50% Extract air 25°C RH 45%			
	Temperature efficiency (sensible heat) (%)	T° supply air	% RH supply air	Sensible heat recovery (kW)	Temperature efficiency (sensible heat) (%)	T° supply air	% RH supply air	Sensible heat recovery (kW)
	4000	88	17	40	39,1	88	26	83
5000	87	17	41	48,6	87	26	82	14,8
6000	86	17	41	57,7	86	26	82	17,6
7000	85	16	43	66,4	85	27	81	20,1
8000	83	16	42	72,8	83	27	80	22,4
9000	80	15	43	80,2	80	27	79	24,6
10000	78	15	45	87,1	78	27	78	26,5

RHE 10000 SO (SORPTION)								
Airflow (m³/h)	WINTER Outdoor air -5°C RH 80% Extract air 20°C RH 50%				SUMMER Outdoor air 35°C RH 50% Extract air 25°C RH 45%			
	Temperature efficiency (sensible heat) (%)	T° supply air	% RH supply air	Sensible + latent heat recovery (kW)	Temperature efficiency (sensible heat) (%)	T° supply air	% RH supply air	Sensible + latent heat recovery (kW)
	4000	88	17	57	45,8	88	26	45
5000	87	17	57	56,9	87	26	46	48,5
6000	86	17	58	67,3	86	26	46	57,4
7000	85	16	58	77	85	27	46	65,7
8000	83	16	59	85,9	83	27	46	73,4
9000	80	15	60	94,1	80	27	47	80,3
10000	78	15	61	101,5	78	27	47	86,7

RHE 15000								
Airflow (m³/h)	WINTER Outdoor air -5°C RH 80% Extract air 20°C RH 50%				SUMMER Outdoor air 35°C RH 50% Extract air 25°C RH 45%			
	Temperature efficiency (sensible heat) (%)	T° supply air	% RH supply air	Sensible heat recovery (kW)	Temperature efficiency (sensible heat) (%)	T° supply air	% RH supply air	Sensible heat recovery (kW)
	9000	84	16	39	81,8	84	27	77
10000	83	16	40	90,0	83	28	76	25,0
11000	82	15	41	98,1	82	28	76	27,6
12000	81	15	41	105,9	81	28	76	29,7
13000	80	15	42	113,5	80	28	75	31,7
14000	79	15	40	117,2	79	28	75	33,7
15000	77	14	40	124,1	77	28	74	35,5

RHE 15000 SO (SORPTION)								
Airflow (m³/h)	WINTER Outdoor air -5°C RH 80% Extract air 20°C RH 50%				SUMMER Outdoor air 35°C RH 50% Extract air 25°C RH 45%			
	Temperature efficiency (sensible heat) (%)	T° supply air	% RH supply air	Sensible + latent heat recovery (kW)	Temperature efficiency (sensible heat) (%)	T° supply air	% RH supply air	Sensible + latent heat recovery (kW)
	9000	84	16	52	92,7	83	28	55
10000	83	16	52	101,7	82	28	55	66,8
11000	82	16	51	110,3	81	28	56	71,6
12000	82	16	50	118,5	81	28	56	76,0
13000	81	15	50	126,1	79	28	57	80,0
14000	81	15	50	133,3	78	28	57	83,6
15000	80	15	49	140,0	77	28	57	86,7

MIB MIXING MODULES (ACCESSORY)

Mixing modules are mainly used in installations that combine ventilation with heating and/or air-conditioning to further optimise the energy savings of the installation.

Versions:

MIB L: Access from the left side, can be combined with the RHE HDL.

MIB R: Right-hand side access, can be combined with the RHE HDR. Wide hinged doors, allowing easy access to components. Robust construction consisting of a self-supporting housing with 50 mm sandwich panel (mineral wool, 40 kg/m³, thermal conductivity 0.037 W/mK).

Outer plate painted in RAL7024, highly resistant to corrosion (class: RC3) and UV rays (class: RUV3) according to EN 10169 standard with the inner face in galvanized steel.

Circular connections with VELODUCT® class D sealing gaskets up to model 4500, rectangular connections for models 6000, 8000, 10000 and 15000.

All modules are equipped with servomotors and a 230V/24V transformer.

Types:

MIB ON-OFF

Used when we need to recirculate the exhaust air 100% for a programmed time to heat/cool the air.

The module works through time programming, which is carried out with the integrated control in the RHE once connected. Timing must be carried out on channel 5 of the timer.

The module has 3 dampers with all-in-one servomotors mounted. There are two servo motor options, the standard and the SR which has a return spring which ensures that in the event of power failure the dampers are closed.

MIB 0-10V

Used when we need to recirculate the exhaust air for a programmed time in order to heat/cool the air proportionally depending on the CO₂.

The module is equipped with a CO₂ sensor in the air outlet and 3 dampers with proportional servomotors mounted. The CO₂ sensor (range between 400 and 1100 ppm) permanently measures the CO₂ level of the exhaust air. A proportional signal is sent to the dampers to open/close them according to air quality.

There are two servo motor options: the standard proportional (0-10V) and the proportional SR which has a return spring that ensures the closing of the dampers in case of power cut-off.



HIGH EFFICIENCY HEAT RECOVERY UNITS WITH ROTARY WHEEL

RHE Series



Dimensions 07 to 45

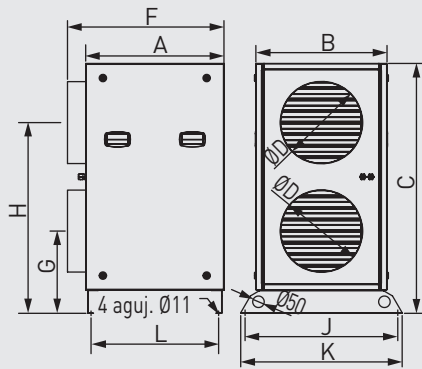

Model	A	B	C	D	F
MIB 700/1300	550	470	982,5	315	630
MIB 1900	600	581	1082,5	355	678
MIB 2500	650	700	1182,5	400	700
MIB 3500	750	860	1362,5	450	830
MIB 4500	750	860	1362,5	500	830

Model	G	H	J	K	L	Weight (kg)
MIB 700/1300	330	754	562	600	503	62
MIB 1900	356	826	662	700	553	67
MIB 2500	380	904	812	850	603	85
MIB 3500	426	1036	972	1010	703	119
MIB 4500	426	1036	972	1010	703	119

Dimensions 60 to 100

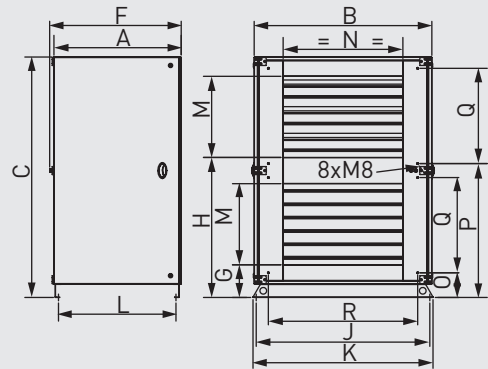

Model	A	B	C	F	G	H	J	K
MIB 6000	850	1082,5	1552,5	878,5	220	925	1052	1100
MIB 8000	954,5	1332,5	1802,5	981,5	245	1050	1302	1350
MIB 10000	950	1502,5	1972,5	981,5	287,5	1177,5	1472	1520

Model	L	M	N	O	P	Q	R	Weight (kg)
MIB 6000	781	510	700	185	899	569	870	163
MIB 8000	881	610	900	185	1004	714	1120	215
MIB 10000	881	610	1100	185	1175	714	1290	238

Dimensiones 150

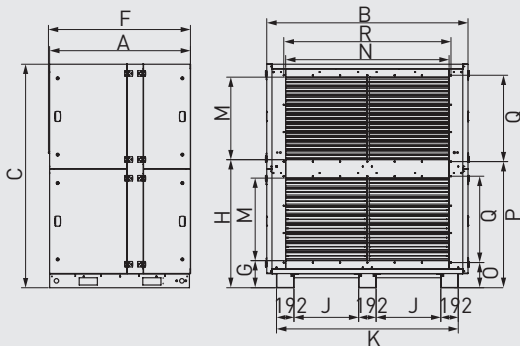

Model	A	B	C	F	G	H	J	K
MIB 15000	1549	2215	2460	1563	298	1409	712	2000

Model	L	M	N	O	P	Q	R	Weight (kg)
MIB 15000		908	1798	277	950	1388	1840	715/815*

*Out door installation (O) with roof.

HIGH EFFICIENCY HEAT RECOVERY UNITS WITH ROTARY WHEEL

RHE Series



ACCESSORIES

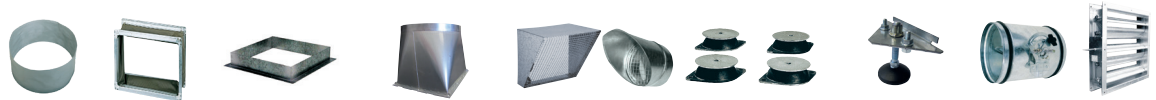

Model	Connection (mm)	Flexible connection	Rectangular flange	Rectangular-circular reduction	Rain cap	Antibrain feet (1 pack = 4 uds.) ^[1]	KIT adjustable feet (1 kit = 4 ó 6 uds.) ^[2]	Anti-freeze damper ^[3]
RHE 700 VD	Ø250	ACOPEL F400-250/160 N	-	-	-	PAVZ 80 SH 60	KIT 4 AF	REEV 250
RHE 1300 VD	Ø250	ACOPEL F400-250/160 N	-	-	-	PAVZ 80 SH 60	KIT 4 AF	REEV 250
RHE 1900 VD	Ø315	ACOPEL F400-315/160 N	-	-	-	PAVZ 80 SH 60	KIT 4 AF	REEV 315
RHE 2500 VD	Ø355	ACOPEL F400-355/160 N	-	-	-	PAVZ 100 SH 75	KIT 6 AF	REEV 355
RHE 3500 VD	Ø450	ACOPEL F400-450/160 N	-	-	-	PAVZ 100 SH 75	KIT 6 AF	REEV 450
RHE 4500 VD	Ø700x310	ACOPEL RECT 4500	BRL 700x310	-	-	PAVZ 100 SH 75	KIT 6 AF	MLD 4500 T
RHE 700 HD	Ø315	ACOPEL F400-315/160 N	-	-	APC-315	PAVZ 80 SH 60	KIT 4 AF	REEV 315
RHE 1300 HD	Ø315	ACOPEL F400-315/160 N	-	-	APC-315	PAVZ 80 SH 60	KIT 4 AF	REEV 315
RHE 1900 HD	Ø355	ACOPEL F400-355/160 N	-	-	APC-355	PAVZ 80 SH 60	KIT 4 AF	REEV 355
RHE 2500 HD	Ø400	ACOPEL F400-400/160 N	-	-	APC-400	PAVZ 80 SH 60	KIT 6 AF	REEV 400
RHE 3500 HD	Ø450	ACOPEL F400-450/160 N	-	-	APC-450	PAVZ 100 SH 75	KIT 6 AF	REEV 450
RHE 4500 HD	Ø500	ACOPEL F400-500/160 N	-	-	APC-500	PAVZ 100 SH 75	KIT 6 AF	REEV 500
RHE 6000 HD	Ø700x510	ACOPEL RECT 6000	BRL 700x510	PRRE 700x510/630	APPR-6000 APPA-6000	PAVZ 100 SH 75	KIT 4 AF	MLD 6000 T
RHE 8000 HD	Ø900x610	ACOPEL RECT 8000	BRL 900x610	PRRE 900x610/800	APPR-8000 APPA-8000	PAVZ 100 SH 75	KIT 4 AF	MLD 8000 T
RHE 10000 HD	Ø1100x610	ACOPEL RECT 10000	BRL 1100x610	PRRE 1100x610/900	APPR-10000 APPA-10000	PAVZ 100 SH 75	KIT 4 AF	MLD 10000 T
RHE 15000 HD	Ø1800x910	ACOPEL RECT 15000	BRL 1800x910	-	APPR-15000 APPA-15000	PAVZ 100 SH 75	KIT 4 AF	MLD 15000 T

^[1] RHE 3500, 4500, 6000, 8000 and 10000 models is necessary to use 2 packs PAVZ 100 SH 75. RHE 15000 model is necessary to use 3 packs.

^[2] RHE 6000, 8000 and 10000 models is necessary to use 2 kits 4 AF. RHE 15000 model is necessary to use 3 kits.

^[3] To obtain a motorized damper must be mounted a servomotor LF-230S, LF 24 S (electrical accessories).

ACCESSORIES-FILTERS

Type of filters provided with the product

	Prefilter		Filter	
	G4 (Grossier 60%)	M5 (ePM10 75%)	F7 (ePM1 55%)	F9 (ePM1 80%)
Extract air	-	✓	✓	-
Supply air	✓	*	-	*

*Available as a replacement alternative.



Model	Filters				Quantity to order
	AFR RHE G4 (Grossier 60%)	AFR RHE M5 (ePM10 75%)	AFR RHE F7 (ePM1 55%)	AFR RHE F9 (ePM1 80%)	
RHE 700	AFR RHE 700/1300 G4	AFR RHE 700/1300 M5	AFR RHE700/1300 F7	AFR RHE 700/1300 F9	1
RHE 1300	AFR RHE 700/1300 G4	AFR RHE 700/1300 M5	AFR RHE700/1300 F7	AFR RHE 700/1300 F9	1
RHE 1900	AFR RHE 1900 G4	AFR RHE 1900 M5	AFR RHE 1900 F7	AFR RHE 1900 F9	1
RHE 2500	AFR RHE 2500 G4	AFR RHE 2500 M5	AFR RHE 2500 F7	AFR RHE 2500 F9	2
RHE 3500	AFR RHE 3500/4500 G4	AFR RHE 3500/4500 M5	AFR RHE 3500/4500 F7	AFR RHE 3500/4500 F9	2
RHE 4500	AFR RHE 3500/4500 G4	AFR RHE 3500/4500 M5	AFR RHE 3500/4500 F7	AFR RHE 3500/4500 F9	2
RHE 6000	AFR RHE 6000 G4	AFR RHE 6000 M5	AFR RHE 6000 F7	AFR RHE 6000 F9	2
RHE 8000	AFR RHE 8000 G4	AFR RHE 8000 M5	AFR RHE 8000 F7	AFR RHE 8000 F9	3
RHE 10000	AFR RHE 10000 G4	AFR RHE 10000 M5	AFR RHE 10000 F7	AFR RHE 10000 F9	4
RHE 15000	AFR RHE 15000 G4	AFR RHE 15000 M5	AFR RHE 15000 F7	AFR RHE 15000 F9	8

ACCESSORIES



MLD
Anti-freeze damper.

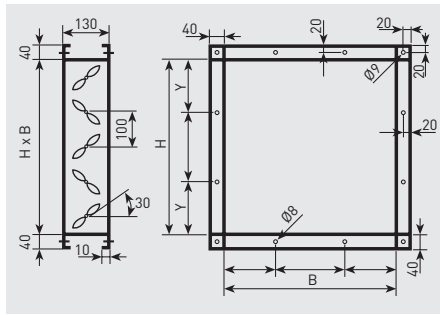

Model	B	H
MLD 4500 T	700	310
MLD 6000 T	700	510
MLD 8000 T	900	610
MLD 10000 T	1100	610
MLD 15000 T	1800	910



ACOPEL RECT
Rectangular elastic coupling.

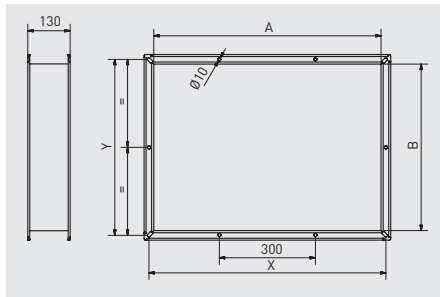

Model	A	B	X	Y
ACOPEL RECT 4500	710	320	740	350
ACOPEL RECT 6000	710	520	740	550
ACOPEL RECT 8000	910	620	940	650
ACOPEL RECT 10000	1110	620	1140	650
ACOPEL RECT 15000	1810	910	1840	325

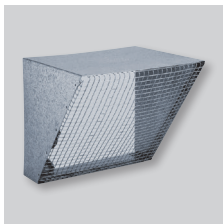

APPR/APPA
Protection guard for exhaust air / outdoor air.

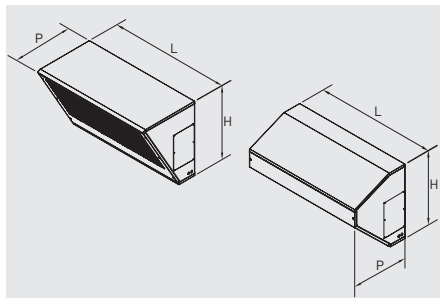

Model	Description	H	L	P
APPR 6000	Exhaust air	647	1062	522
APPR 8000	Exhaust air	747	1262	580
APPR 10000	Exhaust air	747	1465	564
APPR 15000	Exhaust air	1091	2100*	702
APPA 6000	Outdoor air	647	1062	506
APPA 8000	Outdoor air	747	1262	564
APPA 10000	Outdoor air	747	1465	564
APPA 15000	Outdoor air	1091	2100*	702

* Delivered in 2 parts of 1050 mm each.

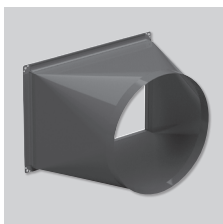

PRRE
Reductions circular rectangles.

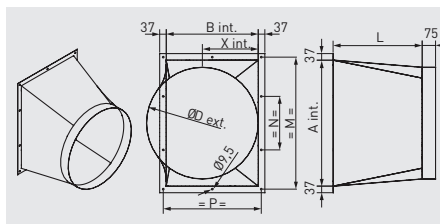

Model	A	B	ØD	L	M	N	P	X
PRRE 700x510 D630	706	516	627	500	740	300	550	315
PRRE 900x610 D800	906	616	797	600	940	300	650	400
PRRE 1100x610 D900	1106	616	897	700	1140	300	650	450



SPRD B
Pressure sensor. Specially adapted for the range RHE when constant pressure (COP) control is required.

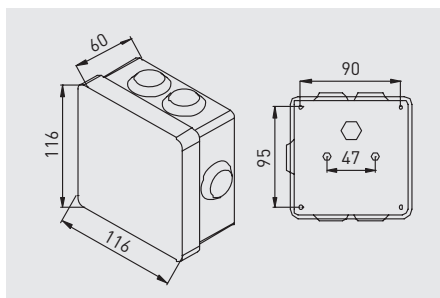

Model	Electrical supply	Maximum power (W)	Output	IP Protection	Pressure range
SPRDB	12-24Vdc	8mA	0,5-4,5Vdc	Box IP54	0-800Pa

ACCESSORIES

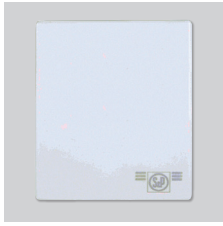

SC02-A 0/10 V
Ambient CO₂ and
temperature sensor.



SC02-G 0/10 V
CO₂ sensor for the
duct.



KTPR
Kit of 2 pressure
taps + screws + 2 m
Translucid tube.



LF 230 S
(AC 230V, 50/60Hz)

LF 24 S
(AC 24V 50/60Hz/
DC 24V)
Actuator with spring
return motor. 4 Nm.
Control signal
On/Off.



**3-WAY VALVES WITH
PROPORTIONAL
ACTUATOR**
Three way motorised
control valve.