



DOMEO 210 FL 3V EU



CONTENTS

1. GENERAL INFORMATION 4

2. TECHNICAL INFORMATION 4

3. INSTALLATION 7

4. CHARACTERISTICS AND ELECTRICAL CONNECTIONS 9

5. COMMISSIONING OF THE DOMEO 12

6. REMOTE CONTROL ADJUSTMENTS - USER 14

7. SWITCHING ON THE DOMEO 15

8. ALARM INDEX 16

9. PRE-HEATER FOR PASSIVHOUSE APPLICATION 17

10. PUTTING OUT OF SERVICE AND RECYCLING 17

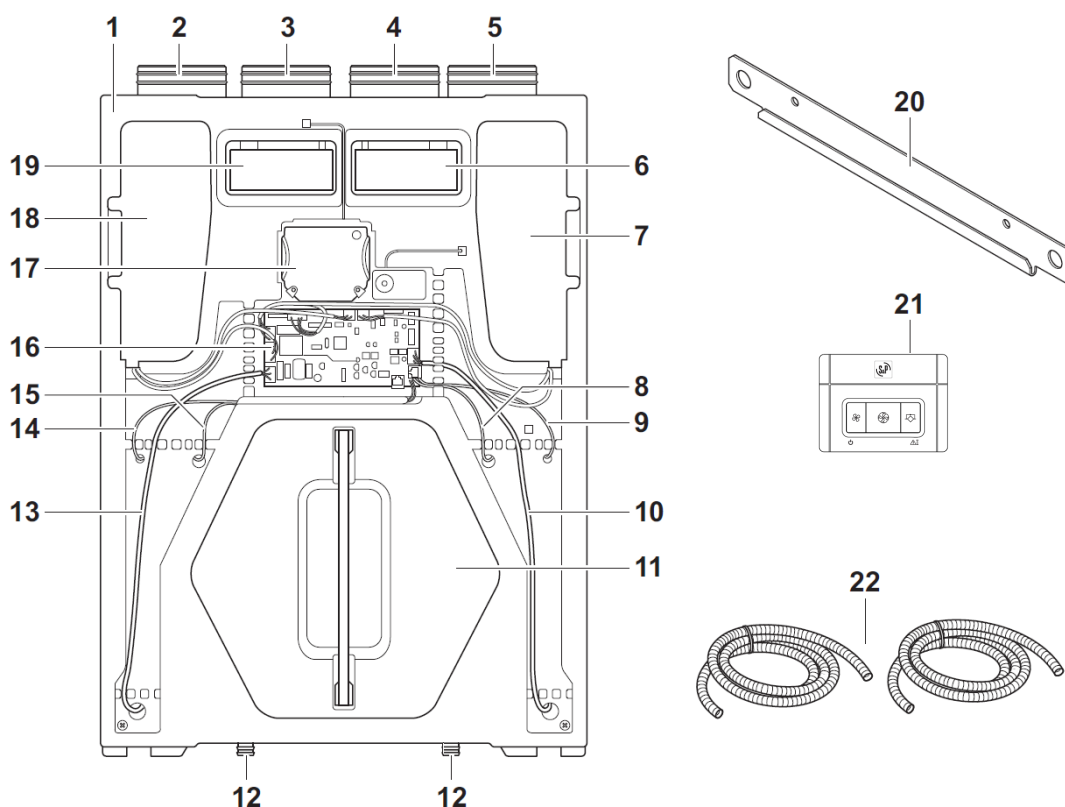

- | | | | |
|----|-------------------------------------|----|-------------------------------------|
| 1 | DOMEO 210 3V FL | 13 | Cable for power supply |
| 2 | Connection Supply Air | 14 | Temperature sensor supply air (T2) |
| 3 | Connection Extract Air | 15 | Temperature sensor extract air (T3) |
| 4 | Connection Outdoor Air | 16 | Electronic board |
| 5 | Connection Exhaust Air | 17 | Bypass |
| 6 | Filter F7 (Outdoor Air) | 18 | Supply fan |
| 7 | Extract fan | 19 | Filter G4 (Extract air) |
| 8 | Temperature sensor Outdoor Air (T1) | 20 | Wall bracket |
| 9 | Temperature sensor Exhaust Air (T4) | 21 | Remote control |
| 10 | Cable for remote Control | 22 | Drain ducts |
| 11 | Counterflow heat exchanger | | |
| 12 | Drain connection | | |



1. GENERAL INFORMATION

1.1. INTRODUCTION

This manual is intended for the use of the central balanced-flow high efficiency DOME0 and its peripherals (ductwork, vents, controllers).

It is designed to provide clear and safe guidance for the design, installation and use of the product.

The products are constantly evolving and so, Soler & Palau reserves the right to modify this manual without prior notice.

1.2. WARRANTY AND LIABILITY

Warranty

The DOME0 heat recovery system has three years warranty from the date of purchase. This warranty includes free delivery of necessary spare parts.

The warranty does not cover:

Installation and removal costs.

Defects that, in the opinion of Soler & Palau, are due to improper installation, handling, neglect or accidental damage.

Those defects that arise as a result from operations or repair performed by a third party without permission from Soler & Palau.

To return a defective part, the user should contact their installer.

Liability

DOME0 is designed for ventilation systems in individual dwellings.

Soler & Palau is not responsible for damage caused by:

- Improper use.
- Normal wear of components.
- Failure to follow the instructions in this manual concerning safety, use and installation.
- The use of parts not supplied by Soler & Palau.

1.3. SAFETY

General health and safety standards

The heat exchanger DOME0 has been designed to be incorporated into a ventilation system.

Following installation, there should be no risk to safety, health and the environment according to EC directives. This also applies to other products used in the installation.

The following general guidelines are important:

- Follow the safety instructions to prevent injuries and damage to the motorised fans.
- The technical characteristics described in this manual may not be changed.
- The motorised fans must not be modified.
- The motorised fans must be supplied with a single phase AC supply of 230 V / 50 Hz.
- So that the installation complies with EC directives, the DOME0 must be connected to the electricity grid according to current national standards.
- The device must be installed so that under normal operating conditions, there is no risk of contact with moving parts and power.
- The DOME0 meets legal requirements for electrical equipment.
- Before working on the machine, always turn the power off.
- Use appropriate tools.
- Use the machine only for the purpose for which it is intended.

2. TECHNICAL INFORMATION

2.1. GENERAL INFORMATION

The DOME0 ensures optimum ventilation of a house with a maximum energy recovery. It draws air from the rooms (bathroom(s), toilet, kitchen and wash room(s)) and supplies fresh air through the main rooms (living room, bedroom (s), office, etc).

The fresh and extract airflows are separated and filtered. Only heat energy is transferred to the fresh filtered air that is introduced.

Due to the high-efficiency heat exchanger used in the DOME0 performance can reach 95%.

Condensation forms during the heat exchange process and is recovered in the condensate tray, which must be connected to a waste water drain.

The DOME0 is equipped with a double condensate drain system that allows a proper working in winter (heating) and summer (cooling).

The DOME0 has a 100% heat exchanger bypass system and this allows the introduction of fresh air at night without it being heated by contact with warm air accumulated in the house during the day. The system operates automatically or can be used manually (see section 5-2).

2.2. DESCRIPTION

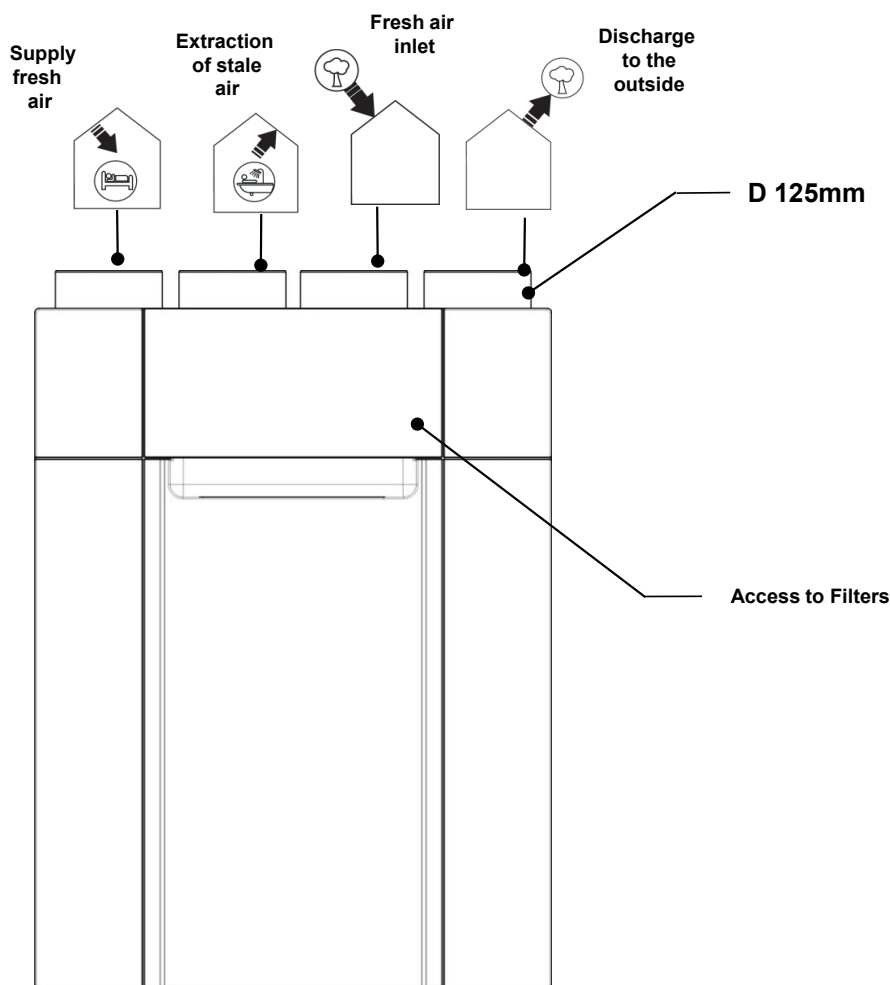

Outdoor air (ODA):

It is recommended to install the fresh air intake (wall or roof) at a sufficient distance from any area with high pollution (trees, exhaust fumes, road. etc.)



This duct must be sealed and insulated to prevent condensation.



Supply air (SUP):

To avoid thermal losses and optimize the performance of the installation, it is recommended to use insulated ducts.



Extract air (ETA):

To avoid thermal losses and optimize the performance of the installation, it is recommended to use insulated ducts.



Exhaust air (EHA):



This duct must be sealed and insulated to prevent condensation.



By-pass:

The DOME0 has a 100% heat exchanger bypass system which allows free cooling by night. The principle of free-cooling uses free energy from the outdoor air to ventilate and cool buildings when outdoor air temperature is lower than the exhaust air temperature.



2.3. DIMENSIONAL CHARACTERISTICS

2.3.a Heat recovery unit:

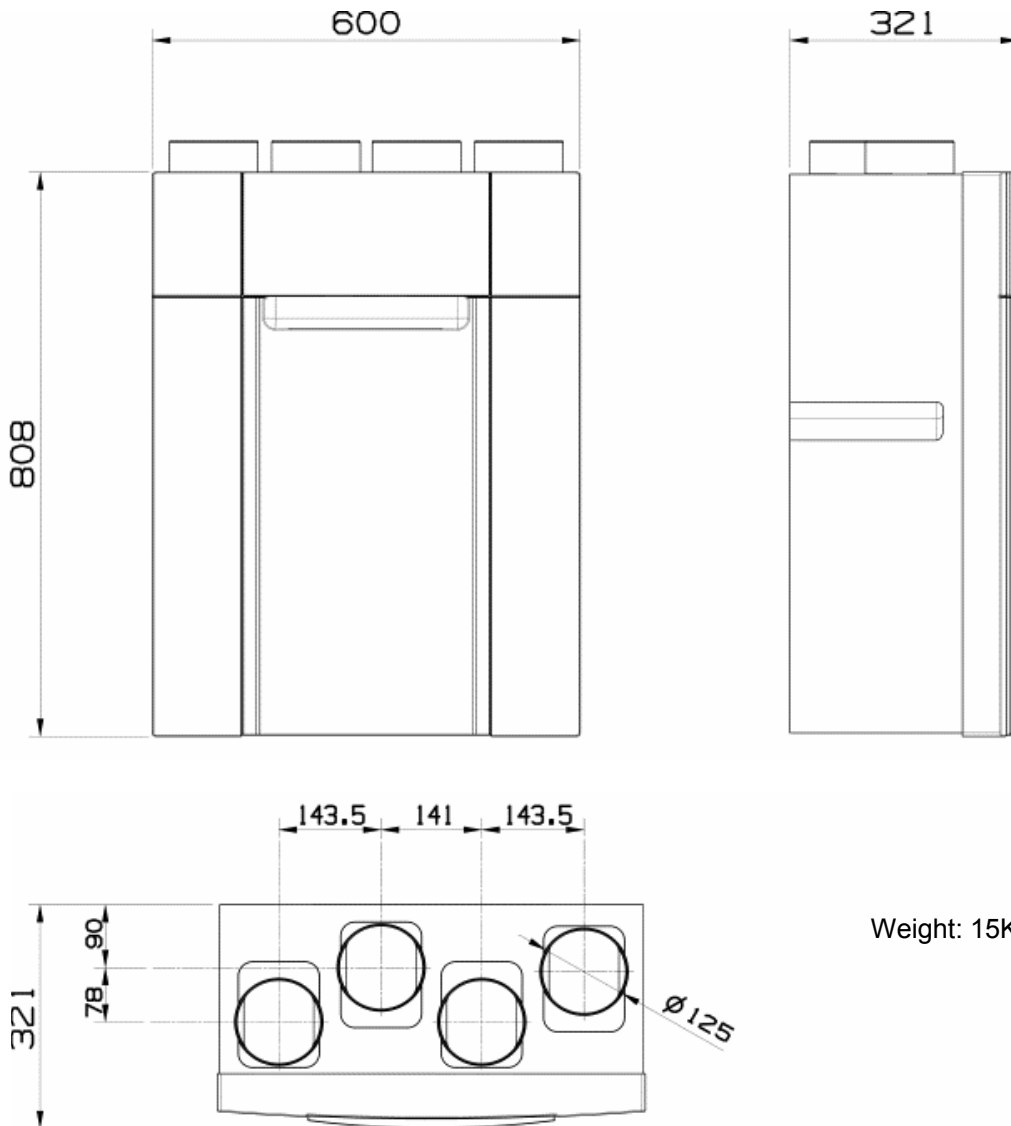

2.3.b Remote control:

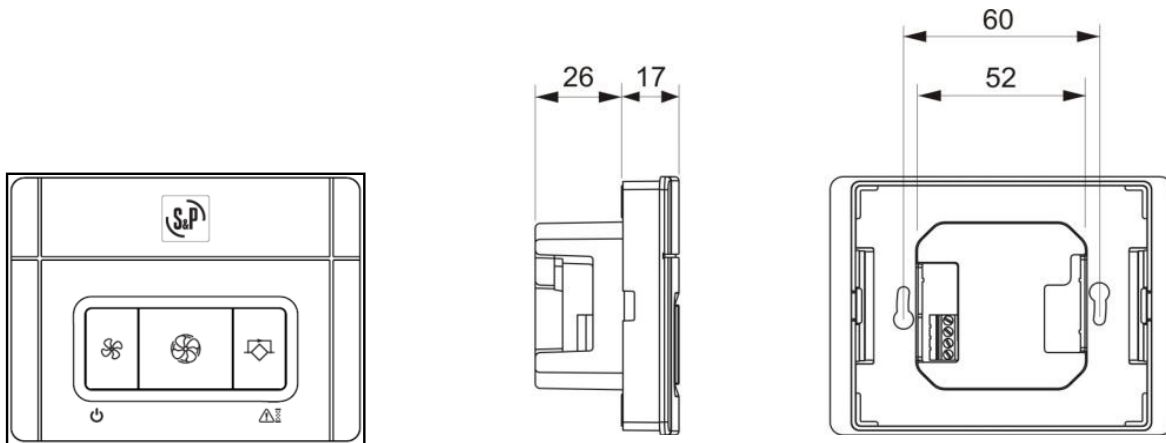

3. INSTALLATION

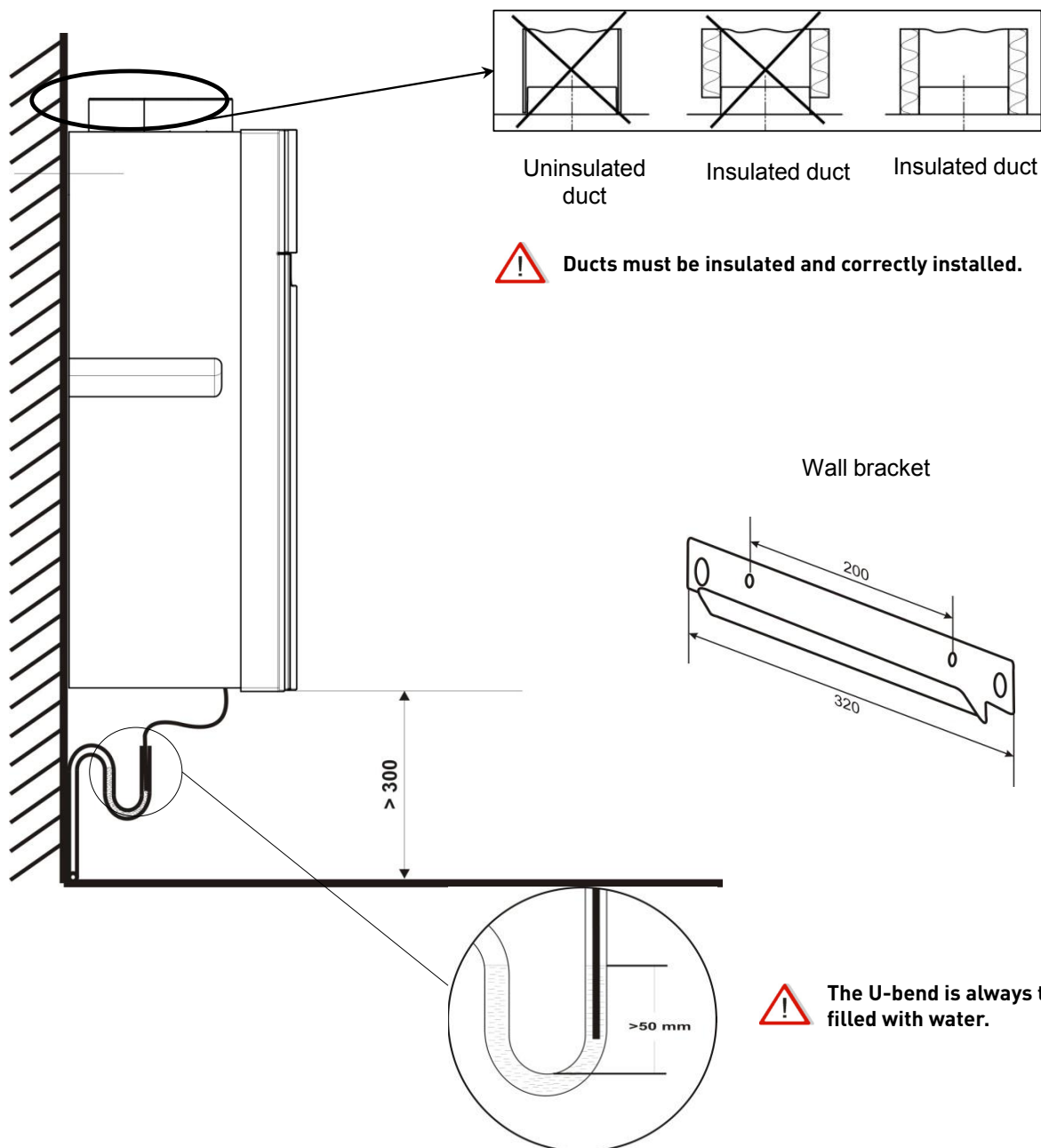

! The DOME0 heat recovery unit is designed for indoor installation. We recommend a min. temperature of +10°C in the room where the unit is installed to guarantee a good efficiency of the unit.

! In areas where temperatures can be below -10°C in the winter time, it is necessary to install a pre-heating device.

! In all PassiveHouse applications the pre-heater is mandatory.

Summer condensation

In very humid zones in the summer time there could be condensation on the supply side when indoor air is cooled therefore we supply an additional drain connector in order to install if needed (see pictures below).

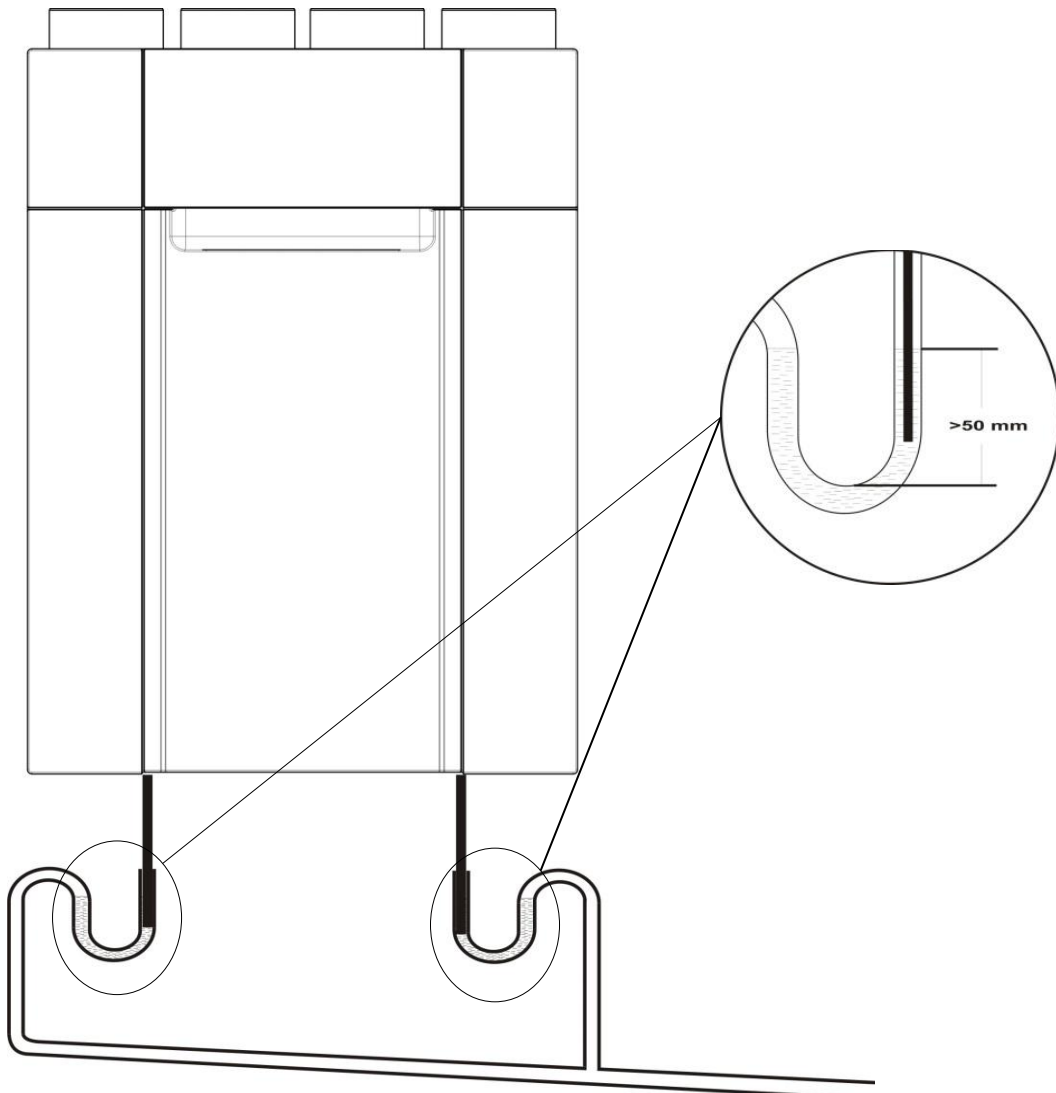
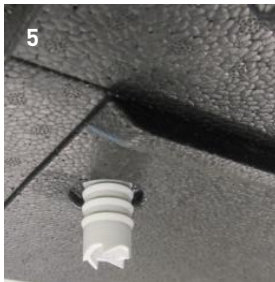
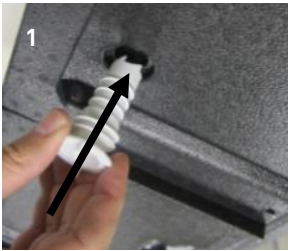

4. CHARACTERISTICS AND ELECTRICAL CONNECTIONS

4.1. ELECTRICAL CONNECTION

The unit is supplied with power cable and schuko plug.

Power supply: 230V AC, 50Hz
 Max. current: 0,8A
 Max. power: 90W
 Maximum ambient temperature: 50°C
 Maximum flow temperature: 45°C

- **Power electrical connection and remote control**

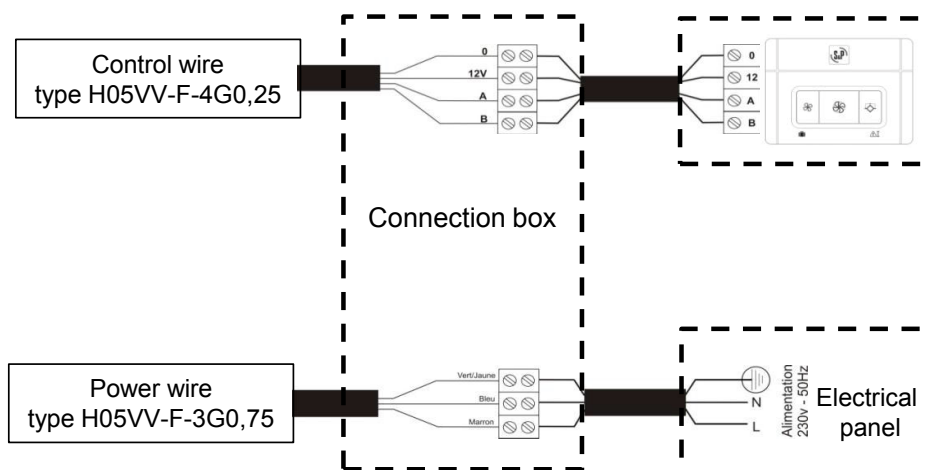

50 m to connect with the remote control.

- **MODBUS network**

Use shielded cable and twisted-pair type **PAR-POS 2x2x0,34**.

- **Free voltage contact connection**

Pass the cable through the interior of ferrite type **WE 742 727 33 MnZn** twice.



- **Installation of cable glands**



Installation of cable glands

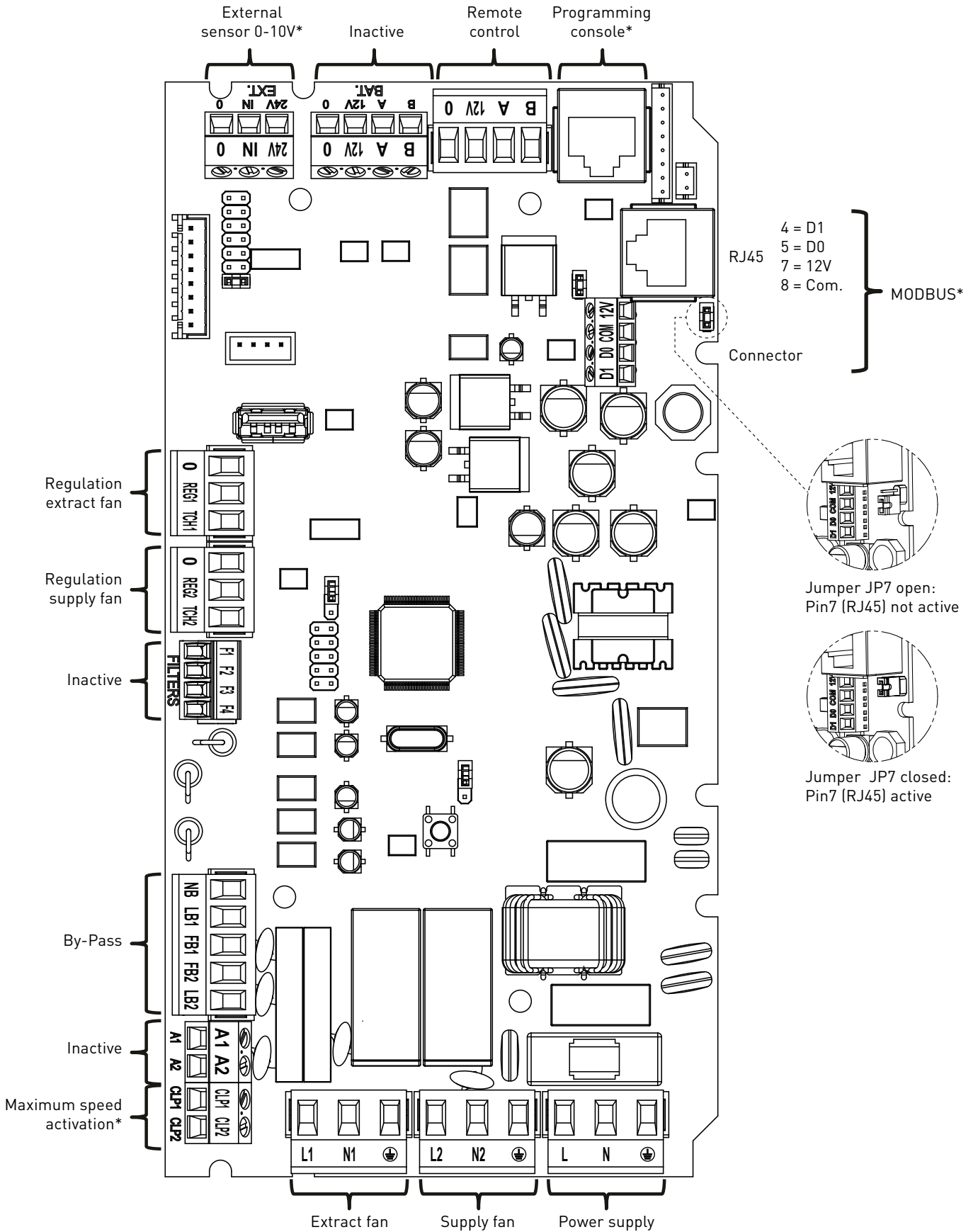

* Not provided

4.2. SPCM-WB COMMUNICATIONS MODULE CONNECTION FOR IOT CONNECTAIR CONNECTION (OPTIONAL)

Note: The SPCM communication module is not compatible with the use of the remote controller included with the DOME0 unit.

To connect the SPCM-WB communications module to the unit, please follow the following instructions:

- First, disconnect the unit from the power.
- Disconnect the remote control from the main board.
- Fix the SPCM-WB in the hole located in the upper left hand corner, above the main board. This is done by inserting a screw into the EPP body of the DOME0 unit through a clip on the module (see drawing 1).
- Once fixed, connect the SPCM-WB with the cable supplied to the central board in the Modbus terminal block. (see drawing 2).
- Finally, change position of Jumper J1 from open to closed (see drawing 3).
- The installed set will be as per image 4.

This allows the unit to be controlled through the CONNECTAIR platform rather than the remote control, which improves the functionality of the unit.

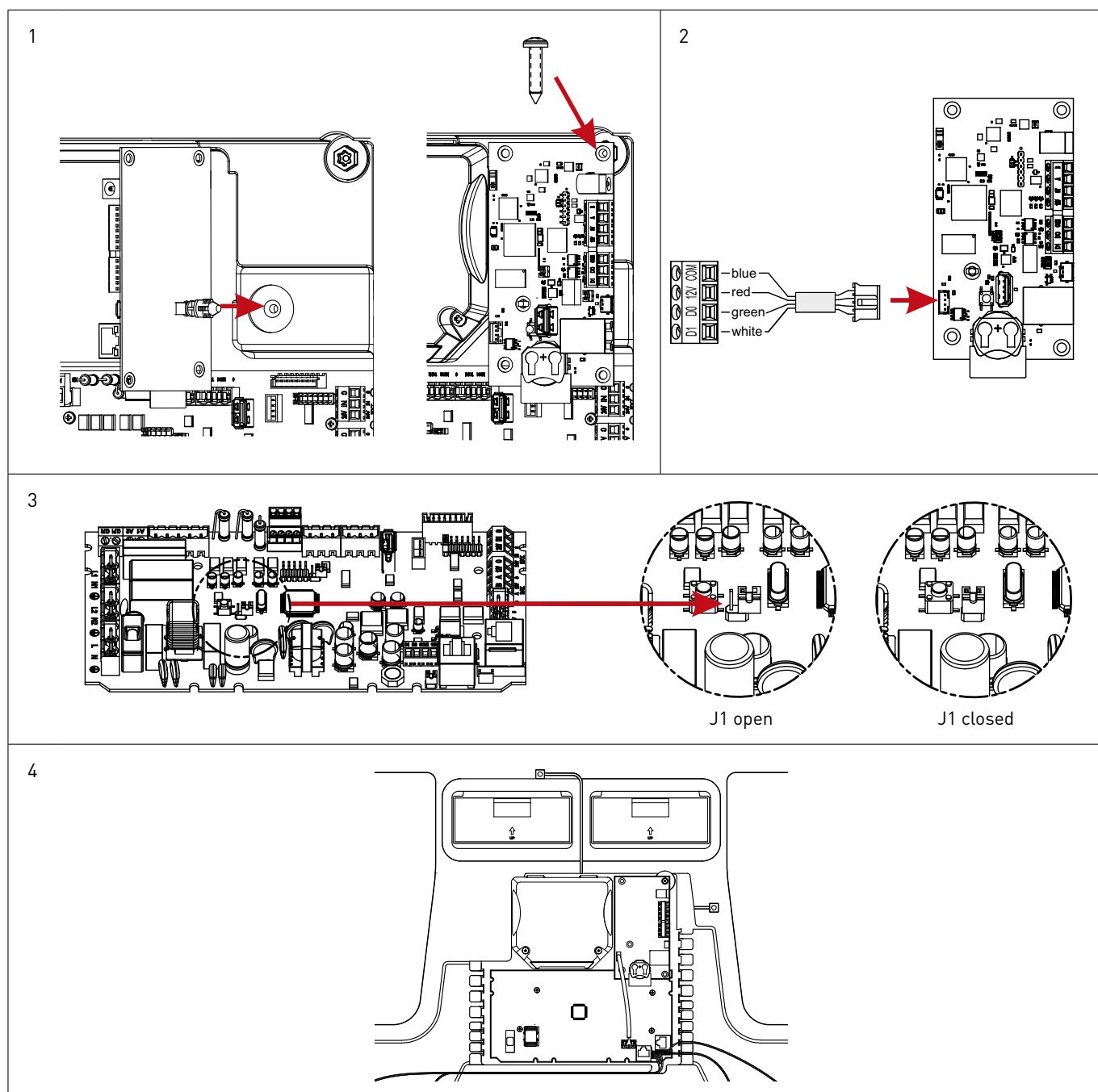

5. COMMISSIONING OF THE DOMEO

5.1. FOR INSTALLATION:

The remote control allows:

- Adjust the airflows (1st speed, 2nd speed, 3rd speed)
- Timer for adjusting the filter maintenance period (6, 9, 12 or 15 months) (factory setting 12 months)
- Adjust the balance of supply / extraction airflows

5.1.a Airflow adjustment

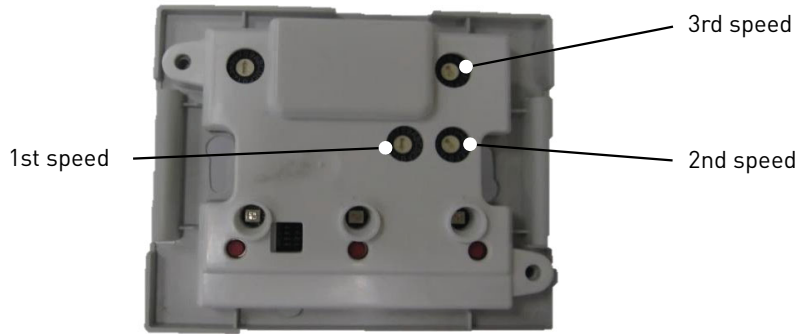

To adjust the airflow turn the potentiometer carefully clock wise with a small screw driver.

Factory setting: 1st speed = position 3; 2nd speed = position 5; 3rd speed = position 7
 (The curves below are showing the airflow according to the position of the potentiometer)

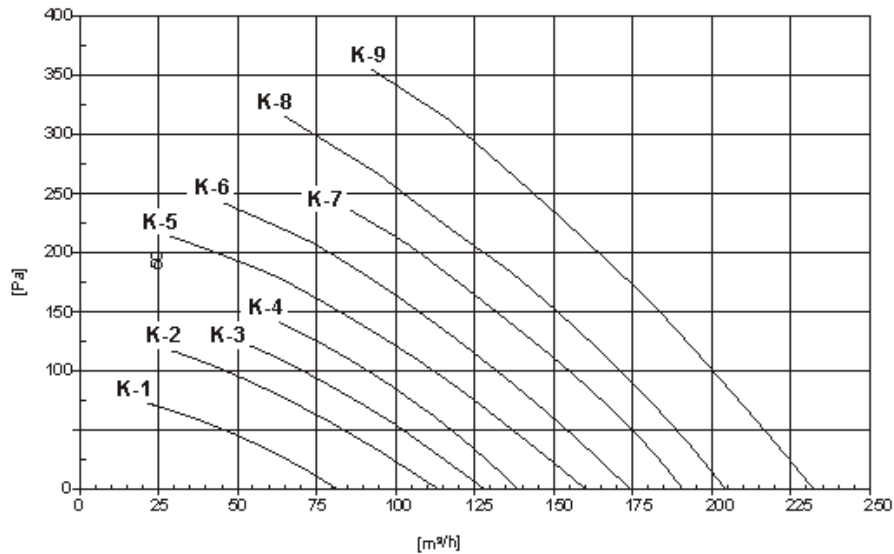

5.1.b Adjustment of the filter maintenance period

It is possible to set maintenance period to 6, 9, 12 or 15 months (12 months factory setting). The filter clogging depends on the pollution of the area where the unit is installed. We recommend checking the time in which the filter clogs and adjusting this period. It is advisable to do this after the second filter change as the first filter life maybe reduced due to construction dust and humidity in the system.

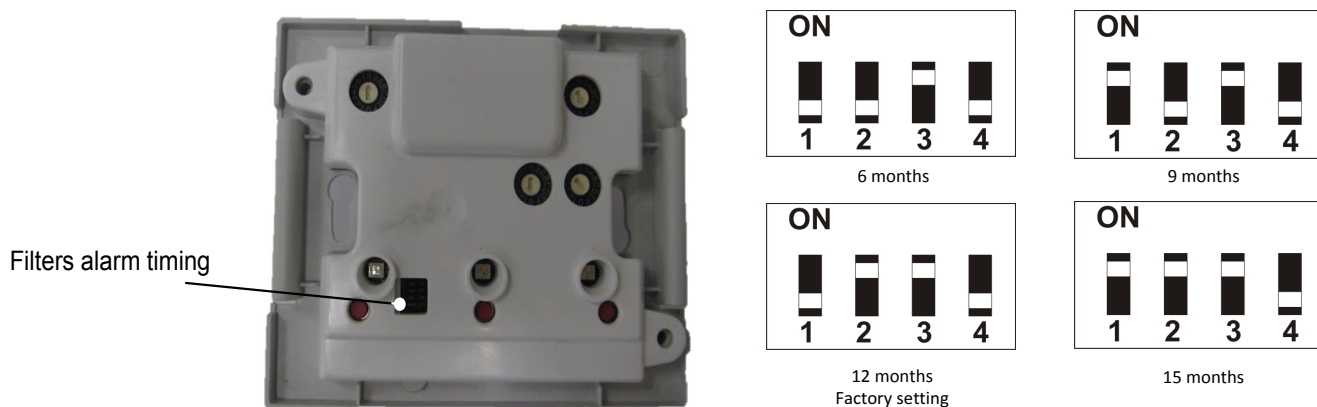

5.1.c Supply/extraction airflow adjustment

In the case that in the building is a chimney, gas oven or any apparatus which needs combustion air and there is no additional supply air opening for this, it is necessary to adjust the unit in the way that the combustion is not affected. It is necessary to add a supplementary air supply equal to the extract airflow due to the natural draught of the chimney.

After finishing the installation it is recommended to use this feature to balance the airflows!

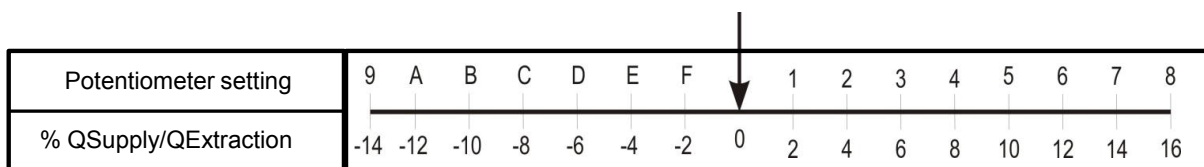
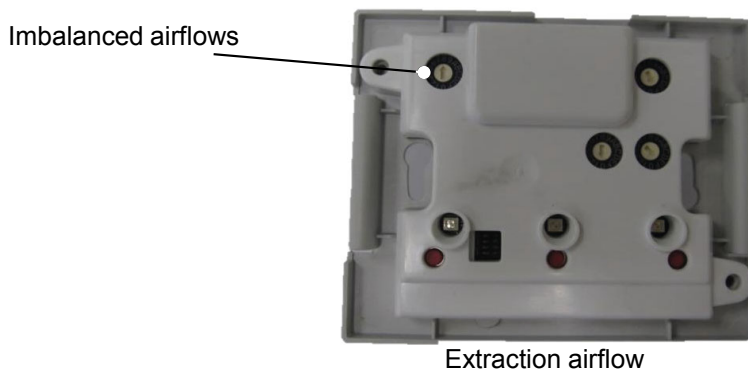

Example:

- Minimum calculated airflow = 90 m³/h
- Supply airflow necessary = 99 m³/h
→ Potentiometer position 5 = +10%



The adjustment is made on the supply airflow compared with extraction airflow.

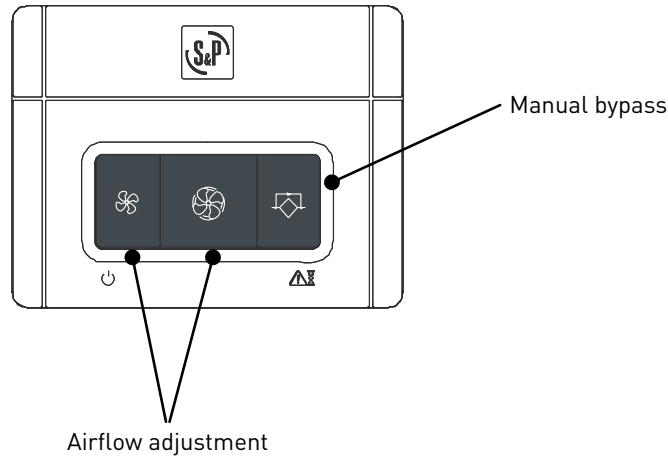

6. REMOTE CONTROL ADJUSTMENTS - USER



Speed adjustment

Pressing the "airflow adjustment" buttons you can change the speed  and . The LED will be green illuminated (see pictures below).

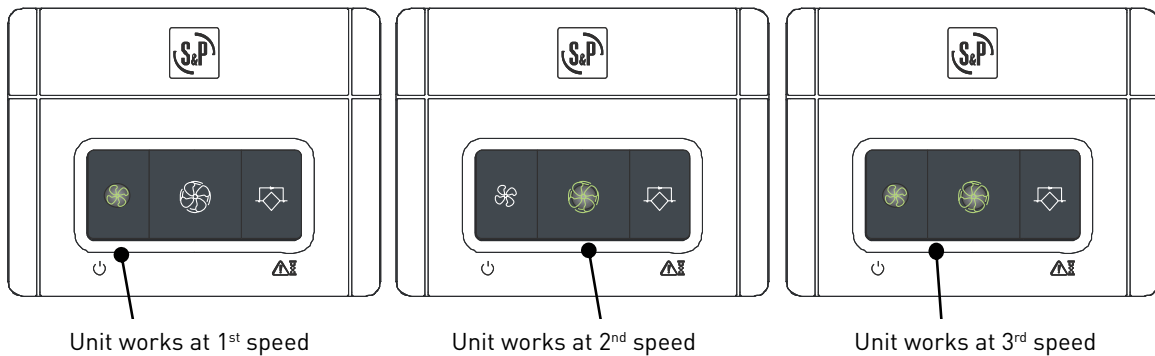

Automatic bypass

The DOME0 works with a pre-programmed automatic bypass. The following conditions have to be fulfilled to open/close the bypass.

T_{int} = indoor temperature
 T_{ext} = outdoor temperature

Activation conditions: $[(T_{int} - T_{ext} > 1) \text{ and } (T_{int} > 23) \text{ and } (T_{ext} > 13)]$
Deactivation conditions: $[(T_{int} - T_{ext} \leq 0) \text{ or } (T_{int} \leq 20) \text{ or } (T_{ext} \leq 10)]$

Manual bypass

Pressing the button "manual bypass" the bypass will open for 1 hour. During the bypass is activated the button is green illuminated. To deactivate (close) within the 8 hours the bypass you have to push the button again (illumination is off).

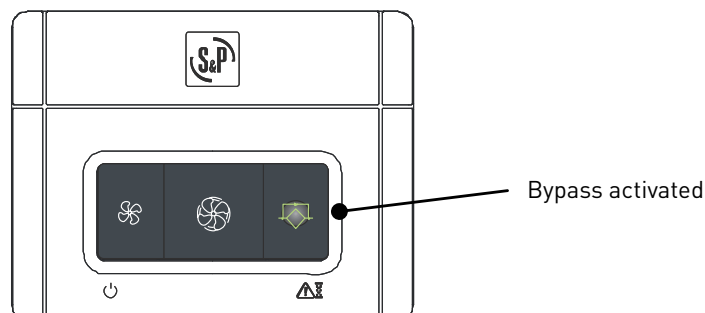

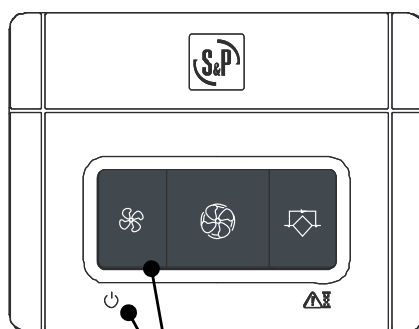

Standby function

Push and hold the button  for 3 seconds, the unit will switch into the standby mode (see drawing below). To switch the unit on push the button again.



Standby mode

Filter maintenance

When the button  is red illuminated, please check the filter as a maintenance is necessary. After the filter change press the  button during 3 seconds in order to reset the filter alarm.

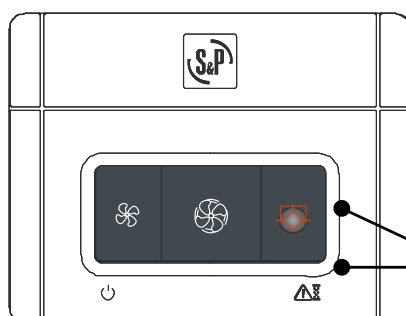

Filter maintenance



Stop mode (Flashing red LED):

Press the left key for 3 seconds to activate Stop mode. Press the key again to start up.



Filters alarm (red LED):

When the filters are dirty a red LED appears on the right hand key. The factory setting is 12 months after commissioning.

If this interval is not ideal for the configuration or use of your installation (filters too dirty or clean).

It is possible to adjust this setting from 6 to 15 months (in 3 monthly steps – see paragraph 5-1-b).

Once changes have been made push the button 3 seconds to deactivate the alarm and reset the timer.

7. SWITCHING ON THE DOME0

To start your DOME0 unit use the following process:

1. Verify that all system components are correctly installed and connected:

- Fresh air intake duct insulated and connected correctly (Do not use a fresh air intake equipped with insect screen)
- Fresh air and exhaust ducts insulated and connected correctly
- Fresh air and exhaust vents connected
- Flow regulators mounted in the right direction (if installed)
- Air outlet using insulated duct and connected to the outside (Using a roof cowl or outlet without an insect screen)
- Insulated flexible ducts taut and large radius bends (if installed)

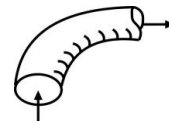
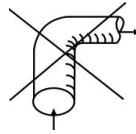

- Check that the unused spigots on plenums are sealed (if installed)
- Condensation drain well connected (siphon)
- Check that all connections are sealed (on the DOME0, on plenums and vents)
- Check the setting of the power circuit breaker

2. Turn on the DOME0

3. Adjust airflows.

8. ALARM INDEX

Through the LED located in the user control  it is possible to supervise the status of the unit. This LED will show the alarm (check see table) in case of produce the failure of some critical components of the unit or simply by notification (replacement filters, by-pas manual mode, supply temperature <5°C). Depending on risk level of the alarm generated, the control will manage the response required. If it is necessary, the unit will be stopped for safety reasons.

Priority	Alarm / State	LED	Action
1	Extract fan failure	Red LED, 1 blink	Unit stops
2	Supply fan failure	Red LED, 2 blinks	Unit stops
3	ByPass defect	Red LED, 3 blinks	Unit stops
4	Supply air temperature <5°C	Red LED, 4 blinks	Unit stops. Every 2 hours the unit starts for 5 minutes to ckeck if conditions allow normal operation
5	ODA sensor failure (fresh air)	Red LED, 5 blinks	Normal operation
6	SUP sensor failure (supply)	Red LED, 6 blinks	Normal operation
7	ETA sensor failure (extract)	Red LED, 7 blinks	Normal operation
8	EHA sensor failure (exhaust)	Red LED, 8 blinks	Normal operation
9	Dirty filter failure	Red LED continuous	Normal operation
10	ON bypass manual mode	Green LED continuous	Normal operation
11	Active defrost	Green LED blinking	Defrost management

Blink: A = 0,75s; Interval: B = 3s

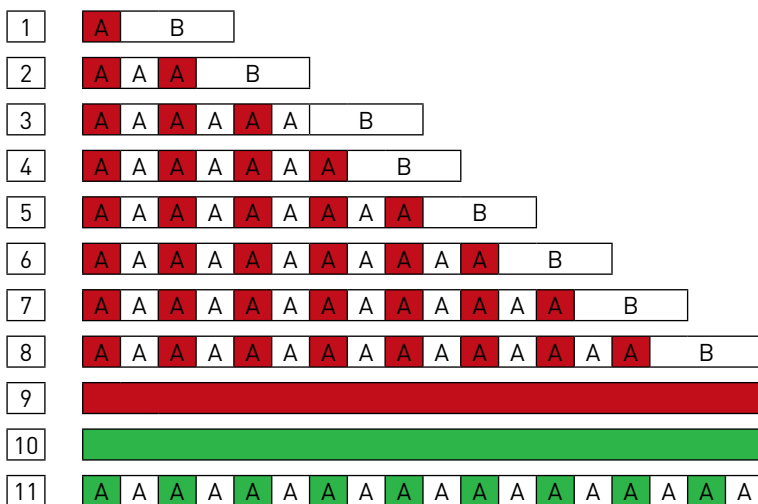

9. PRE-HEATER FOR PASSIVE HOUSE APPLICATION

In order to assure correct function of the unit and to comply with Passive house specification it is necessary to install a pre-heater on the unit.

We recommend following accessories:

- 1 pcs. Electric heater MBE-125/12B-R
- 1 pcs. Temperature probe TG-K
- 1 pcs. Pressure sensor DPS 2-30
- 1 pcs. TBI 30

Installation scheme

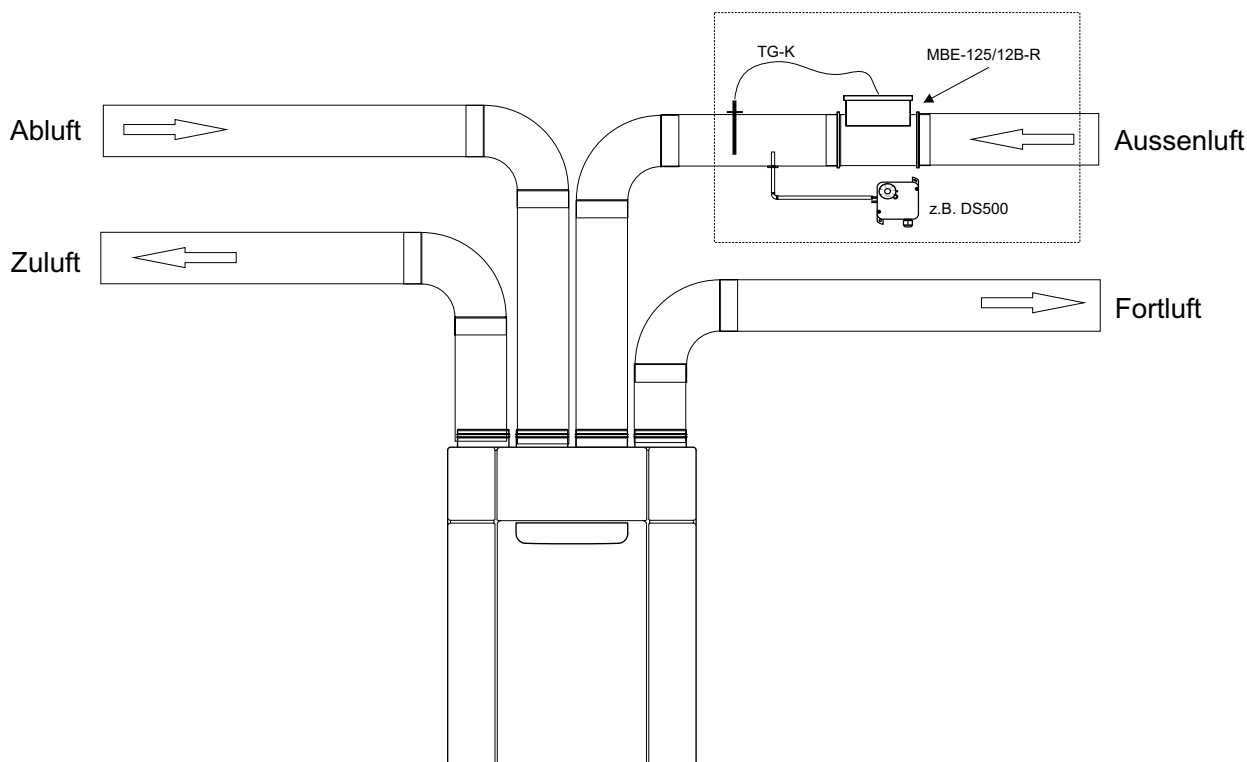

Technical data electric heater MBE-125/12B-R

Material: galvanised steel
 Power supply: 230V AC, 50Hz
 Power: 1200W
 Protection class: IP43

Detailed information, wiring diagrams, etc. you can find in the manual of the respective accessories.

10. PUTTING OUT OF SERVICE AND RECYCLING



EEC legislation and our consideration of future generations mean that we should always recycle materials where possible; please do not forget to deposit all packaging in the appropriate recycling bins. If your device is also labeled with this symbol, please take it to the nearest Waste Management Plant at the end of its servicable life.



S&P SISTEMAS DE VENTILACIÓN, S.L.U.

C. Llevant, 4
Polígono Industrial Llevant
08150 Parets del Vallès
Barcelona - España

Tel. +34 93 571 93 00
www.solerpalau.com



Ref. 9023060103-02