

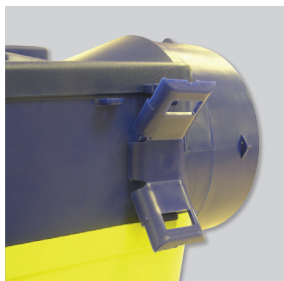

Auto-adjustable whole house extract group that ensures permanent renovation of air in single-dwellings. Conceived to run continuously, it guarantees the requirements established in the Technical Building Code. Equipped with centrifugal fan and 1-speed 230V-50Hz motor. The system should include airflow regulators or suitable auto-adjustable valves in the wet areas of the house (bathrooms and kitchen) and ECA air vents in the dry areas (living room, bedrooms), via which outside air will be introduced.

Characteristics

- 3 inlet valves of Ø80 mm for toilets and bathrooms, removable by means of a quarter turn and fitted with two ring clamps allowing a quick and watertight installation of the ducts without tools and clamps. The fourth inlet valve will be covered.
- Exhaust automatically regulated valves for kitchen of Ø125 mm.
- Discharge port of Ø125 mm allowing to expel the exhaust air to the outside.
- Terminal box fitted.
- Three plastic covers to block the exhaust valves that are not operating.
- Sleeve equipped with hooks that make easier the fastening of the extract duct.



Easy maintenance

3 opening and closing flanges allowing the dismantling of the assembly motor-extractor without the need of disconnecting the ducts and the exhaust valves.



Specific Applications



VMC
Single
dwelling



VMC
Multi
dwelling
blocks

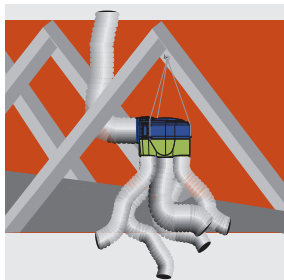

Remote location

Three ant vibration hanging cords enabling to hang the unit in the attic of a house or in false ceilings reducing the radiated noise.



Inlet valves for toilets and bathrooms

Removable by means of a quarter turn and fitted with two ring clamps allowing the fixing of the supply duct.

TECHNICAL CHARACTERISTICS

Model	Voltage (V)	Absorbed power at free discharge (W)	Absorbed current (A)	Sound power level Lw (dB(A))
VENTURIA E 2018	230	39	0,3	50

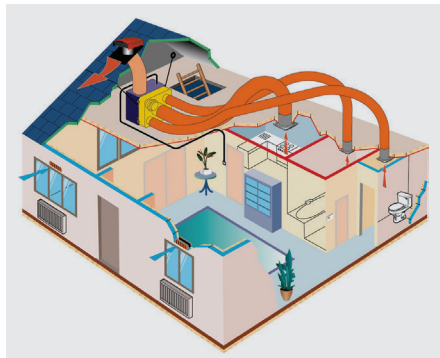

Continuous fresh air

The VENTURIA E 2018 extract system is conceived to run continuously, ensuring the permanent air renewal in residential houses.

DIMENSIONS (mm)

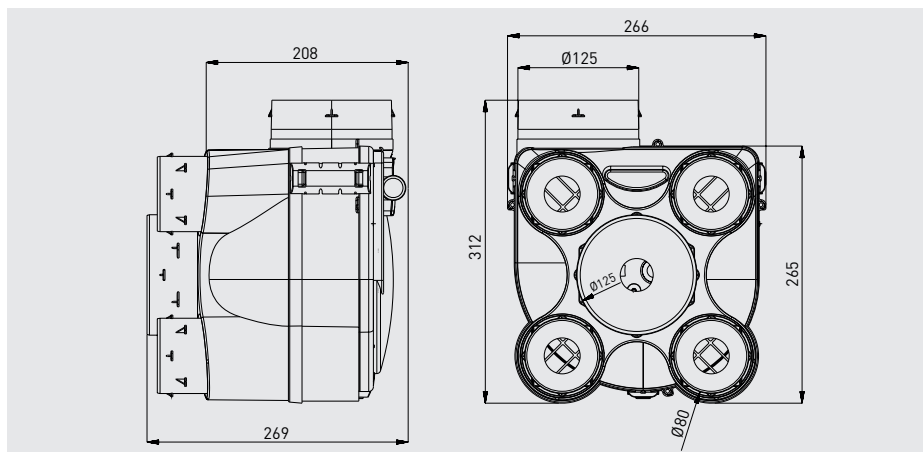

Curvas características

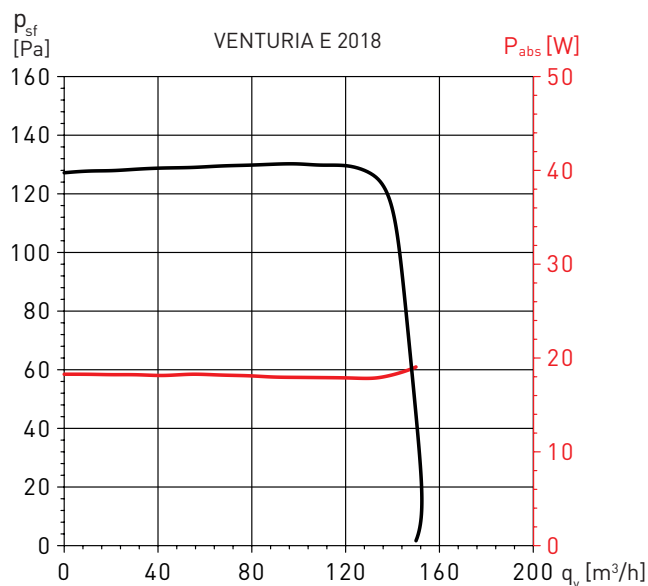

ACCESSORIES

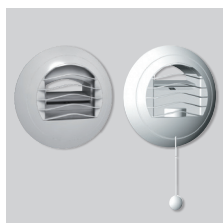

BAR ALIZE
Inlet valves.



EC-N ECA
Humidity adjustable air vents.



GP GPX GP-PRO GP-ISO
PVC ducts.

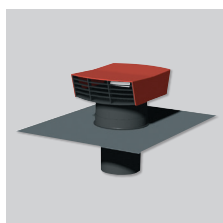

CT
Roof cap.



ADRF 100/80
Reduction to connect rigid duct.

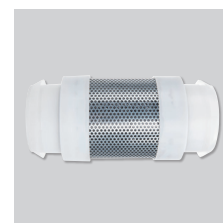

LA
Acoustic connections.