



# OZEO FLAT H ECOWATT





## 1. GENERAL

### 1.1. Warning

This equipment is designed for installation to provide controlled mechanical ventilation by extraction.

The manual aims to offer clear instructions and safety advice when preparing, installing and using the system.

As our products are constantly evolving, Soler & Palau reserves the right to make changes to the manual without prior notice.

### 1.2. General health and safety standards

This equipment has been designed to be incorporated into extraction ventilation system.

After the correct installation, the system will conform to EC directives and will pose no risks to health and safety or to the environment. This is also true for the other products used in the installation.

The following general guidelines are important:

Follow the safety instructions to prevent damage to the motorised fans or people.

The technical specifications in this manual should not be altered.

The motorised fans should not be changed.

The motorised fans must have a single-phase alternating current electrical power supply of 230 V/50 Hz.

To make sure the installation complies with EC directives, OZEO FLAT must be connected to the electrical grid according to current standards.

The device must be mounted in such a way so that, under normal operating conditions, there is no risk of contact with moving or electrical parts.

The OZEO FLAT system meets current standards for electrical appliances.

Before servicing the device, make sure the power is off.

Make sure to use appropriate tools.

Use the device only for its designated purpose.

This appliance can be used by children aged from 8 years and above and persons with reduced physical, sensory or mental capabilities or lack of experience and knowledge if they have been given supervision or instruction concerning use of the appliance in a safe way and understand the hazards involved. Children shall not play with the appliance. Cleaning and user maintenance shall not be made by children without supervision. (7.12, EN 60335-1.)

### 1.3. Warranty and public liability

#### Warranty

The equipment comes with a 2 year warranty from the date of purchase. This warranty includes free delivery of spare parts.

#### The warranty does not cover:

Assembly and dismantling costs.

Any defects that Soler & Palau considers are due to improper installation or use, or due to neglect or an accident.

The defects that appear after being used or repaired by a third party not approved by Soler & Palau.

To return a defective part, the user should contact the installer.

#### Liability

Ozeo Flat H is designed for ventilation systems, to provide a mechanical extract and fresh air supply for individual housing. Soler & Palau cannot be held responsible for damage caused by:

- Misuse,
- Normal wear and tear,
- Failure to follow the instructions in the manual regarding safety, use and implementation,
- Using parts not supplied by Soler & Palau.

## 2. EXTRACTION GROUP CHARACTERISTICS

### 2.1. CONFIGURATION

The equipment has:

#### Extract spigots

- 1 central spigot of diameter 125 mm for ventilation of the kitchen.
- 4 spigots of diameter 80 mm for other damp rooms: toilet, shower room, bathroom, en suite
- These 5 spigots have double row of grips to improve and facilitate the connection of flexible ducting.

#### Discharge spigot

- 1 spigot of diameter 125/160mm to connect to the discharge grille.

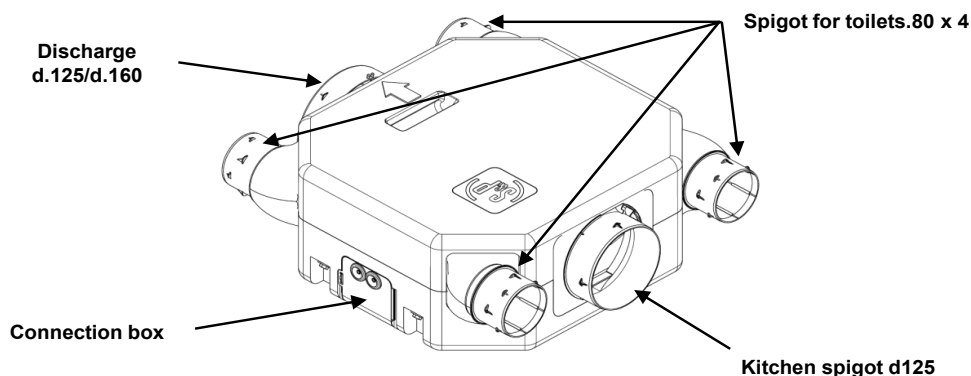

### 2.3. DIMENSIONS AND WEIGHT

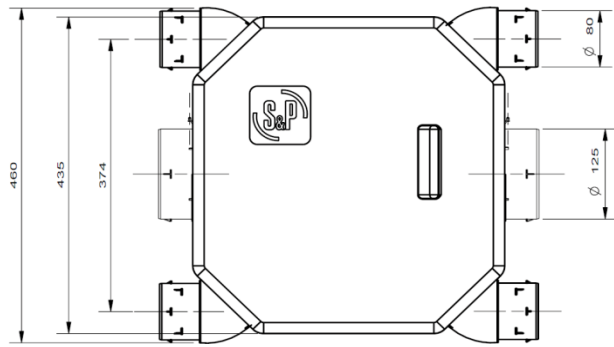
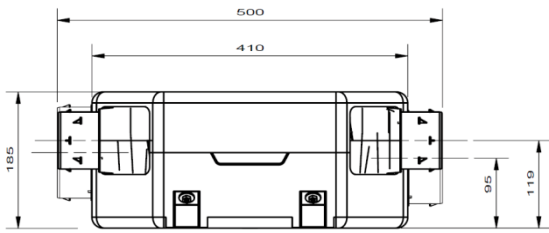

**WEIGHT:** 3 kilos

**Total dimensions:** 500 mm x 460 mm x 185 mm

### 3. INSTALLATION

The OZEO FLAT H series is specially designed for installation behind false ceilings, but it can be installed on any wall, either horizontal, vertical or at an angle.

#### 3.1. FIXING

The equipment has a support to facilitate mounting.

1. Use the support to mark the drill points.
2. Fix the support to the wall/ ceiling.

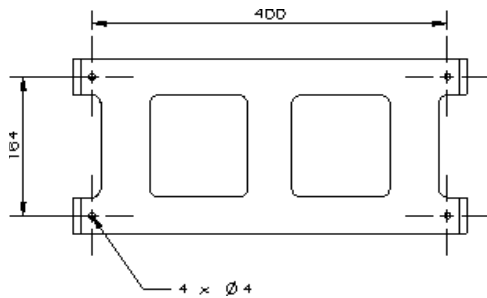

3. Support the fan in the support guides and fix the screws to secure the unit to the support.

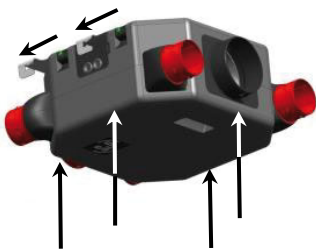

#### 3.2. CONNECTING DUCTWORK

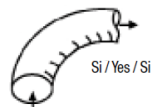
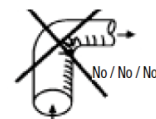
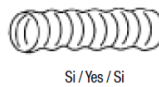
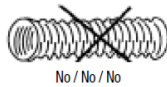

For ease of assembly, disengage the spigot from the unit, fix the duct to the spigot with flanges and refit the spigot to the unit. Those spigots not used must be covered with the covers supplied.

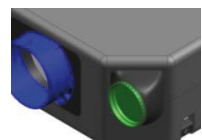



Accessory for duct of  $\varnothing 100$ : place the accessory in the spigot and fix it with the clamp.



### 90° Spigot rotation

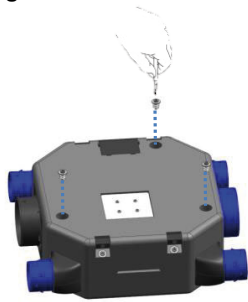

1

Remove the 3 screws TORX T40 (with hexagonal head 10 mm) in the cover



2

Open equipment



3

Turn the spigots



4

Close and do not forget to screw the lid back into position

### 3.3. ELECTRICAL CONNECTION

Power supply: 230V – 50Hz  
 Maximum current: 0.3 A  
 Electrical protection: 2 A  
 Maximum power: 38 W

Depending on installation pressure drop, to adjust working pressure via potentiometer (40-220 Pa)

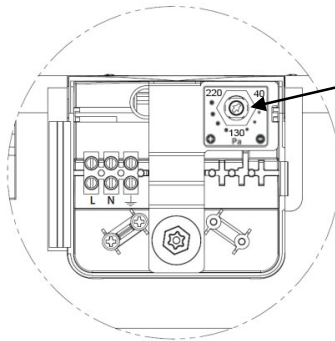

Pressure adjustment potentiometer



### 4. MAINTENANCE

**Attention:** Before any handling, switch off the power supply to the device.

**Every 6 months:** With a damp cloth clean both the inlets from the rooms and the extraction grilles from the wet rooms.

**Every 2 years:** Open the unit and remove the dust from the inside with a dry brush.

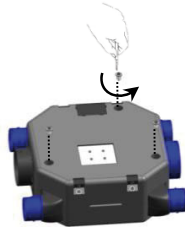

3 \* TORX T40

(with hexagonal head 10 mm)



### 5. WASTE MANAGEMENT

Product according to RAEE.

EU regulations and our commitment to future generations oblige us to recycle used materials; please remember to dispose of all superfluous packaging materials at the appropriate recycling points, and to drop off obsolete equipment at the nearest waste management point.

For any questions regarding S&P products, contact one of our After Sales offices (Spain only) or your dealer (rest of world). To find your nearest S&P dealer, visit our website at [www.solerpalau.com](http://www.solerpalau.com).

Ref. 9023064703

